

# INDUSTRIAL SUPPLY TOOLS CATALOGUE

English | Catalogue no. 18

A Company of the SWAROVSKI Group  
[www.tyrolit.com](http://www.tyrolit.com)

**TYROLIT**

# Editorial

## Dear customers and readers,

In your hands you are holding the latest edition of the TYROLIT specialist industry catalogue (no. 18), containing a comprehensive overview of the products currently available from the TYROLIT portable tool range. For many of you this catalogue is another valuable addition to your toolkit, giving you a detailed look at the qualities of our products. It may also serve as a source of inspiration for new and exciting business areas into which you could expand in future.

In this catalogue you will find all our product innovations from the last two years. I would like to draw your attention in particular to our extensive "Cerabond" range of ceramic tools, as well as numerous interesting developments in the fields of coated abrasives and brushes.

Another common theme you will notice throughout many chapters is health and the environment. Our new "Deep-Cut Protection", for example, ensures significantly enhanced user safety in cutting applications. And the recently developed "Comfort Start" enables the user to work safely with rough grinding wheels right from the very start. There is one thing above all else that is important to us: the health of our users. It is therefore not surprising that we have been using an increasing number of natural fibres in the last two years, both for some flap discs and for purely natural fibre discs. These represent an interesting alternative to normal fibre discs.

As well as developing new products using innovative materials, we never lose sight of our core expertise in

grinding and cutting. In this chapter you will find all our current top products in the "Next generation" section. Regardless of what you use it for, a TYROLIT product is definitely the right choice.

When leafing through the catalogue you will also see that this year we have put considerable thought into user friendliness. The current catalogue includes various new chapters and cross references to make working life that little bit easier.

We hope you enjoy reading our new catalogue.

Best wishes,  
Your TYROLIT Team



## Four steps to the right product

### 1. Select the application

e.g. cutting, grinding, etc.

### 2. Select the machine

e.g. angle grinder, straight grinder, etc.



### 3. Performance level

We offer 3 different performance levels: Premium, Standard and Basic



### 4. Which material is being machined?

Each performance level is further subdivided into different materials, such as stainless steel, steel, etc.

Items with grey lettering are only available on request.

## Other search options

**Product finder** P.382ff

**Index pages** P.389ff



# TYROLIT Group

## A global company

As one of the world's leading manufacturers of bonded grinding, cutting, sawing, drilling and dressing tools and a system supplier of tools and machines for the construction industry, the family-run TYROLIT company has been synonymous with superior quality, innovative spirit and outstanding service since 1919.

Day in, day out the experts at TYROLIT are busy working on solutions that accommodate the individual requirements of customers around the world; thus contributing to their business success. Some 80,000 available products set the standard in various industrial sectors.



## Business units

TYROLIT offers its customers cost-efficient and "green" solutions in four business units. Moreover, with its global sales network and a team of experienced application engineers, TYROLIT provides top-quality service.



### Trade

Thanks to its global sales network, in addition to premium product solutions in the three core areas of cutting, grinding and finishing, TYROLIT's Trade business unit guarantees truly customer-focused marketing support.



### Construction

In the Construction business unit TYROLIT is a leading system supplier of sophisticated drilling systems, wall and wire saws, floor saws and for grinding uneven surfaces such as motorways made of concrete.

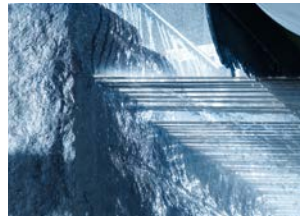

### Stone – Ceramics – Glass

Our customised diamond tools and grinding solutions in the Stone – Ceramics – Glass business unit cannot fail to impress through their exceptional performance and quality.



### Metal / Precision

From precision machining in the engine and gear industry to the production of cut-off wheels with diameters up to 2,000 mm for the steel industry – the TYROLIT product range in the Metal & Precision business unit includes high-tech tools for a huge variety of applications.

## Quality and Innovation

TYROLIT is one of the world's market leaders in this sector. For us, maximum precision is paramount – both in the quality of the manufactured products and where innovation is concerned. Continuous further development and improvement of products in all business units is one of our primary corporate objectives.

## Expertise for our customers

TYROLIT offers its customers a first-class service in the form of ongoing advice and support. In each of our business units a team of specialists with years of experience in the industry assists and supports our customers worldwide with individual on-site expertise.

## Customised products

TYROLIT has a huge and varied product range for numerous fields of application. These include both standard products for everyday use and individually adapted, made-to-order products for customer-specific processes. Together with our customers, we find the most cost-effective solution for the task with which we are entrusted.

# International production and sales locations

TYROLIT is represented in 29 countries through its own production and sales companies and cooperates in a further 65 countries with local partners.

Everyday our several hundred field service colleagues are working hard in the market alongside our end customers, in order to be able to provide them with advice and support whenever they need it. Of course, with these countless visits we constantly witness new challenges for application technology, which we view as opportunities for new products.



**Sales companies** in Argentina, Australia, Austria, Belgium, Brazil, Canada, China, Czech Republic, Denmark, Estonia, Finland, France, Germany, Hungary, India, Indonesia, Italy, Netherlands, Norway, Poland, Portugal, South Africa, Spain, Sweden, Switzerland, Thailand, UK, UAE and the USA.

**Distributors** in more than 65 countries across the globe

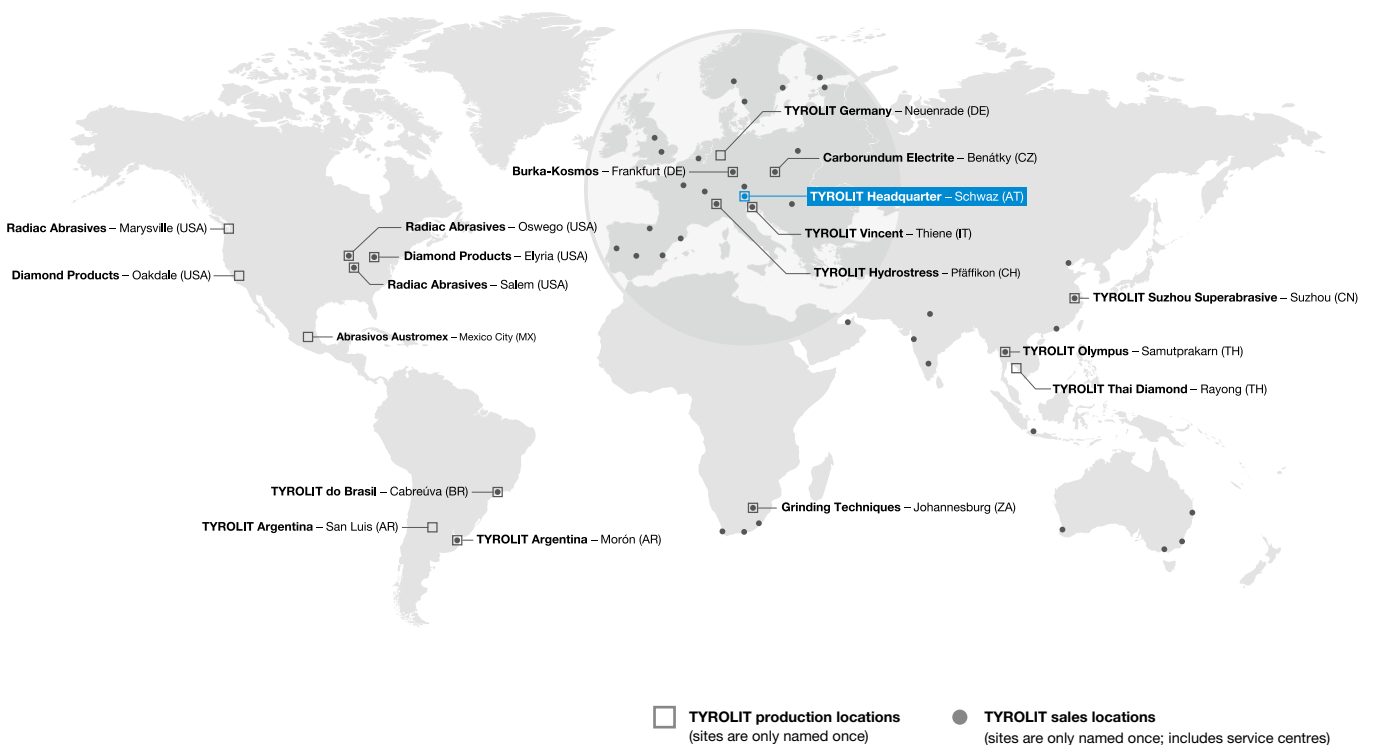



### Global focus

TYROLIT believes in thinking and acting globally. With a worldwide sales network currently in 65 countries and with production plants in 12 countries, we offer our customers all the advantages of a globally active company.



### Local availability

Think globally, act locally – in your local language and right on your premises. This is the principle we follow as we grow hand-in-hand with our customers. Local contacts and technical distribution in numerous countries guarantee you the best possible customer support.



### Customer service

A coordinated supply chain – from production to delivery – guarantees on-time delivery for customers. Moreover, the use of modern planning systems and a team of specialised customer service employees ensures orders are processed quickly and smoothly.



### Global logistics

With 10 warehouses around the world, we ensure the best possible product availability for customers 365 days a year.

#### TYROLIT warehouses

- |             |                  |
|-------------|------------------|
| — Argentina | — Czech Republic |
| — Brazil    | — Great Britain  |
| — France    | — USA            |
| — Spain     | — Austria        |
| — Thailand  | — South Africa   |

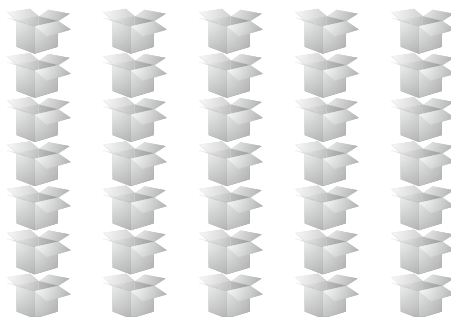

**3.300.000**

consignments leave the Benatky site every year.

**7.700.000**

consignments leave the Schwaz site every year.



## From a good idea to an excellent product

### What happens at TYROLIT when we get a good idea for a new product?

First of all, our product management team gets to grips with it. We have to find out precisely what is involved. Once our product managers have analysed all aspects and consider them to be good enough, a well-established process is initiated in which they take a leading role.



Of course, we do not leave our product managers to deal with this mammoth task on their own. To assist them, there are no fewer than 100 colleagues on hand in Research & Development. From fundamental research in the chemistry lab to questions pertaining to physics, whether theoretical or in the form of actual tests in the workshop, our employees in this department are constantly looking for new solutions.

Thus there are over 400 different abrasive types and combinations available to our product managers, which we can integrate in several hundred different bond systems.

From this unimaginable wealth of possibilities, the first test wheels are then produced. We prefer to try out many variations so that we can work on a solution in a truly comprehensive way.

Then testing begins. Not only is the work result tested, but also whether the relevant solution can later be produced in larger quantities. We test whether the prospective products can be produced to a consistently high level of quality, as well as important aspects such as imbalance, lateral load and bursting speed values, to ensure we produce products for our customers that not only demonstrate high quality, but are also safe.

And finally it comes to the material. But not just any material. Here too we are very precise, in order to achieve reliable and above all comparable results. Every test material therefore needs a test certificate.

Once comprehensive testing both off-hand and also with stationary machines has been completed, and the best abrasive grain and bond system have been found, we can start with production.

It is not enough for us to simply start well with a new product, we want to guarantee a consistently high level of quality. We owe that to our name and to our customers. For this reason, we continue to take and test samples from every production batch in order to guarantee our high quality standards.

Ultimately it is our most important promise to our customers that we can regularly offer new and excellent innovations at the highest quality level, because that is what the name TYROLIT represents.

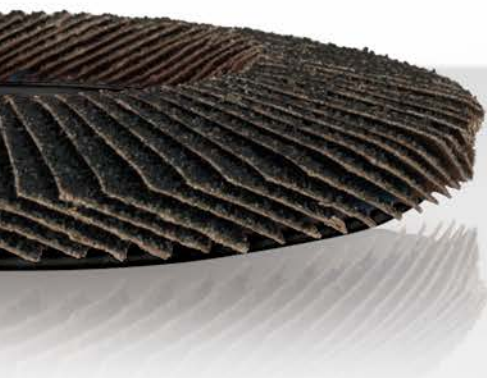

# Quality lines

TYROLIT has been one of the leading manufacturers of tools for every professional and application for almost 100 years.

To make your search for the ideal tool easier, we have divided our range into three performance levels. This enables us to offer the perfect solution for every application!



## PREMIUM★★★

- Maximum cutting ability and stock removal rate
- Above-average lifetime
- The best work results
- Maximum economic efficiency
- Extensive product range - the perfect product for every application
- Use of the most innovative technology and the best raw materials
- Maximum comfort for the user thanks to low vibration and noise levels

## STANDARD★★

- Excellent cutting ability and stock removal rate
- Excellent service life
- Exceptional work results
- High level of economic efficiency
- Large product range - for the most important applications

## BASIC★

- Good cutting ability and stock removal rate
- Good service life
- Good work results



# Symbols

## SAFETY



Wear gloves



Wear a mask



Only permitted for wet grinding



Not permitted for side grinding



Wear eye protection



Wear protective clothing



Not permitted for wet grinding



Off-hand and hand-guided grinding not permitted



Wear ear protection



Observe the instructions



Do not use damaged wheels



Free from Fe, S, Cl

## MATERIAL



Steel



2in1 steel/stainless steel



High-speed steel



Universal



Abrasive materials



2in1 aluminium/stone



Rails



All in One



Asphalt



3in1 cast iron/steel/stainless steel



Tiles



Stainless steel



2in1 aluminium/stainless steel



Carbide metal



Concrete



Paint/lacquer



Gel coat



Plastic



Marble



Wood



Cast iron



Stone



Titanium



Hard stone



Composites



Nonferrous metals

## MACHINES



Dry core drill



Angle grinder with brush



Pneumatic angle grinder



Stationary cutting machine



Wet core drill



Angle grinder



Petrol cutting saw



Table saw



Belt grinder



Joint cutter



Mini belt grinder



Burnishing machine



Floorstand grinder



Dual action sander



Hand-guided grinding



Angle grinder with cup wheel



Portable belt grinder



Straight grinder





## **CUTTING**

---

Cutting information  
Angle grinders  
Straight grinders

Petrol cutting saws  
Stationary cutting machines

## **GRINDING**

---

Grinding information  
Angle grinders  
Straight grinders

## **BRUSHES**

---

Brushes information  
Angle grinder  
Straight grinder

Floorstanding grinder  
Hand-guided grinding

## **COATED ABRASIVES**

---

Grinding information  
Angle grinder  
Straight grinder  
Belt grinder

Hand sanding and super finishing  
Dual action sander  
Burnishing machine  
Floorstanding grinder

## **DIAMOND TOOLS**

---

Grinding information  
Angle grinder  
Petrol cutting saw  
Floor saw

Table saws  
Core drilling  
TYROLIT machines

## **NOTES**

---

Safety  
Quick product search  
General

## **SYMBOLS**

---

Safety  
Material  
Machines





# CATALOGUE 18

## CUTTING

<b>Cutting information</b>	<b>14</b>
Explanation of labels	14
Specification	15
Machine pictograms	15
<b>Angle grinders</b>	<b>17</b>
1.1 Cut-off wheels	18
Accessories	35
<b>Straight grinders</b>	<b>37</b>
1.2 Cut-off wheels	38
Accessories	40
<b>Petrol cutting saws</b>	<b>41</b>
1.3 Cut-off wheels	42
<b>Stationary cutting machines</b>	<b>49</b>
1.4 Stationary cut-off wheels	50
Non-reinforced stationary cut-off wheels	57

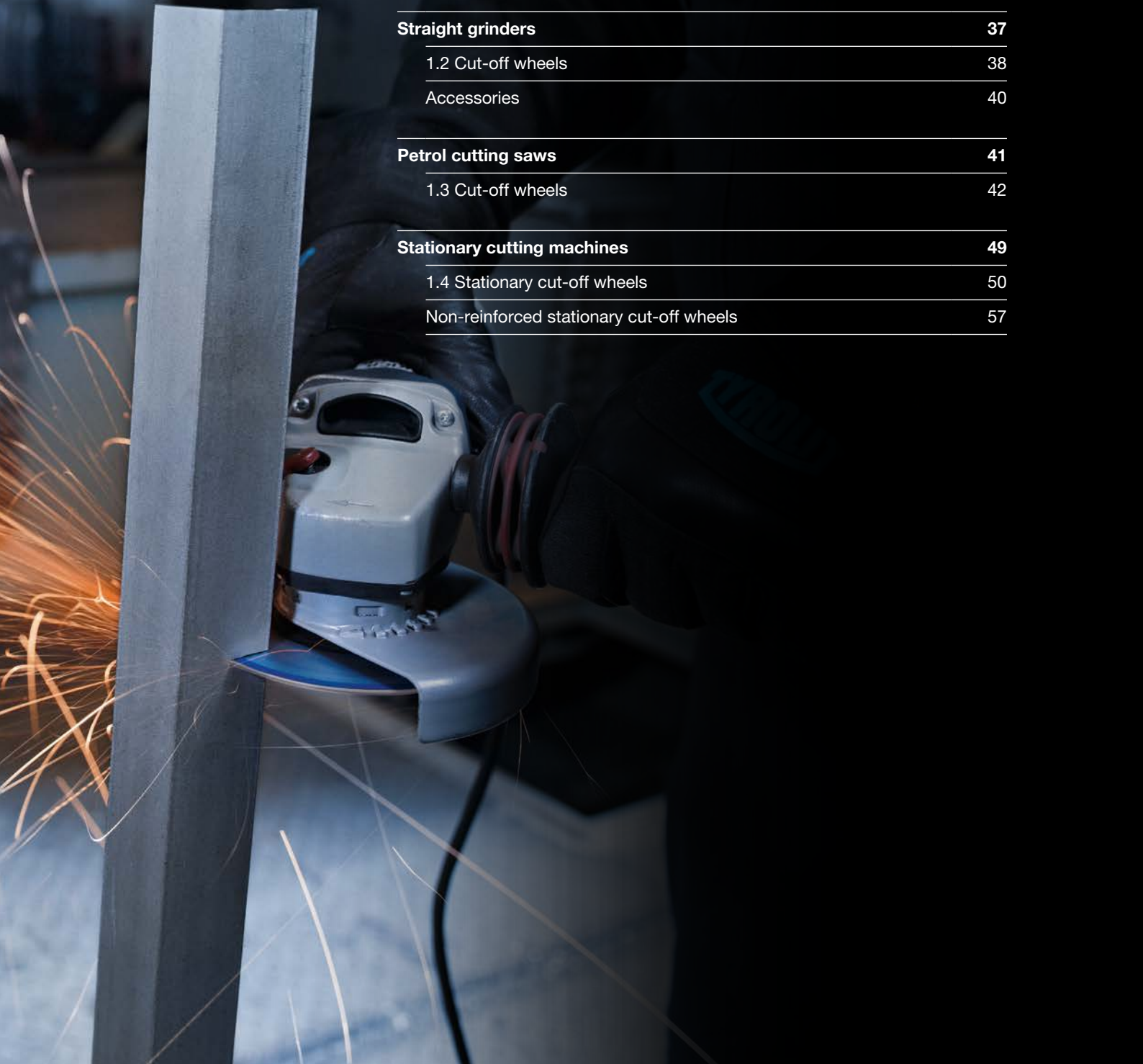

# SPECIFIC INFORMATION

## RESIN-BONDED CUT-OFF WHEELS

### Cut-off wheels product label



### Colour codes

<b>Label</b>	Steel	2in1/3in1	INOX	Nonferrous metals	Cast iron	Stone
<b>Colour code</b>	Blue	Blue	Red	Orange	Purple	Green
<b>Material</b>	Steel	2in1 = Steel and stainless steel, 3in1 = Steel, stainless steel and cast iron	Stainless steel	Aluminium, copper, zinc, brass, bronze, stone	Cast materials	Stone

## Cut-off wheels specification

### A46S-BFXA

<b>A</b>	External reinforcement: with external reinforcement
<b>X</b>	TYROLIT internal designation
<b>F</b>	Fibre-reinforced: Fibre glass (safety, lateral load, operating speed)
<b>B</b>	Bonding agent: B = Resin
<b>S</b>	Designation of hardness: N, O, P, Q, R, S, T
<b>46</b>	Grit size 30 in mesh: usually 24, 30, 36, 46, 60, 80, 120
<b>A</b>	Abrasive: A ... Regular aluminium oxide, C ... Silicon carbide, ZA ... Zirconia alumina, CA ... Ceramic

## Pictograms for machines



Angle grinder



Straight grinder



Petrol cutting saw



Stationary cutting machines







# 1.1 ANGLE GRINDER CUT-OFF WHEELS







## CUT-OFF WHEELS FOR ANGLE GRINDERS

Working with an angle grinder is one of the most important processes in the handicraft and industrial sectors for machining all types of metals. TYROLIT offers the ideal cut-off wheels for convenient and quick use with small and large angle grinders.

The benefits of our cut-off wheels in terms of innovation and economy can be clearly seen when it comes to cutting thin metal sheets and profiles. Our PREMIUM products in particular offer you the ultimate performance and lifetime, very clean cutting areas and low thermal load. This means there is only a limited amount of

rework required, saving you time and money.

However, the highest priority here at TYROLIT is the health of our customers. TYROLIT cut-off wheels therefore meet the highest safety standards and contribute significantly to improving your working conditions. Reduced

vibration and noise considerably improve your level of comfort while working.

On the following pages you will find the perfect tool for your requirements thanks to the uniform colour code for all materials.

# Shapes

 **41** Cut-off wheels  
(straight design)

 **42** Cut-off wheel  
(depressed-centre design)



 **27 EC und 27CC**  
CUT and GRIND  
(depressed-centre design)



## Application recommendation



performance level	Specification	Page	Steel	Stainless steel	2in1	NF metals	Cast iron	NF metals/stone	
<b>PREMIUM</b> ★★★	A60R-BFKA	23		●					
	A46R-BFKA	22,23		●					
	A30R-BFKA	29		●					
	A60R-BFXA	22,23			●				
	A46R-BFXA	23			●				
	A30R-BFXA	28,29			●				
	A60S-BFKA	LONGLIFE 21	21	●					
	A46S-BFKA	LONGLIFE 21	21	●					
	A46S-BFXA	LONGLIFE 21	21	●					
	A30S-BFXA	LONGLIFE 27	27	●					
	TA60P-BFXA	2in1 22,26	22,26			●			
	A60Q-BFKA	2in1 22	22			●			
	A46Q-BFKA	2in1 22	22			●			
	A30Q-BFKA	2in1 28	28			●			
	A46Q-BFXA	2in1 30	30			●			
	A30Q-BFXA	2in1 28,31	28,31			●			
	CA60Q-BFKA	2in1 26,27	26,27			●			
	CA46Q-BFKA	2in1 26,27	26,27			●			
	A60N-BFXA	24	24				●		
	A46N-BFXA	24	24				●		
	A30N-BFXA	29	29				●		
	ZA30R-BFXA	30	30					●	
	ZA30P-BFXA	30	30					●	
	DC CI	30	30					●	
	C46S-BFXA	26	26						●

Items with grey lettering are only available on request.

Performance level	Specification	Page			
			Steel	Stainless steel	Stone
<b>STANDARD**</b>	A60R-BFINOX	32		•	
	A46R-BFINOX	32		•	
	A30R-BFINOX	32		•	
	A30S-BF	31	•		
	C30S-BF	32, 33			•

Performance level	Specification	Page			
			Stainless steel	2in1	Stone
<b>BASIC*</b>	A60R-BFINOX	34	•		
	A60Q-BF	2in1 33		•	
	A46Q-BF	2in1 33, 34		•	
	A30Q-BF	2in1 33, 34		•	
	C30S-BF	35			•

Items with grey lettering are only available on request.

# PREMIUM\*\*\* CUT-OFF WHEELS

## SUPER-THIN LONGLIFE CUT-OFF WHEELS FOR STEEL

**+ Enhanced economic efficiency**  
 Significant increase in lifetime and cutting ability, which is particularly evident in their first-cut performance. The wheel delivers the best results with shorter cutting times right from the very first cut.

**+ Reduced working times**  
 A low load on the workpiece and short cutting times allow you to quickly achieve the best result. No supplementary reworking, such as cleaning or deburring.



**+ Maximum comfort while working**  
 The tool operates consistently and without a jamming tendency, producing 30% less cutting dust. Additional sound and vibration damping are features that make the super-thin TYROLIT cut-off wheels a safe and convenient tool.

**TYROLIT Film**



The product film can be found on YouTube at [www.youtube.com/TYROLITgroup](https://www.youtube.com/TYROLITgroup)



The next generation of TYROLIT PREMIUM\*\*\* cut-off wheels achieves a better performance than other PREMIUM wheels, and with considerably reduced tool wear. In

thicknesses of 1.0 to 1.6 mm, these super-thin cut-off wheels are suitable for all types of steel and impress with exceptional results without compromise.

As well as a clear improvement in productivity, these cut-off wheels also promote environmentally friendly use thanks to reduced waste production.

**PREMIUM\*\*\* CUT-OFF WHEELS**  
 Super-thin LONGLIFE cut-off wheels for steel



	Shape	Type no.	Dimension	Specification	PU	
		41	16118	115x1.0x22.23	A60S-BFKA	25
		51825	115x1.6x22.23	A46S-BFKA	25	
		16121	125x1.0x22.23	A60S-BFKA	25	
		51838	125x1.6x22.23	A46S-BFKA	25	
		183114	178x1.6x22.23	A46S-BFXA	25	
		183113	230x1.9x22.23	A46S-BFXA	25	

Thicker cut-off wheels can be found from page 27.

**PREMIUM\*\*\* CUT-OFF WHEELS**

Super-thin 2in1 cut-off wheels for steel and stainless steel



With the next generation PREMIUM\*\*\* 2in1 cut-off wheels you can enhance performance while significantly reducing tool wear. In thicknesses of 1.0 to 1.6 mm, these super-thin 2in1 cut-off wheels have been developed for machining steel and stainless steel. The chemical purity makes this tool ideal for machining stainless steel. In

this way, impairments to the material, such as corrosion, pitting corrosion or a reduction in the fatigue strength, can be avoided. As well as a clear improvement in productivity, these cut-off wheels also promote environmentally friendly use thanks to reduced waste production.

	Shape	Type no.	Dimension	Specification	PU		
		41	773268	115x1.0x22.23	A60Q-BFKA	25	
			384142	115x1.2x22.23	TA60P-BFXA	25	
			14082	115x1.6x22.23	A60Q-BFKA	25	
			773269	125x1.0x22.23	A60Q-BFKA	25	
			384143	125x1.2x22.23	TA60P-BFXA	25	
			14085	125x1.6x22.23	A46Q-BFKA	25	
			401205	150x1.2x22.23	TA60P-BFXA	25	
			34165055	150x1.2x22.23	A46Q-BFKA	25	
			920351	150x1.6x22.23	A46Q-BFXA	25	
			34165056	178x1.6x22.23	A46Q-BFKA	25	
			920353	230x1.9x22.23	A46Q-BFXA	25	
				34040608	115x1.0x22.23	A60Q-BFKA	10 Tin
				34040609	125x1.0x22.23	A60Q-BFKA	10 Tin
				42	87215	115x1.0x22.23	A60Q-BFXA
		87216		125x1.0x22.23	A60Q-BFXA	25	

Thicker cut-off wheels can be found from page 28.

**PREMIUM\*\*\* CUT-OFF WHEELS**





Super-thin cut-off wheels for stainless steel



With the next generation PREMIUM\*\*\* cut-off wheels for stainless steel you can enhance performance while significantly reducing tool wear. Super-thin cut-off wheels can be obtained from TYROLIT in thicknesses from 0.75 to 1.6 mm. They are particularly suitable for thin-walled metal sheets, profiles and pipes, as well as reinforced steel. Even for small stainless steel cross-sections and rods, and corrosion-

resistant or acid-resistant stainless steel these cut-off wheels offer effortless machining. The chemical purity of this tool is a requirement of machining stainless steel in order to avoid impairments to the material, such as corrosion, pitting corrosion or a reduction in the fatigue strength.

	Shape	Type no.	Dimension	Specification	PU	
		41	34040606	115x1,0x22,23	A60R-BFKA	10 Tin
			34040607	125x1,0x22,23	A60R-BFKA	10 Tin
			651998	100x1,0x16	A60R-BFXA	25
			610935	115x0,75x22,23	A60R-BFXA	25
			674471	115x1,0x22,23	A60R-BFKA	25
			51841	115x1,6x22,23	A46R-BFKA	25

	Shape	Type no.	Dimension	Specification	PU	
		41	610937	125x0,75x22,23	A60R-BFXA	25
			674473	125x1,0x22,23	A60R-BFKA	25
			51844	125x1,6x22,23	A46R-BFKA	25
			34060382	150x1,2x22,23	A46R-BFKA	25
			291583	150x1,6x22,23	A46R-BFXA	25
			34059901	178x1,6x22,23	A46R-BFKA	25
				42	282149	115x0,75x22,23
	282150			125x0,75x22,23	A60R-BFXA	25
	291587			150x1,6x22,23	A46R-BFXA	25
	291588			178x1,6x22,23	A46R-BFXA	25

Thicker cut-off wheels can be found from page 28.

# PREMIUM\*\*\* CUT-OFF WHEELS

## SUPER-THIN CUT-OFF WHEELS FOR NONFERROUS METALS

+ **Enhanced economic efficiency**  
Significant increase in lifetime and cutting ability, which is particularly evident in their first-cut performance. The wheel delivers the best results with shorter cutting times right from the very first cut.

+ **Reduced working times**  
Cutting times are reduced when used on aluminium, aluminium bronze, aluminium base alloys, copper, bronze, brass, nickel silver and titanium.



+ **Maximum comfort while working**  
The tool operates consistently and without a jamming tendency, producing 30% less cutting dust. Additional sound and vibration damping are features that make the super-thin TYROLIT cut-off wheels a safe and convenient tool.

The next generation of TYROLIT PREMIUM\*\*\* cut-off wheels achieves a better performance than other PREMIUM wheels, and with considerably reduced tool wear. In order to

cut nonferrous metals, the tool must have a high cutting ability. To this end, TYROLIT has developed a special formula and production method in order to achieve short cutting times

with NF metals too. New specifications prevent the clogging and dulling of the grinding wheel which used to be a common result of material abrasion.

**PREMIUM\*\*\* CUT-OFF WHEELS**

Super-thin cut-off wheels for nonferrous metals



The next generation of TYROLIT PREMIUM\*\*\* cut-off wheels achieves a better performance than other PREMIUM wheels, and with considerably reduced tool wear. In order to cut nonferrous metals, the tool must have a high cutting ability. To this end, TYROLIT has developed a special formula

and production method in order to achieve short cutting times with NF metals too. New specifications prevent the clogging and dulling of the grinding wheel which used to be a common result of material abrasion.

	Shape	Type no.	Dimension	Specification	PU	
		41	840247	115x1.0x22.23	A60N-BFXA	25
			170530	115x1.2x22.23	A46N-BFXA	25
			623553	115x1.6x22.23	A46N-BFXA	25
			257533	125x1.0x22.23	A60N-BFXA	25
			170542	125x1.2x22.23	A46N-BFXA	25
			739982	125x1.6x22.23	A46N-BFXA	25
			170567	150x1.2x22.23	A46N-BFXA	25
			42	170580	115x1.2x22.23	A46N-BFXA
170586	125x1.2x22.23			A46N-BFXA	25	
170587	150x1.2x22.23			A46N-BFXA	25	

Thicker cut-off wheels can be found from page 29.

**PREMIUM\*\*\* CUT-OFF WHEELS**  
**ACCU 2IN1 FOR STEEL AND STAINLESS STEEL**

+ **Cordless work**

Using this cut-off wheel you can work on smaller tasks in hard-to-reach application areas, benefiting from the usual Tyrolit quality but without requiring a power source.

+ **Universal application options**

With the PREMIUM\*\*\* ACCU you obtain a tool that can be used for a range of applications on steel and stainless steel.



+ **Reduced downtimes**

Thanks to the short-term and efficient application options, downtimes for the operator can be significantly reduced.





The super-thin PREMIUM\*\*\* cut-off wheel has been specially designed for battery-powered angle grinders and enables smaller repairs to be carried out without requiring a power source. This therefore makes it con-

siderably easier to use on scaffolding, in difficult-to-reach terrain or work-places. These products have been optimised for battery-powered angle grinders and are ideal for cutting thin-walled

metal sheets, profiles and pipes. They also make light work of machining small cross-sections, rods and reinforced steel.

**PREMIUM\*\*\* CUT-OFF WHEELS**  
 ACCU 2in1 for steel and stainless steel



	Shape	Type no.	Dimension	Specification	PU	PU
		41	34022958	115x1.0x22.23	A60Q-BFKA	25
			34022959	125x1.0x22.23	A60Q-BFKA	25

# PREMIUM\*\*\* CUT-OFF WHEELS

## 2IN1 WITH DEEP CUT PROTECTION FOR STEEL AND STAINLESS STEEL

**+ Enhanced safety**

The DEEP Cut protection metal bushing we have developed prevents the crown being removed from the wheel and thus a break out of the bore.

**+ Greater economic efficiency**

The longer range of application means that wheel changes are reduced.



**+ Versatile application options**

It is ideal for small sheet metal, profile and pipe cross-sections. Rods and metal reinforcements can also be cut effortlessly.

**TYROLIT Film**



The product film can be found on YouTube at [www.youtube.com/TYROLITgroup](http://www.youtube.com/TYROLITgroup)

Using newly developed technology and new materials we have succeeded in taking another step towards improved user safety. The PREMIUM\*\*\*

cut-off wheel with DEEP Cut Protection enables the user to achieve maximum insertion depths into the workpiece without damaging the wheel.

There is no risk of sharp workpiece edges removing the crown.



### PREMIUM★★★ CUT-OFF WHEELS

2in1 with DEEP Cut Protection for steel and stainless steel



Using newly developed technology and new materials we have succeeded in taking another step towards improved user safety. The PREMIUM★★★ cut-off wheel with DEEP Cut Protection enables the user to achieve maximum insertion depths into the workpiece without damaging the wheel.

There is no risk of sharp workpiece edges removing the crown.

	Shape	Type no.	Dimension	Specification	PU	
		42	34042238	115x1.2x22.23	TA60P-BFXA	25
			34042239	125x1.2x22.23	TA60P-BFXA	25
			34042240	150x1.2x22.23	TA60P-BFXA	25



### PREMIUM★★★ CUT-OFF WHEELS

For nonferrous metals and stone



This PREMIUM★★★ cut-off wheel reduces the work of the operator due to its excellent cutting ability. When used on tiles, ceramics, clinker and nonferrous metals, the wheel impresses by achieving clean cutting edges and excellent cutting quality. Machine wear is significantly reduced by low wheel thicknesses.

The advantages are topped off by its environmentally-friendly operation, thanks to the reduction in cutting waste.

	Shape	Type no.	Dimension	Specification	PU	
		41	337383	115x1.0x22.23	C46S-BFXA	25
			342978	125x1.0x22.23	C46S-BFXA	25
			320335	178x1.6x22.23	C46S-BFXA	25

Larger-diameter cut-off wheels can be found from page 45.



### PREMIUM★★★ CERABOND



2in1 for steel and stainless steel



The TYROLIT CERABOND system brings almost 100 years of experience to a new generation of highest performance tools. With the cut-off wheels from the CERABOND family, we have succeeded in achieving an optimal combination of specially treated ceramic grain and bond structure. Thus it is possible to retain the abrasiveness and the lifetime of the cut-off wheel at the highest level.

The unique bond system prevents premature grain break-out and guarantees the full grinding power of the individual grains.

	Shape	Type no.	Dimension	Specification	PU	
		41	34059903	115x1.3x22.23	CA60Q-BFK A	15
			34059904	125x1.3x22.23	CA60Q-BFK A	15
			34059905	150x1.3x22.23	CA60Q-BFK A	15
			34019872	115x1.6x22.23	CA46Q-BFKA	15
			34019880	125x1.6x22.23	CA46Q-BFKA	15



	Shape	Type no.	Dimension	Specification	PU	
		41	34019881	150x1.6x22.23	CA46Q-BFKA	15
			34059906	178x1.6x22.23	CA46Q-BFKA	15
			34059907	230x2.0x22.23	CA30Q-BFKA	15
		42	34059908	115x1.3x22.23	CA60Q-BFK A	15
			34059909	125x1.3x22.23	CA60Q-BFK A	15
			34059910	150x1.3x22.23	CA60Q-BFK A	15
			34019882	115x1.6x22.23	CA46Q-BFKA	15
			34019883	125x1.6x22.23	CA46Q-BFKA	15
			34019884	150x1.6x22.23	CA46Q-BFKA	15

**PREMIUM\*\*\* CUT-OFF WHEELS**  
 LONGLIFE for steel



In standard widths, this high-performance tool not only offers a cost-efficient solution, but also the highest safety standards. This is provided by the longest lifetime and stability of the PREMIUM\*\*\* LONGLIFE. The tool is suitable for cutting metal sheets, profiles, pipes, rods and solid material.

The assortment of LONGLIFE cut-off wheels ranges from 1.6 to 1.9 mm for quick and convenient operation with the longest lifetime, and from 2.5 to 3.0 mm for the longest lifetime and stability.

	Shape	Type no.	Dimension	Specification	PU	
		41	637066	115x2.0x22.23	A30S-BFXA	25
			637067	125x2.0x22.23	A30S-BFXA	25
			637068	150x2.0x22.23	A30S-BFXA	25
			785339	178x2.0x22.23	A30S-BFXA	25
			637069	178x2.5x22.23	A30S-BFXA	25
			785333	230x2.0x22.23	A30S-BFXA	25
			637070	230x2.5x22.23	A30S-BFXA	25
			42	637071	115x2.5x22.23	A30S-BFXA
			637072	125x2.5x22.23	A30S-BFXA	25
			637073	178x3.0x22.23	A30S-BFXA	25
			637074	230x3.0x22.23	A30S-BFXA	25

*Thinner cut-off wheels can be found from page 21.  
 Larger-diameter cut-off wheels can be found from page 44.*



**PREMIUM\*\*\* CUT-OFF WHEELS**

2in1 for steel and stainless steel



This high-performance tool has been designed to be used on both steel and stainless steel and its standard widths offer a cost-efficient solution. This is provided by the longest lifetime and stability of the PREMIUM\*\*\* 2in1. The tool is suitable for cutting metal sheets, profiles, pipes, rods and solid material.  
The assortment of 2in1 PREMIUM\*\*\* cut-off wheels ranges from 1.6 to

1.9 mm for quick and convenient operation with the longest lifetime, and from 2.5 to 3.0 mm for the longest lifetime and stability.

	Shape	Type no.	Dimension	Specification	PU		
		41	872338	115x2.5x22.23	A30Q-BFXA	25	
			872339	125x2.5x22.23	A30Q-BFXA	25	
			872340	150x2.5x22.23	A30Q-BFXA	25	
			872341	178x2.5x22.23	A30Q-BFXA	25	
			872342	178x3.0x22.23	A30Q-BFXA	25	
			34165057	230x2.0x22.23	A30Q-BFKA	25	
			872343	230x2.5x22.23	A30Q-BFXA	25	
			872344	230x3.0x22.23	A30Q-BFXA	25	
			42	872346	115x2.5x22.23	A30Q-BFXA	25
				912603	115x3.0x22.23	A30Q-BFXA	25
				872347	125x2.5x22.23	A30Q-BFXA	25
				872348	125x3.0x22.23	A30Q-BFXA	25
				907800	125x3.5x22.23	A30Q-BFXA	25
				872349	150x3.0x22.23	A30Q-BFXA	25
	872350		178x3.0x22.23	A30Q-BFXA	25		
	121878		230x2.5x22.23	A30Q-BFXA	25		
	872351		230x3.0x22.23	A30Q-BFXA	25		
	872352		230x3.5x22.23	A30Q-BFXA	25		

Thinner cut-off wheels can be found from page 22.



**PREMIUM\*\*\* CUT-OFF WHEELS**



For stainless steel



The chemical purity of this tool is a requirement of machining stainless steel in order to avoid impairments to the material, such as corrosion, pitting corrosion or a reduction in the fatigue strength. The tool is suitable for cutting metal sheets, profiles, pipes, rods and solid material.  
The assortment of these cut-off wheels ranges from 1.6 to 1.9 mm for

quick and convenient operation with the longest lifetime, and from 2.5 to 3.0 mm for the longest lifetime and stability.

	Shape	Type no.	Dimension	Specification	PU	
		41	41489	115x2.0x22.23	A30R-BFXA	25
			41491	115x2.5x22.23	A30R-BFXA	25
			41492	125x2.0x22.23	A30R-BFXA	25
			41493	125x2.5x22.23	A30R-BFXA	25

	Shape	Type no.	Dimension	Specification	PU		
		41	41494	125x3.0x22.23	A30R-BFXA	25	
		41495	150x2.0x22.23	A30R-BFXA	25		
		41499	178x2.0x22.23	A30R-BFXA	25		
		35946	178x2.5x22.23	A30R-BFXA	25		
		34059902	230x2.0x22.23	A30R-BFKA	25		
		35950	230x2.5x22.23	A30R-BFXA	25		
		41501	230x3.0x22.23	A30R-BFXA	25		
			42	35937	115x2.0x22.23	A30R-BFXA	25
			41504	115x2.5x22.23	A30R-BFXA	25	
			35944	125x2.0x22.23	A30R-BFXA	25	
			41505	125x2.5x22.23	A30R-BFXA	25	
			41506	125x3.0x22.23	A30R-BFXA	25	
			41507	150x2.0x22.23	A30R-BFXA	25	
			41508	150x3.0x22.23	A30R-BFXA	25	
41509	178x2.5x22.23		A30R-BFXA	25			
41510	178x3.0x22.23		A30R-BFXA	25			
41511	230x2.5x22.23		A30R-BFXA	25			
41513	230x3.5x22.23	A30R-BFXA	25				

Thinner cut-off wheels can be found from page 22.



**PREMIUM★★★ CUT-OFF WHEELS**

For nonferrous metals



In order to cut nonferrous metals, the tool must have a high cutting ability. To this end, TYROLIT has developed a special formula and production method in order to achieve short cutting times with NF metals too.

New specifications prevent the clogging and dulling of the grinding wheel which used to be a common result of material abrasion.

	Shape	Type no.	Dimension	Specification	PU		
		41	39624	115x2.5x22.23	A30N-BFXA	25	
		39321	125x2.5x22.23	A30N-BFXA	25		
		62726	150x2.5x22.23	A30N-BFXA	25		
		525355	178x2.0x22.23	A30N-BFXA	25		
		32141	178x2.5x22.23	A30N-BFXA	25		
		32142	230x2.5x22.23	A30N-BFXA	25		
			42	82646	115x2.5x22.23	A30N-BFXA	25
			366888	125x2.5x22.23	A30N-BFXA	25	
			468182	150x2.5x22.23	A30N-BFXA	25	
			5485	178x3.0x22.23	A30N-BFXA	25	
			651544	178x3.5x22.23	A30N-BFXA	25	
			30741	230x3.0x22.23	A30N-BFXA	25	

Thinner cut-off wheels can be found from page 24.

**PREMIUM\*\*\* CUT-OFF WHEELS**  
FOCUR Extra for cast iron



The PREMIUM\*\*\* FOCUR Extra cut-off wheel offers maximum abrasiveness coupled with the best cutting ability. Innovative production technology combined with high-quality zirconium aluminium oxide makes this possible. The assortment of these cut-off wheels ranges from 2.5

to 3.5 mm. This high-performance tool has been developed for use on all cast materials.

	Shape	Type no.	Dimension	Specification	PU	
		42	929885	115x2.5x22.23	ZA30R-BFXA	25
			929886	125x2.5x22.23	ZA30R-BFXA	25
			929887	178x3.5x22.23	ZA30R-BFXA	25
			929889	230x3.5x22.23	ZA30R-BFXA	25
			904019	178x3.5x22.23	ZA30P-BFXA*	25
			635268	230x3.0x22.23	ZA30P-BFXA*	25
			855818	230x3.5x22.23	ZA30P-BFXA*	25

\*Fe, S, Cl free

**FOCUR SA**  
Diamond cut-off wheel for grey and spheroidal cast iron



FOCUR SA diamond cut-off wheels from TYROLIT are the optimum tool for machining grey and spheroidal cast iron. These products combine a long lifetime with maximum economic efficiency. FOCUR SA cut-off wheels are available in diameters from 178 to 600 mm.

	Shape	Type no.	Dimension	Specification	PU	
		UC3	102811	180x3.0x22.23	DC CI	1
			102813	230x3.0x22.23	DC CI	1

**PREMIUM\*\*\* CUT AND GRIND**  
With DEEP Cut Protection for steel and stainless steel



With the introduction of the PREMIUM\*\*\* CUT AND GRIND it has become possible to perform applications such as grinding, deburring and shaping as well as cutting and plunging with only one tool. TYROLIT has now refined this technology. The wheels now have a thinner width of 2.0 mm and offer additional safety for the user with the new DEEP Cut Protection.

The risk of sharp workpiece edges removing the crown from the wheel and the consequent break out of the bore is prevented.



	Shape	Type no.	Dimension	Specification	PU	
		27EC	34042756	115x2.0x22.23	A46Q-BFXA	25
			34042757	125x2.0x22.23	A46Q-BFXA	25

**PREMIUM\*\*\* CUT AND GRIND**  
2in1 for steel and stainless steel



With the introduction of the PREMIUM\*\*\* CUT AND GRIND it has become possible to perform applications such as grinding, deburring and shaping as well as cutting and plunging with only one tool. The design of the wheel guarantees the highest performance right from the start without compromising on safety.

While it provides versatile application options, the CUT AND GRIND complies with the highest safety standards.



	Shape	Type no.	Dimension	Specification	PU
		27EC 743946	150x3.0x22.23	A30Q-BFXA	25
		743947	178x3.5x22.23	A30Q-BFXA	25

**STANDARD\*\* CUT-OFF WHEELS**  
For steel



This tool not only offers a cost-efficient solution for your everyday work, but also the safety standards customers have come to expect from Tyrolit. This is provided by the excellent lifetime and stability of the STANDARD\*\* cut-off wheel. The tool is particularly suitable for cutting solid material. This tool not only offers a cost-efficient solution for your everyday work,

This tool not only offers a cost-efficient solution for your everyday work, but also the safety standards customers have come to expect from Tyrolit. This is provided by the excellent lifetime and stability of the STANDARD\*\* cut-off wheel. The tool is particularly suitable for cutting solid material.

	Shape	Type no.	Dimension	Specification	PU
		41 368009	100x2.5x16	A30S-BF	25
		367565	115x2.5x22.23	A30S-BF	25
		367569	125x2.5x22.23	A30S-BF	25
		552399	125x3x22.23	A30S-BF	25
		367574	150x2.5x22.23	A30S-BF	25
		367578	178x3.0x22.23	A30S-BF	25
		367583	230x3.0x22.23	A30S-BF	25
		42 368010	100x2.5x16	A30S-BF	25
		367781	115x2.5x22.23	A30S-BF	25
		367785	115x3.0x22.23	A30S-BF	25
		367786	125x2.5x22.23	A30S-BF	25
		367789	125x3.0x22.23	A30S-BF	25
		367800	178x3.0x22.23	A30S-BF	25
		367803	230x3.0x22.23	A30S-BF	25

Larger-diameter cut-off wheels can be found from page 45.



**STANDARD\*\* CUT-OFF WHEELS**

For steel



This tool not only offers a cost-efficient solution for your everyday work, but also the safety standards customers have come to expect from Tyrolit. This is provided by the excellent lifetime and stability of the STANDARD\*\* cut-off wheel. The tool is particularly suitable for cutting solid material.

The assortment of STANDARD\*\* cut-off wheels for steel ranges from 2.5 to 3.0 mm. It offers a long lifetime and is suitable for universal use.

	Shape	Type no.	Dimension	Specification	PU	
		41	368016*	100x1.6x16	A46R-BFINOX	25
		367562*	115x1.0x22.23	A60R-BFINOX	25	
		367561*	115x1.6x22.23	A46R-BFINOX	25	
		367568*	125x1.0x22.23	A60R-BFINOX	25	
		408496	125x2x22.23	A30R-BFINOX	25	
		367567*	125x1.6x22.23	A46R-BFINOX	25	
		367776	150x2.0x22.23	A30R-BFINOX	25	
		367575	150x2.5x22.23	A30R-BFINOX	25	
		367576*	178x1.6x22.23	A46R-BFINOX	25	
		367777	178x2.0x22.23	A30R-BFINOX	25	
		367577	178x2.5x22.23	A30R-BFINOX	25	
		367581*	230x1.9x22.23	A46R-BFINOX	25	
		367780	230x2.0x22.23	A30R-BFINOX	25	
		367582	230x2.5x22.23	A30R-BFINOX	25	
			42	368017	100x2.0x16	A30R-BFINOX
367783	115x2.0x22.23			A30R-BFINOX	25	
367788	125x2.0x22.23			A30R-BFINOX	25	
367791	178x2.5x22.23			A30R-BFINOX	25	
367802	230x2.5x22.23			A30R-BFINOX	25	

\*Super-thin cut-off wheels

**STANDARD\*\* CUT-OFF WHEELS**

For stone



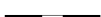

This STANDARD\*\* cut-off wheel reduces the work of the operator due to its excellent cutting ability. When used on stone materials, the wheel impresses by achieving clean cutting edges and good cutting quality.

Reworking is no longer required.

	Shape	Type no.	Dimension	Specification	PU	
		41	367566	115x2.5x22.23	C30S-BF	25
		367572	125x2.5x22.23	C30S-BF	25	
		367580	178x3.0x22.23	C30S-BF	25	
		367585	230x3.0x22.23	C30S-BF	25	



	Shape		Type no.	Dimension	Specification	PU
		42	368012	100x2.5x16	C30S-BF	25
			367782	115x2.5x22.23	C30S-BF	25
			367787	125x2.5x22.23	C30S-BF	25
			367801	178x3.0x22.23	C30S-BF	25
			367804	230x3.0x22.23	C30S-BF	25



Larger-diameter cut-off wheels can be found from page 46.

**BASIC★ CUT AND GRIND**  
2in1 for steel and stainless steel



The BASIC\* CUT AND GRIND makes it possible to perform applications, such as grinding, deburring and shaping as well as cutting and plunging, with only one tool. The design of the wheel guarantees good performance right from the start without compromising on safety.

While it provides versatile application options, the CUT AND GRIND complies with the highest safety standards



	Shape		Type no.	Dimension	Specification	PU
		27CC	743938	100x2.5x16	A30Q-BF	25
			743942	115x2.5x22.23	A30Q-BF	25
			757089	125x2.8x22.23	A30Q-BF	25
			743944	178x3.5x22.23	A30Q-BF	25

**BASIC★ CUT-OFF WHEELS**  
2in1 for steel and stainless steel



This tool is designed for use on both steel and stainless steel. Our BASIC\* cut-off wheel 2in1 has an excellent lifetime and stability. The tool is suitable for cutting metal sheets, profiles, pipes, rods and solid material. The 1.6 mm cut-off wheel available in the BASIC\* assortment is particularly

suitable for fast, convenient and low-burr work. The stable cut-off wheels in thicknesses between 2.0 and 3.0 mm have a very long lifetime and are suitable for universal use.

	Shape		Type no.	Dimension	Specification	PU
		41	222996	100x2.5x16	A30Q-BF	25
			34051373*	115x1.0x22.23	A60Q-BF	25
			222899*	115x1.6x22.23	A46Q-BF	25
			222997	115x2.5x22.23	A30Q-BF	25
			34051374*	125x1.0x22.23	A60Q-BF	25

\*Super-thin cut-off wheels

**BASIC★ CUT-OFF WHEELS**  
2in1 for steel and stainless steel



This tool is designed for use on both steel and stainless steel. Our BASIC\* cut-off wheel 2in1 has an excellent lifetime and stability. The tool is suitable for cutting metal sheets, profiles, pipes, rods and solid material. The 1.6 mm cut-off wheel available in the BASIC\* assortment is particularly

suitable for fast, convenient and low-burr work. The stable cut-off wheels in thicknesses between 2.0 and 3.0 mm have a very long lifetime and are suitable for universal use.

	Shape	Type no.	Dimension	Specification	PU		
		41	222900*	125x1.6x22.23	A46Q-BF	25	
		222998	125x2.5x22.23	A30Q-BF	25		
		34051375*	150x1.6x22.23	A46Q-BF	25		
		222999	150x2.5x22.23	A30Q-BF	25		
		633506*	178x1.6x22.23	A46Q-BF	25		
		250165	178x2.5x22.23	A30Q-BF	25		
		223000	178x3.0x22.23	A30Q-BF	25		
		633509*	230x1.9x22.23	A46Q-BF	25		
		291949	230x2.0x22.23	A30Q-BF	25		
		250169	230x2.5x22.23	A30Q-BF	25		
		223002	230x3.0x22.23	A30Q-BF	25		
			42	223020	100x2.5x16	A30Q-BF	25
				223021	115x2.5x22.23	A30Q-BF	25
				223022	125x2.5x22.23	A30Q-BF	25
291948	125x3.0x22.23			A30Q-BF	25		
223023	178x3.0x22.23			A30Q-BF	25		
222044	230x3.0x22.23			A30Q-BF	25		
291947	230x3.5x22.23			A30Q-BF	25		

\*Super-thin cut-off wheels

**BASIC★ CUT-OFF WHEELS**  
For stainless steel



The BASIC\* cut-off wheel for stainless steel can be used to cut metal sheets, profiles, pipes, rods with small diameters and solid material. The chemical purity of this tool is a requirement of machining stainless steel in order to avoid impairments to the material, such as corrosion, pitting corrosion or a reduction in the fatigue strength.

The 1.0 mm thick cut-off wheels are particularly suitable for quick, comfortable and low-burr cutting.

	Shape	Type no.	Dimension	Specification	PU	
		41	456491*	100x1.0x10	A60R-BFINOX	25
		222893*	100x1.0x16	A60R-BFINOX	25	
		222894*	115x1.0x22.23	A60R-BFINOX	25	
		222896*	125x1.0x22.23	A60R-BFINOX	25	

\*Super-thin cut-off wheels



**BASIC★ CUT-OFF WHEELS**

For stone



The BASIC\* cut-off wheel reduces the work of the operator due to its good cutting ability. When used on common building materials, the wheel impresses by achieving clean cutting edges and good cutting quality. The BASIC version of the 2.5 to 3.0 mm thick wheels offer a long lifetime and can be used for universal applications.

The advantages are topped off by its environmentally-friendly operation, thanks to the reduction in cutting waste.

	Shape	Type no.	Dimension	Specification	PU	
		41	223010	100x2.5x16	C30S-BF	25
			223012	115x2.5x22.23	C30S-BF	25
			223015	125x2.5x22.23	C30S-BF	25
			223016	150x2.5x22.23	C30S-BF	25
			222042	178x3.0x22.23	C30S-BF	25
			223019	230x3.0x22.23	C30S-BF	25
		42	223024	100x2.5x16	C30S-BF	25
			223025	115x2.5x22.23	C30S-BF	25
			223027	125x2.5x22.23	C30S-BF	25
			223029	178x3.0x22.23	C30S-BF	25
223031			230x3.0x22.23	C30S-BF	25	

Smaller-diameter cut-off wheels can be found from page 47.

**ACCESSORIES**

For cut-off wheels

Using these accessories you can significantly increase lateral stability. This means more precise cutting and enhanced first-cut performance are achieved. These special accessories are made of tempered tool steel and are suitable for angle grinders with an M14 drive screw. It is recommended for super-thin cut-off wheels in a straight design and a diameter of 178 and 230 mm in particular.

	Shape	Type no.	Dimension	PU
	100SFL	614644	76 mm	1





## **1.2 CUT-OFF WHEELS** FOR STRAIGHT GRINDERS





## CUT-OFF WHEELS FOR STRAIGHT GRINDERS

Straight grinders are always in high demand when precise results are required on difficult-to-access areas. Their versatile application options make straight grinders a popular tool.

In order to fulfil the high standards it sets for itself, TYROLIT has developed wheels for particularly quick low-burr cutting with maximum lifetimes. These high-performance tools are perfect for cutting metal sheets, profiles, pipes and rods even

in difficult-to access locations. For TYROLIT, the most stringent safety standards for our cut-off wheels - as with all of our products - are of the highest priority. Reduced vibration and noise considerably improve your level of comfort while working.

On the following pages you will find the perfect tool for your requirements thanks to the uniform colour code for all materials.

## Shapes

41 Cut-off wheels  
(straight design)

## Application recommendation



Performanceline	Specification	Pages	Steel	Stainless steel
<b>PREMIUM</b> ★★★	A100-BFM	40	●	
	A60R-BFXA	40		●
	A46R-BFXA	40		●

Items with grey lettering are only available on request.

**PREMIUM★★★ CUT-OFF WHEELS**

For steel



The quality of the PREMIUM\*\*\* cut-off wheel ensures the longest lifetime and cost-effective operation. By using the grit size 100, a particularly low burr result is achieved. The cut-off wheel in small diameters is designed for use on straight grinders.

This tool is suitable for cutting metal sheets, profiles, pipes, rods and solid material.

	Shape	Type no.	Dimension	Specification	PU
	41	699330	63x1.0x10	A100-BFM	100
		704198	63x2.0x10	A100-BFM	100
		325212	75x1.0x10	A100-BFM	100

**PREMIUM★★★ CUT-OFF WHEELS**

For stainless steel



The chemical purity of this tool is a requirement of machining stainless steel in order to avoid impairments to the material, such as corrosion, pitting corrosion or a reduction in the fatigue strength. The PREMIUM\*\*\* cut-off wheel in small diameters is designed for use on straight grinders.

This tool is suitable for cutting metal sheets, profiles, pipes, rods and solid material.

	Shape	Type no.	Dimension	Specification	PU
	41	323978	50x1.0x10	A60R-BFXA	100
		323970	50x2.0x6	A46R-BFXA	100
		299269	63x1.0x10	A60R-BFXA	100
		324404	63x1.6x10	A46R-BFXA	100
		711834	63x1.6x10	A60R-BFXA	100
		324402	63x2.0x6	A46R-BFXA	100
		324303	63x2.0x10	A46R-BFXA	100
		325228	75x1.0x8	A60R-BFXA	100
		299270	75x1.0x10	A60R-BFXA	100
		325222	75x1.6x10	A46R-BFXA	100
		331314	75x1.6x10	A60R-BFXA	100
		325224	75x2.0x8	A46R-BFXA	100
		325219	75x2.0x10	A46R-BFXA	100

**ACCESSORIES**

For cut-off wheels with a small diameter



These accessories enable cut-off wheels with small diameters to be clamped onto straight grinders. Easy handling and the highest possible

levels of safety are guaranteed for the operator. Please observe the maximum permissible speed.

	Shape	Type no.	Dimension	Specification	PU
		803404	S6/H10/M10	SS171	1
		846441	S10/H10/M10	SS173	1
		846442	S6/H6/M6	SS174	1



# 1.3 CUT-OFF WHEELS FOR PETROL CUTTING SAWS







## CUT-OFF WHEELS FOR PETROL CUTTING SAWS

Cutting materials on building sites with no electricity or limited infrastructure is a common challenge. Whether the material is reinforced steel, pipes or rails, a petrol-powered cut-off grinder provides a quick and efficient solution. Petrol cutting saws are particularly popular machines for cutting large cross-sections and are frequently used tools.

TYROLIT offers the perfect tools for these varied cutting tasks. Whether for use on steel, stainless steel, stone or rails, thanks to the clear colour coding and application tips, you will always be able to find the

right product for your application and the material to be cut. TYROLIT guarantees optimum cutting results and maximum levels of safety in all situations.

### Shapes

—  
41H Cut-off wheels  
(straight design)

# Application recommendation



Performance level	Specification	Page	Steel	Rails	Stone
<b>PREMIUM***</b>	A30O-BF02A2	44	●		
	A30P5BF71A2	44	●		
	A30Q-BF02A2	44	●		
	A30Q4BF71A2	44	●		
	M85A30P4BF91A2	44	●		
	A30N-BF02A2	44	●		
	MA30Q4BF97M2	44	●		
	A24Q-BF	44		●	
	A24Q-BF100	44		●	
	C24O-BF02A2	45			●
	C30P4BF71A2	45			●
	1C24R6BF38A2	45			●
	C247O4BF33A2	45			●



Performance level	Specification	Page	Steel	Rails	Stone
<b>STANDARD**</b>	A30S-BF	45	●		
	A30S-BF100	45	●		
	A30S-BF RAIL	46		●	
	A30S-BF RAIL100	46		●	
	C30S-BF	46			●
	C30S-BF100	46			●



Performance level	Specification	Page	Steel	Stone
<b>BASIC*</b>	A30S-BF	46	●	
	A30S-BF100	47	●	
	C30S-BF	47		●
	C30S-BF100	47		●

Items with grey lettering are only available on request.



**PREMIUM\*\*\* CUT-OFF WHEELS**

For steel



TYROLIT provides the optimal tools for use on large cut-off machines in trade and industry. These include the PREMIUM\*\*\* cut-off wheel for steel in large diameters. This special tool is ideal for cutting workpieces with large cross-sections. As with all TYROLIT PREMIUM\*\*\* cut-off wheels, this tool has been optimised to achieve the best possible cutting ability and lifetime.

Developed for use on manual cut-off machines with electric or petrol engines. Suitable for pure off-hand and guided off-hand applications.

	Shape	Type no.	Dimension	Specification	PU	
		41H	255451	300x3.5x20	A30O-BF02A2	10
		75020	300x3.5x20	A30P5BF71A2	10	
		307876	300x3.5x20	A30Q-BF02A2	10	
		181071	300x3.5x22.23	A30O-BF02A2	10	
		141512	300x3.5x22.23	A30Q-BF02A2	10	
		83618	300x3.5x22.23	A30Q4BF71A2	10	
		514745	300x3.5x22.23	M85A30P4BF91A2	10	
		363478	300x3.5x25.4	A30O-BF02A2	10	
		351693	300x3.5x30	A30N-BF02A2	10	
		366794	300x3.5x30	A30Q-BF02A2	10	
		419688	350x4.0x30	A30N-BF02A2	10	
		623097	400x4.5x40	MA30Q4BF97M2	10	

Smaller-diameter cut-off wheels can be found from page 21, 27.



**PREMIUM\*\*\* CUT-OFF WHEELS**

For rails



This wheel has been developed specially based on specifications for cutting rails. Despite extreme application conditions, such as humidity, cold and temperature fluctuations, the rail cut-off wheel from TYROLIT offers short cutting times coupled with minimal effort. Exceptionally clean, non-discoloured surfaces reduce reworking tasks and working times.

Developed for use on manual cut-off machines with electric or petrol engines. Suitable for pure off-hand and guided off-hand applications.

	Shape	Type no.	Dimension	Specification	PU	
		41H	665900	300x3.2x22.23	A24Q-BF	10
		676423	300x3.5x22.23	A24Q-BF100	10	
		671093	350x3.8x22.23	A24Q-BF100	10	
		671108	350x3.8x25.4	A24Q-BF100	10	
		671090	400x4.3x22.23	A24Q-BF100	10	
		676428	400x4.3x25.4	A24Q-BF100	10	





**PREMIUM\*\*\* CUT-OFF WHEELS**  
For stone



This PREMIUM\*\*\* cut-off wheel achieves the best results due to its excellent cutting ability that reduces the work of the operator. The cut-off wheel delivers the optimum cutting performance on solid material and large

cross-sections. Developed for use on manual cut-off machines with electric or petrol engines. Suitable for pure off-hand and guided off-hand applications.

	Shape	Type no.	Dimension	Specification	PU	
		41H	255450	300x3.5x20	C24O-BF02A2	10
			183592	300x3.5x22.23	C24O-BF02A2	10
			9292	300x4.0x20	C30P4BF71A2	10
			410277	300x4.0x22.23	1C24R6BF38A2	10
			732088	300x4.0x25.4	C247O4BF33A2	10
			668570	350x4.0x20	C24O-BF02A2	10
			548170	350x4.0x25.4	C24O-BF02A2	10



Smaller-diameter cut-off wheels can be found from page 26.

**STANDARD\*\* CUT-OFF WHEELS**  
For steel



TYROLIT provides the optimal tools for use on large cut-off machines in trade and industry. These include the STANDARD\*\* cut-off wheel for steel in large diameters. This special tool is ideal for cutting workpieces with large cross-sections.

Developed for use on manual cut-off machines with electric or petrol engines. Suitable for pure off-hand and guided off-hand applications.

	Shape	Type no.	Dimension	Specification	PU	
		41H	384753	300x3.5x20	A30S-BF	10
			384754	300x3.5x22.23	A30S-BF	10
			384755	300x3.5x25.4	A30S-BF	10
			384756	350x4.0x20	A30S-BF100	10
			384757	350x4.0x22.23	A30S-BF100	10
			384758	350x4.0x25.4	A30S-BF100	10
			386002	400x4.5x20	A30S-BF100	10

Smaller-diameter cut-off wheels can be found from page 31.

## STANDARD★★ CUT-OFF WHEELS

For rails



Despite extreme application conditions, such as humidity, cold and temperature fluctuations, the stone cut-off wheel from TYROLIT offers reduced cutting times coupled with minimal effort. Clean, non-discoloured surfaces reduce reworking tasks and working times.

Developed for use on manual cut-off machines with electric or petrol engines. Suitable for pure off-hand and guided off-hand applications.

	Shape	Type no.	Dimension	Specification	PU
		41H 75937	300x3.5x20	A30S-BFRAIL	10
		75938	300x3.5x22.23	A30S-BFRAIL	10
		75939	300x3.5x25.4	A30S-BFRAIL	10
		75934	350x4.0x20	A30S-BFRAIL100	10
		75935	350x4.0x22.23	A30S-BFRAIL100	10
		75936	350x4.0x25.4	A30S-BFRAIL100	10
		355251	400x4.3x25.4	A30S-BFRAIL100	10

## STANDARD★★ CUT-OFF WHEELS

For stone



The technology from TYROLIT makes it possible to use two external reinforcements for cutting solid material and large cross-sections. This STANDARD★★ cut-off wheel achieves the best results due to its excellent cutting ability that reduces the work of the operator.

Developed for use on manual cut-off machines with electric or petrol engines. Suitable for pure off-hand and guided off-hand applications.

	Shape	Type no.	Dimension	Specification	PU
		41H 384759	300x3.5x20	C30S-BF	10
		384760	300x3.5x22.23	C30S-BF	10
		384761	300x3.5x25.4	C30S-BF	10
		384762	350x4.0x20	C30S-BF100	10
		384763	350x4.0x22.23	C30S-BF100	10
		384764	350x4.0x25.4	C30S-BF100	10
		386001	400x4.5x20	C30S-BF100	10

Smaller-diameter cut-off wheels can be found from page 32.

## BASIC★ CUT-OFF WHEELS



For steel



The BASIC★ cut-off wheel for steel is suitable for cutting profiles, solid material and large cross-sections due to its design with two external reinforcements. With the BASIC★ wheel, you can achieve reduced cutting times coupled with minimal effort.

Developed for use on manual cut-off machines with electric or petrol engines. Suitable for pure off-hand and guided off-hand applications.

	Shape	Type no.	Dimension	Specification	PU
		41H 223035	300x3.5x20	A30S-BF	10
		223037	300x3.5x22.23	A30S-BF	10
		223039	300x3.5x25.4	A30S-BF	10
		223040	300x3.5x32	A30S-BF	10

	Shape		Type no.	Dimension	Specification	PU
		41H	223042	350x4.0x20	A30S-BF100	10
			223043	350x4.0x22.23	A30S-BF100	10
			222045	350x4.0x25.4	A30S-BF100	10

Smaller-diameter cut-off wheels can be found from page 33.



**BASIC★ CUT-OFF WHEELS**

For stone



The technology from TYROLIT makes it possible to use two external reinforcements for cutting solid material and large cross-sections. The BASIC★ cut-off wheel therefore offers good stability and cutting ability, reducing the work of the operator.

Developed for use on manual cut-off machines with electric or petrol engines. Suitable for pure off-hand and guided off-hand applications.

	Shape		Type no.	Dimension	Specification	PU
		41H	223129	300x3.5x20	C30S-BF	10
			223131	300x3.5x22.23	C30S-BF	10
			223132	300x3.5x25.4	C30S-BF	10
			223134	350x4.0x20	C30S-BF100	10
			223135	350x4.0x22.23	C30S-BF100	10
			223136	350x4.0x25.4	C30S-BF100	10

Smaller-diameter cut-off wheels can be found from page 34.





**1.4 CUT-OFF WHEELS  
WITH AND WITHOUT REINFORCEMENT  
FOR STATIONARY CUTTING MACHINES**

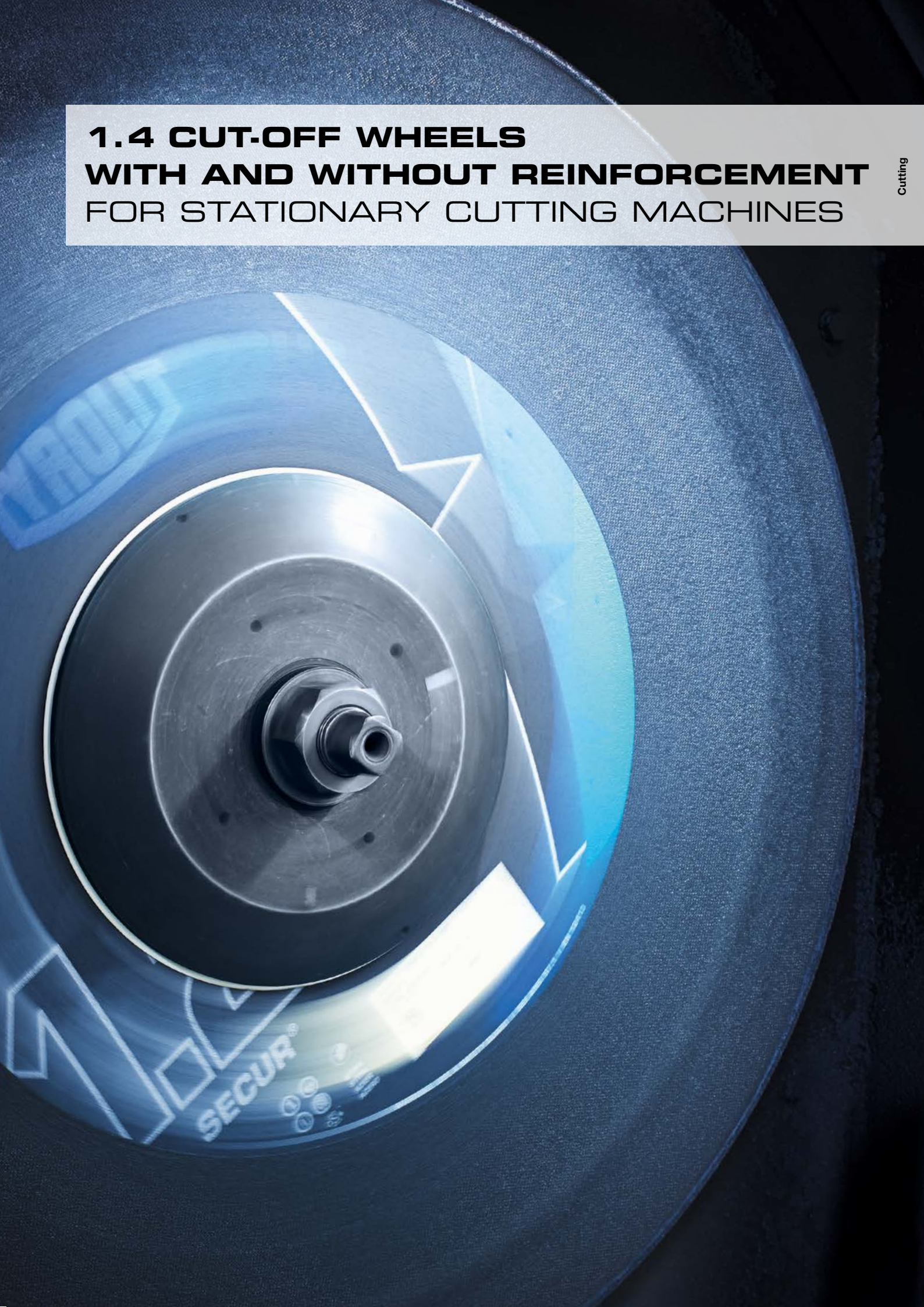



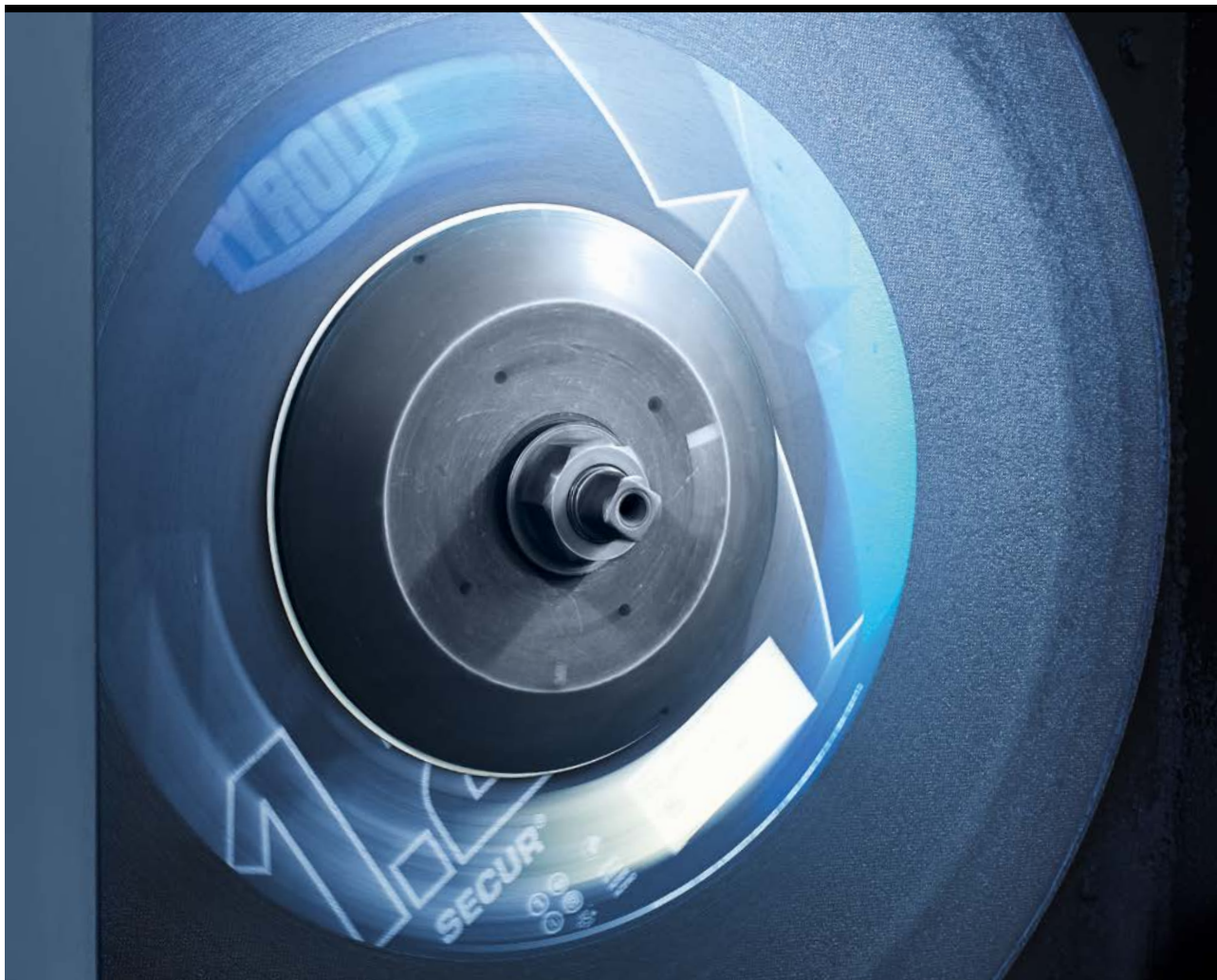

## CUT-OFF WHEELS FOR STATIONARY CUTTING MACHINES

Stationary cutting machines are most commonly used in workshops. They ensure precision cutting of all materials, regardless of diameter.

TYROLIT offers two types of cut-off wheel for this application. Firstly, cut-off wheels with reinforcement that can be used to cut profiles, pipes and solid material. Secondly, non-reinforced cut-off wheels for laboratory

cutting, for cutting and saw sharpening, and for cutting high speed steel.

Whether for use on steel, stainless steel, stone or rails, thanks to the clear colour coding and application

tips, you will always be able to find the right product for your application and the material to be cut. TYROLIT guarantees optimum cutting results and maximum levels of safety in all situations.

# Shape

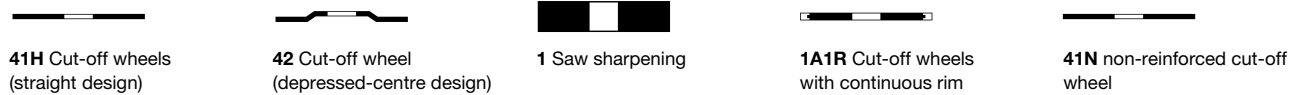

# Application recommendation

Performance level	Specification	Page	Application			
			Steel	Stainless steel	NF metals	Stone
<b>PREMIUM***</b>	... BF71 ...	52	●			
	... BF02 ...	52	●			
	... BF97 ...	53		●		
	... BF68 ...	53		●		
	... BFXM ...	53		●		
	... BF98 ...	53		●		
	... BF59 ...	53			●	
	... BF33 ...	54				●
	C...BF71...	54				●
<b>STANDARD**</b>	A46S-BF	54				●
<b>BASIC*</b>	A46S-BF	55				●

Items with grey lettering are only available on request.



**PREMIUM\*\*\* CUT-OFF WHEELS**

For steel



TYROLIT provides the optimal tools for use on stationary cutting machines in chop cut. These include the PREMIUM\*\*\* cut-off wheel for steel in diameters from 300 to 500 mm. This special tool is ideal for cutting workpieces with large cross-sections, as well as solid material and profiles.

As with all TYROLIT PREMIUM\*\*\* cut-off wheels, this tool has been optimised to achieve the best possible cutting ability and lifetime.

	Shape	Type no.	Dimension	Specification	PU	
		41	779426	300x2.5x25.4	A36N4BF71A2	10
			641977	300x3.0x22.23	A30P4BF71M100	10
			630117	300x3.5x22.23	A30P4BF71M100	10
			636399	300x3.5x25.4	A30P4BF71M100	10
			643371	300x3.5x25.4	A30N-BF02M	10
			630116	300x3.5x32	A30P4BF71M100	10
			140022	300x3.5x30	A30Q-BF02M	10
			151301	300x3.5x32	A30Q-BF02M	10
			598487	300x3.2x22.23	A36N5BF71M	10
			615549	350x2.5x25.4	A46N4BF71M	10
			779428	350x2.5x25.4	A36N4BF71A2	10
			780935	350x3.5x25.4	A36N5BF71M	10
			408229	350x3.5x25.4	A30N-BF02M	10
			309469	350x3.5x25.4	A24P-BF02M	10
			84363	350x3.5x25.4	A30O4BF71M	10
			633286	350x4.0x25.4	A30N-BF02M	10
			780938	400x3.5x25.4	A36N5BF71M	10
			639076	400x4.0x25.4	A30N-BF02M	10
			396678	400x4.0x40	A30N-BF02M	10
			196324	400x4.0x32	A30Q-BF02M	10
	136777	400x4.0x40	A30Q-BF02M	10		
	272894	400x4.0x40	A24P-BF02M	10		
	37348	400x4.0x25.4	A24Q4BF71M	10		
	829562	400x4.0x51	A30N4BF71A2100	10		
	630537	400x4.0x51	A30P5BF71M100	10		
	514338	500x5.5x40	A24O4BF71M100	10		
	722981	500x5.0x25.4	A24Q4BF71M	10		

Thinner cut-off wheels can be found from page 27.



**PREMIUM★★★ CUT-OFF WHEELS**



For stainless steel



TYROLIT provides the optimal tools for use on stationary cutting machines in chop cut. The tool is suitable for cutting metal sheets, profiles, pipes, rods and solid material. Despite its versatile use, the tool offers maximum cutting ability and the longest lifetime.

The chemical purity of this tool is a requirement of machining stainless

steel in order to avoid impairments to the material, such as corrosion, pitting or a reduction in the fatigue strength.

	Shape	Type no.	Dimension	Specification	PU		
		41	647224*	250x2.5x25.4	A24Q4-BF97A2	10	
		559743	300x2.5x25.4	A46N4BF68M	10		
		66490	300x3x25.4	A24O-BFXM	10		
		647229*	300x3.5x32	A24Q4-BF97M	10		
		519232	350x2.5x25.4	A46N4BF68M	10		
		66491	350x3.5x25.4	A24O-BFXM	10		
		94110	350x3.5x32	A24O-BFXM	10		
		647216*	350x3.5x40	A24Q4-BF97M	10		
		538503	400x2.5x25.4	A46N4BF68M	10		
		551616	400x3.0x25.4	A46N4BF68M	10		
		196324	400x4.0x32	A30Q-BF02M	10		
		136777	400x4.0x40	A30Q-BF02M	10		
		66493	400x4.0x40	A24O-BFXM	10		
		647218*	400x4.0x40	A24Q4-BF97M	10		
		460744*	500x5.0x40	A24P4-BF97M	10		
		793077*	500x5.5x25.4	A241P4-BF98M	10		
		647232*	600x6.0x60	A24O4-BF97M2	10		
			42	647684*	400x5.0x60	A24Q4-BF97M	10
				647389*	500x6.0x60	A24P4-BF97M	10
647377*	600x7.0x60			A24O4-BF97M2	10		

\*Also suitable for steel. Thinner diameter cut-off wheels can be found from page 28.



**PREMIUM★★★ CUT-OFF WHEELS**

For nonferrous metals



In order to cut nonferrous metals, the tool must have a high cutting ability. To this end, TYROLIT has developed a special formula and production method in order to be able to perform stationary cutting on NF metals too. New specifications prevent the clogging and dulling of the grinding wheel which used to be a common result of material abrasion.

As with all TYROLIT PREMIUM\*\*\* cut-off wheels, this tool has been optimised to achieve the best possible cutting ability and lifetime.

	Shape	Type no.	Dimension	Specification	PU	
		41	58157	300x3.5x25.4	A30P4BF59M	10
		309471	350x3.5x25.4	A30O4BF59M	10	
		800035	400x4.0x40	A30O4BF59M	10	
		56918	500x5.0x25.4	A30P4BF59M100	10	
		422374	500x5.5x40	A24N5BF59M2	10	

Thinner cut-off wheels can be found from page 29.

**FOCUR SA**

Diamond cut-off wheel for grey and spheroidal cast iron



FOCUR SA diamond cut-off wheels from TYROLIT are the optimum tool for machining grey and spheroidal cast iron. These products combine a long lifetime with maximum economic efficiency. FOCUR SA cut-off wheels are available in diameters from 178 to 600 mm.

	Shape	Type no.	Dimension	Specification	PU
		UC3			
		102814	300x3.0x40	DC CI	1
		102831	350x3.5x40	DC CI	1
		102850	400x4.0x60	DC CI	1
		102855	450x4.0x60	DC CI	1
		102856	500x5.0x60	DC CI	1
		102859	600x5.0x60	DC CI	1

**PREMIUM\*\*\* CUT-OFF WHEELS**

For stone



With this tool you obtain the ideal solution for stationary cutting of common building materials. This PREMIUM\*\*\* cut-off wheel achieves the best results for large cross-sections due to its excellent cutting ability that reduces the work of the operator.

As with all TYROLIT PREMIUM\*\*\* cut-off wheels, this tool has been optimised to achieve the best possible cutting ability and lifetime.

	Shape	Type no.	Dimension	Specification	PU
		41			
		1649	350x4.0x25.4	C2004BF33M	10
		28692	400x4.0x30	C2004BF33M	10
		639799	500x5.0x25.4	C20P4BF71M	10

Smaller-diameter cut-off wheels can be found from page 29.

**STANDARD\*\* CUT-OFF WHEELS**

For steel



TYROLIT provides the optimal tools for use on stationary cutting machines in chop cut. This special tool is ideal for cutting workpieces with large cross-sections, as well as solid material and profiles. The internal reinforcement and rough side surfaces enable low burr cutting of workpieces.

As with all TYROLIT STANDARD\*\* cut-off wheels, this tool has been optimised to achieve excellent cutting ability and lifetime.

	Shape	Type no.	Dimension	Specification	PU
		41			
		390531	300x2.5x25.4	A46S-BF	10
		390532	350x2.8x25.4	A46S-BF	10

Thinner cut-off wheels can be found from page 31.



**BASIC★** CUT-OFF WHEELS

For steel



This special tool is ideal for cutting workpieces with large cross-sections, as well as solid material and profiles. The internal reinforcement and rough side surfaces enable low burr cutting of workpieces.

As with all TYROLIT BASIC\* cut-off wheels, this tool has been optimised to achieve excellent cutting ability and lifetime.

	Shape	Type no.	Dimension	Specification	PU	
		41	223032	300x2.5x25.4	A46S-BF	10
			223033	350x2.8x25.4	A46S-BF	10

**ORDERING EXAMPLE**

Dimensions of the cut-off wheel: 250 x 1.5 x 32 mm  
 Material to be cut: Tool steel workpiece Wst.nr. 1,2312 (40CrmmoS8-6)  
 Hardness: 440 hV / 44.5 HRC  
 Result: Type 167205

	Hardness		Recommended specification		
	Vickers hardness	Rockwell	Hard	Medium	Soft
	1000 HV	72,3 HRC			
	700 HV	60,5 HRC			
	500 HV	49,1 HRC			
	350 HV	35,5 HRC			
	250 HV	22,0 HRC			
	150 HV				
	120 HV				
	80 HV				
	50 HV				
	30 HV				
	<b>Dimension</b>		<b>Type No.</b>	<b>Type No.</b>	<b>Type No.</b>
	432x3,0x32		167352	167351	167344
	400x3,0x32		167340	167339	167338
	350x2,5x32		169477	167334	167333
	300x2,0x32		169479	167226	167225
	250x1,5x32		167207	167205	165940
	230x1,5x32		167219	167215	167214
	<b>Specification</b>		A80-BH	A80-BM	A80-BS

**PREMIUM\*\*\* LAB**

Laboratory for nonferrous metals, plastics and titanium

Application guidelines

- Use sufficient coolant with 2 - 3 % anti-corrosion additive
- Avoid applying too much pressure to prevent any cut deviation

- For larger workpiece dimensions, we recommend using the next softest specification

	Dimension	Type No.		
		NF metals	plastics	Titanium
	432x3.0x32	167354	167351	
	400x3.0x32	167432	167354	
	350x2.5x32	167335	167335	167336
	300x2.0x32	167229	167229	
	250x1.5x32	167210	167210	167211
	230x1.5x32	167220	167220	167221
	<b>Specification</b>	C80-BN	C80-BN	C80-BT

vs < 50 m/sec (higher speed on request)



**PREMIUM★★★ LAB**



For steel and stainless steel



Construction/materials able to be machined: High performance cut-off wheels without reinforcement for ferrous metals; PREMIUM★★★ laboratory cut-off wheel range offers the optimum cut-off wheel for a variety of materials, workpiece dimensions and hardnesses.

Details: For use on stationary machines without reinforcement, so not suitable for hand held applications; workpiece must be fixed, do not expose to lateral load.

- Specification soft for 60.5 – 72.3 HRC
- Specification medium for 22.0 – 60.5 HRC
- Specification hard up to 22.0 HRC

	Shape	Type no.	Dimension	Specification	Classification	PU	
		41N	167219	230x1.5x32	A80-BH50	hard	10
			167215	230x1.5x32	A80-BM50	medium	10
			167214	230x1.5x32	A80-BS50	soft	10
			167207	250x1.5x32	A80-BH50	hard	10
			167205	250x1.5x32	A80-BM50	medium	10
			165940	250x1.5x32	A80-BS50	soft	10
			596848	250x1.8x32	89A60L5B17/50	very easy cutting	10
			169479	300x2.0x32	A80-BH50	hard	10
			167226	300x2.0x32	A80-BM50	medium	10
			167225	300x2.0x32	A80-BS50	soft	10
			597041	300x2.0x32	89A60L5B17/50	very easy cutting	10
			169477	350x2.5x32	A80-BH50	hard	10
			167334	350x2.5x32	A80-BM50	medium	10
			167333	350x2.5x32	A80-BS50	soft	10
			597383	350x2.5x32	89A60J5B17/50	very easy cutting	10
			167340	400x3.0x32	A80-BH50	hard	10
			167339	400x3.0x32	A80-BM50	medium	10
			167338	400x3.0x32	A80-BS50	soft	10
			167352	432x3.0x32	A80-BH50	hard	10
			167351	432x3.0x32	A80-BM50	medium	10
	167344	432x3.0x32	A80-BS50	soft	10		

**PREMIUM★★★ LAB**



For titanium and nonferrous metals



Construction/materials able to be machined: High performance cut-off wheels without reinforcement for nonferrous metals, plastics and titanium

- Sufficient lubricant with 2 – 3% anti-corrosion additive
- Avoid applying too much pressure to prevent any cut deviation.



Details: For use on stationary machines, so not suitable for hand held applications; workpiece must be fixed, do not expose to lateral load. For larger workpiece dimensions, we recommend using the next softest specification.

	Shape	Type no.	Dimension	Specification	Classification	PU	
		41N	167220	230x1.5x32	C80-BN50	Nonferrous / Plastics	10
			167221	230x1.5x32	C80-BT50	Titanium	10
			167210	250x1.5x32	C80-BN50	Nonferrous / Plastics	10
			167211	250x1.5x32	C80-BT50	Titanium	10

**PREMIUM★★★ LAB**

For titanium and nonferrous metals



	Shape	Type no.	Dimension	Specification	Classification	PU	
		41N	167229	300x2.0x32	C80-BN50	Nonferrous / Plastique	10
		167335	350x2.5x32	C80-BN50	Nonferrous / Plastique	10	
		167336	350x2.5x32	C80-BT50 A2	Titanium	10	
		167342	400x3.0x32	C80-BN50	Nonferrous / Plastique	10	
		167354	432x3.0x32	C80-BN50	Nonferrous / Plastique	10	



**PREMIUM★★★**

Cutting and saw sharpening



Construction/materials able to be machined: High-performance cut-off wheels without reinforcement for stationary machines and automated saw sharpening machines.

Details: For use on stationary machines without reinforcement, so not suitable for hand held applications; workpiece must be fixed, do not expose to lateral load.

	Shape	Type no.	Dimension	Specification	PU	
		1	591080*	150x3.0x20	A60O5B68	10
		655529*	200x2.0x25	89A60M5B0	10	
		41N	529392	100x1.0x20	A80N4B2	10
		202159	100x1.0x20	A80N4B68	10	
		46633	100x1.0x20	A80O4B43	10	
		722408	100x1.5x20	A80N4B2	10	
		6673	100x2.0x20	A80N4B2	10	
		88461**	120x2.0x51	A60N4B2	10	
		282077	120x2.0x51	A60N5B68	10	
		608409	120x2.0x51	A60P4B68	10	
		1197	120x2.0x51	A60O5B43	10	
		596269	125x1.0x16	A60O5B68	10	
		25590	125x1.0x20	A60O5B43	10	
		282079	125x1.0x20	A60N5B68	10	
		35917	125x1.0x20	A80O5B43	10	
		282080	125x1.0x20	A80N5B68	10	
		282078	125x1.5x20	A60N5B68	10	
		614686	150x1.0x16	A60P5B68	10	
		282110	150x1.0x20	A60N5B68	10	
		1211	150x1.0x20	A60O5B43	10	
591103	150x1.0x20	A60O5B68	10			
282111	150x1.0x20	A80N5B68	10			
13695	150x1.0x20	A80O5B43	10			
594360	150x1.0x20	A80O5B68	10			

\* For saw sharpening only. \*\* Also suitable for saw sharpening.

	Shape	Type no.	Dimension	Specification	PU	
		41N	39110	150x1.0x32	A80O5B43	10
		8833	150x1.5x20	A60O5B43	10	
		282085	150x1.5x20	A60N5B68	10	
		591104	150x1.5x20	A60O5B68	10	
		282105	150x1.5x20	A80N5B68	10	
		79957	150x1.5x20	A80O5B43	10	
		662430	150x1.5x32	A80N5B68	10	
		42808	150x1.6x20	A60P4B43	10	
		227165	150x1.6x32	A60O5B43	10	
		58158	150x1.6x32	A60P4B43	10	
		15685	150x2.0x20	A60O5B43	10	
		32023	150x2.0x20	A60N4B2	10	
		282112	150x2.0x20	A60N5B68	10	
		594362	150x2.0x20	A60O5B68	10	
		594356	150x2.0x30	A60O5B68	10	
		33436	150x2.0x30	A60N4B2	10	
		594357	150x2.0x30	A60Q5B68	10	
		648577	150x2.0x32	A60O4B68	10	
		80143	150x2.0x32	A80N4B2	10	
		223516**	150x2.5x20	A60N4B2	10	
		598971	150x2.5x20	A60O5B68	10	
		591680	150x2.5x30	A60Q5B68	10	
		596520	175x2.0x51	A60P4B68	10	
		607744	175x3.0x51	A60P4B68	10	
		675283	180x1.0x32	A60O5B43	10	
		493199	180x1.6x32	A60O5B68	10	
		282113	200x1.5x20	A60N5B68	10	
		1254	200x1.5x20	A60O5B43	10	
		282114	200x1.5x32	A60N5B68	10	
		6718	200x1.5x32	A60O4B43	10	
		42809	200x1.6x25.4	A60P4B43	10	
		230691	200x1.6x32	A60M4B43	10	
		205822	200x1.6x32	A60P4B43	10	
		6710**	200x2.0x20	A60N4B2	10	
		96205**	200x2.0x32	A60N4B2	10	
		62874	200x2.0x32	A60N4B43	10	
97442	200x2.5x32	A60N4B2	10			
12970**	200x3.0x32	A60N4B2	10			
863284	200x3.0x32	A60P4B68	10			
599666	230x1.5x22.2	89A60N4B68	10			

\* For saw sharpening only. \*\* Also suitable for saw sharpening.

**PREMIUM★★★**

## Cutting and saw sharpening



Construction/materials able to be machined: High-performance cut-off wheels without reinforcement for stationary machines and automated saw sharpening machines.

Details: For use on stationary machines without reinforcement, so not suitable for hand held applications; workpiece must be fixed, do not expose to lateral load.

	Shape	Type no.	Dimension	Specification	PU	
		41N	373520	250x1.5x25.4	A6005B71	10
			834839	250x1.6x32	89A80L4B43	10
			549002	300x2.0x31.75	89A80L4B43	10
			60572	300x2.0x32	A8005B71	10
			220394	400x2.8x25.4	89A60L4B59	10

\* For saw sharpening only. \*\* Also suitable for saw sharpening.

**PREMIUM★★★**

## Cutting HSS



Construction/materials able to be machined: High performance cut-off wheels for cutting high speed steel; cost-effective with diamond tools.

Details: automatic feed and sealed application.

	Shape	Type no.	Dimension	V-X	Specification	PU	
		1A1R	788700	125x1.0x20	1-5	B126 C75 B	1
			164485	125x1.0x20	1-5	B151 C100 B	1
			494701	150x1.0x20	1-5	B151 C100 B	1

**PREMIUM★★★**

## Cutting cemented carbide



Construction/materials able to be machined: High performance cut-off wheels for cutting cemented carbide; cost-effective with diamond tools.

Details: automatic feed and sealed application.

	Shape	Type no.	Dimension	V-X	Specification	PU	
		1A1R	157800	75x0.8x20	0.8-5	D126 C75 B	1
			119395	100x0.8x20	0.8-5	D126 C100 B	1
			100660	100x1.0x20	41030	D126 C100 B	1
			108728	100x1.5x20	1.5-5	D126 C75 B	1
			101000	125x1.0x20	41030	D126 C100 B	1
			148132	150x1.0x20	41030	D126 C100 B	1
			317532	150x1.0x20	41030	D126 C75 B	1
			278979	150x1.0x20	41030	D151 C100 B	1
			667995	200x1.0x22	41030	D126 C100 B	1
			858531	200x1.2x20	1.2-7	D126 C100 B	1
			603284	200x1.2x30	1.2-7	D151 C100 B	1







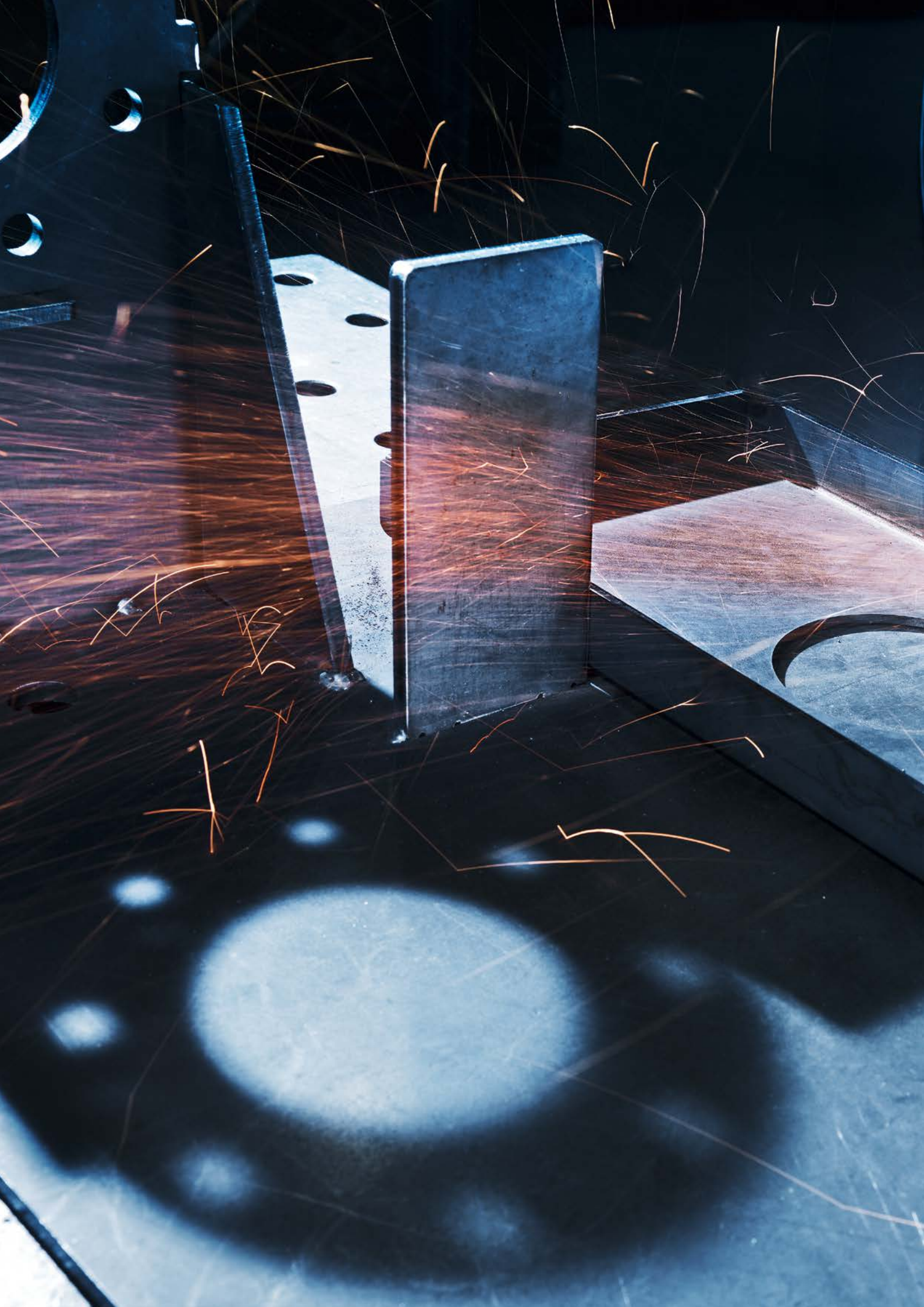





# CATALOGUE 18 GRINDING

<b>Grinding information</b>	<b>64</b>
Explanation of labels	64
Specification	65
Machine pictograms	65
<b>Angle grinders</b>	<b>67</b>
2.1 Rough grinding wheels	68
2.2 Rondeller®	85
2.3 Cup wheels	89
<b>Straight grinders</b>	<b>95</b>
2.4 Grinding wheels	96
Accessories	99
2.5 Mounted points	101
Resin mounted points	105
Ceramic mounted points	106
Elastic mounted points	112
2.6 Tungsten carbide burrs	113

# SPECIFIC INFORMATION

## RESIN-BONDED GRINDING WHEELS

### Cut-off wheels product label



### Colour codes

<b>Label:</b>	Steel	2in1/3in1	INOX	Nonferrous metals	Cast iron	Stone
<b>Colour code:</b>	Blue	Blue	Red	Orange	Purple	Green
<b>Material:</b>	Steel	2in1 = Steel and stainless steel, 3in1 = Steel, stainless steel and cast iron	Stainless steel	Aluminium, copper, zinc, brass, bronze, stone	Cast materials	Stone



## Cut-off wheels specification

### A24Q-BFX

X	TYROLIT internal designation
F	Fibre-reinforced: Fibre glass (safety, lateral load, operating speed)
B	Bonding agent: B/Resin
Q	Designation of hardness: N, O, P, Q, R, S, T
24	Grit size 30 in mesh: usually 24, 30, 36, 46, 60, 80, 120
A	Abrasive: A ... Regular aluminium oxide, C ... Silicon carbide, ZA ... Zirconia alumina

## Pictograms for machines



Angle grinder



Pneumatic angle grinder



Angle grinder with cup wheels



Straight grinder







## **2.1 ROUGH GRINDING WHEELS FOR ANGLE GRINDERS**



## ROUGH GRINDING WHEELS FOR ANGLE GRINDERS

Working with an angle grinder is one of the most important processes in the handicraft and industrial sectors for machining all types of metals. TYROLIT offers the perfect rough grinding wheels for convenient and quick use with small and large angle grinders.

The TYROLIT range of rough grinding wheels meets the most stringent demands for cost-effective working, high stock removal rates, simple handling and above-average lifetimes. Our high-performance rough grinding wheels deliver the best results in both standard and special applications.

Continuous developments, such as the introduction of the „Comfort Start“ edge, with which every user

can achieve optimum results right from the start, make our rough grinding wheels one of the most advanced tools in the sector.

Working safety and comfort, provided for example by the vibration-damped VIBSTAR rough grinding wheel and the noise reducing SILENTIO, are also of great importance to us.

All TYROLIT rough grinding wheels are manufactured and tested in accordance with EN12413. Uniform colour coding helps you to find the appropriate product for your application.

### Shapes



27 rough grinding wheel



27V rough grinding wheel (VIBSTAR vibration-damped)



27SI rough grinding wheel (SILENTIO noise-reduced)



28CON rough grinding wheel (CONFLEX)



# Application recommendation



Performance Level	Specification	Pages	Steel	Stainless steel	2in1	NF metals	Cast iron	3in1	Stone
<b>PREMIUM***</b>	A30R-BFX	75, 76, 77		●					
	A30S-BFX	LONGLIFE 70	●						
	A30Q-BFX	2in1 72, 73, 74			●				
	A36N-BFX	77				●			
	A36L-BFX	77				●			
	ZA24N-BFX	FOCUR Extra 79					●		
	ZA24P-BFX	FOCUR Extra 79					●		
	ZZA24R-BFX	FOCUR Extra 79, 80					●		
	C30S-BFX	80							●
	ZA30Q-BFR	3in1 74						●	
	ZZA24T-BFK	T-GRIND 78		●			●		
	A24O-BFX	2in1 73			●				
	CA24Q-BFK	2in1 71			●				
	ZZA24S-BFX	FOCUR Extra 79, 80					●		



Performance Level	Specification	Pages	Steel	Stainless steel	Cast iron	Stone
<b>STANDARD**</b>	A30R-BFINOX	81		●		
	A24S-BF	80	●			
	ZA30-BF	FOCUR 81			●	
	C30S-BF	81				●



Performance Level	Specification	Pages	2in1	Cast iron	Stone	Stainless steel/ NF metals
<b>BASIC*</b>	A30Q-BF	82	●			
	AC30N-BF	83		●		
	C30S-BF	83			●	
	A30P-BF	82		●		
	WA46R-BF	TOUCH 83				●



Items with grey lettering are only available on request.

**PREMIUM\*\*\*** ROUGH GRINDING WHEEL  
 LONGLIFE for steel



The PREMIUM\*\*\* LONGLIFE is a high-performance rough grinding wheel for surface and edge grinding. The 4 mm thick rough grinding wheel achieves the highest stock removal rates, such as in pipeline construction applications.

The 7, 8 and 10 mm thick LONGLIFE rough grinding wheels offer enhanced dimensional stability for welding and root welding.

	Shape	Type no.	Dimension	Specification	PU
	 27	5279	100x6.0x16	A30S-BFX	10
		5288	115x4.0x22.23	A30S-BFX	10
		5294	115x7.0x22.23	A30S-BFX	10
		5306	125x4.0x22.23	A30S-BFX	10
		5314	125x7.0x22.23	A30S-BFX	10
		843037	150x4.0x22.23	A30S-BFX	10
		5331	150x7.0x22.23	A30S-BFX	10
		5350	178x4.0x22.23	A30S-BFX	10
		5363	178x7.0x22.23	A30S-BFX	10
		5384	178x8.0x22.23	A30S-BFX	10
		5396	178x10.0x22.23	A30S-BFX	10
		5407	230x4.0x22.23	A30S-BFX	10
		5413	230x7.0x22.23	A30S-BFX	10
		5429	230x8.0x22.23	A30S-BFX	10



# PREMIUM★★★ ROUGH GRINDING WHEEL CERABOND 2IN1 FOR STEEL AND STAINLESS STEEL

**+ Improved productivity**

A special structural composition offers maximum system performance.

**+ Shorter work processes**

Working times are substantially reduced through improved abrasiveness.



Rough grinding wheel with and without „Comfort Start“.

**+ Lower production costs**

The unique bond technology, optimised for ceramic grain, prevents the grain break-out and leads to a longer lifetime for the tool.

The TYROLIT CERABOND system brings almost 100 years of experience to a new generation of highest performance tools. With the rough grinding wheels from the CERABOND family, we have succeeded in achieving an ideal combination of

specially treated ceramic grain and bond structure.

Thus it is possible to keep the abrasiveness and the lifetime of the wheel at the highest level. The unique bond system prevents premature grain

break-out in order to guarantee the full grinding power of the individual grains. This rough grinding wheel is particularly suitable for steel and stainless steel applications.

**PREMIUM★★★ ROUGH GRINDING WHEEL  
CERABOND 2in1 for steel and stainless steel**



	Shape	Type no.	Dimension	Specification	PU
		34060373	115x4.0x22.23	CA24Q-BFK	5
		34019874*	115x7.0x22.23	CA24Q-BFK	5
		34060374	125x4.0x22.23	CA24Q-BFK	5
		34019876*	125x7.0x22.23	CA24Q-BFK	5
		34060375	150x4.0x22.23	CA24Q-BFK	5
		34019877*	150x7.0x22.23	CA24Q-BFK	5
		34060376	178x4.0x22.23	CA24Q-BFK	5
		34019878*	178x7.0x22.23	CA24Q-BFK	5
		34060377	230x4.0x22.23	CA24Q-BFK	5
		34019879*	230x7.0x22.23	CA24Q-BFK	5

\*With Comfort Start edge

# PREMIUM\*\*\* ROUGH GRINDING WHEEL 2IN1 FOR STEEL AND STAINLESS STEEL

- + **Enhanced economic efficiency**  
High abrasiveness coupled with a significantly longer lifetime.
- + **Less work required**  
The destruction of the work-piece as a result of plunging with the tool is prevented, thus avoiding rework.



Rough grinding wheel with and without „Comfort Start“.

- + **Enhanced comfort while working**  
With the „Comfort Start“ function, plunging into the workpiece is prevented, thus making the start of the process simpler and more convenient.

**TYROLIT Film**



The product film can be found on YouTube at [www.youtube.com/TYROLITgroup](http://www.youtube.com/TYROLITgroup)

This rough grinding wheel is particularly suitable for steel and stainless steel applications. Due to its softer design, the PREMIUM\*\*\* 2in1 is quick and convenient to use and requires minimal effort. This is made possible

by a new bond with coarser grain and a new layer composition.

What makes our 2in1 rough grinding wheel so unique is the bevelled and defined edge of the tool. With the

“Comfort Start” edge, the user can achieve a pleasant start to grinding and the level of comfort while working is increased many times over.

**PREMIUM\*\*\* ROUGH GRINDING WHEEL**  
2in1 for steel and stainless steel



	Shape	Type no.	Dimension	Specification	PU	
		27	5270	75x6.0x9.5	A30Q-BFX	10
			23875	100x4.0x16	A30Q-BFX	10
			34046119*	100x6.0x16	A24Q-BFX	10
			5287	115x4.0x22.23	A30Q-BFX	10
			34046120*	115x7.0x22.23	A24Q-BFX	10
			5308	125x4.0x22.23	A30Q-BFX	10
			34046131*	125x7.0x22.23	A24Q-BFX	10
			734378	150x4.0x22.23	A30Q-BFX	10
			34046132*	150x7.0x22.23	A24Q-BFX	10

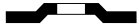

	Shape	Type no.	Dimension	Specification	PU	
		27	5349	178x4.0x22.23	A30Q-BFX	10
		34046133*	178x7.0x22.23	A24Q-BFX	10	
		545254	178x7.0x22.23	A24O-BFX	10	
		34046135*	178x8.0x22.23	A24Q-BFX	10	
		5406	230x4.0x22.23	A30Q-BFX	10	
		34046134*	230x7.0x22.23	A24Q-BFX	10	
		545255	230x7.0x22.23	A24O-BFX	10	
		34046136*	230x8.0x22.23	A24Q-BFX	10	
		545256	230x10.0x22.23	A24O-BFX	10	
		34046137*	230x10.0x22.23	A24Q-BFX	10	

\* With Comfort Start edge

# PREMIUM★★★ ROUGH GRINDING WHEEL SILENTIO 2IN1 FOR STEEL AND STAINLESS STEEL

+ **Enhanced economic efficiency**  
Maximum stock removal rate and a long lifetime for stainless steel applications.

+ **Enhanced work safety**  
The sound insulation reduces lasting physical strain.



+ **Universal use**  
The PREMIUM\*\*\* Silentio rough grinding wheel is equally suitable for surface and edge grinding on steel and stainless steel.



The PREMIUM\*\*\* Silentio sets new milestones in terms of noise reduction. With a reduction of 10 decibels, noise perception is minimised by 50%.

This increases the user's level of comfort while working, avoiding lasting physical harm. This rough grinding wheel has been developed

for stainless steel applications and is suitable for use with both steel and stainless steel.

**PREMIUM\*\*\* ROUGH GRINDING WHEEL**  
SILENTIO 2in1 for steel and stainless steel



	Shape	Type no.	Dimension	Specification	PU	
		27SI	285439	230x8.0x22.23	A30Q-BFX	10

**PREMIUM\*\*\* ROUGH GRINDING WHEEL**  
CONFLEX for steel and stainless steel



With the PREMIUM\*\*\* CONFLEX the optimum grinding angle is already preset due to the wheel shape. This makes horizontal machine guiding possible, facilitating the user's work.

Using the optimal angle makes it possible to achieve consistent wear of the tool and an even surface. This rough grinding wheel is particularly suitable for steel and stainless steel applications.

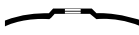

	Shape	Type no.	Dimension	Specification	PU	
		28CON	5267	178x7.0x22.23	A30Q-BFX	10

**PREMIUM\*\*\* ROUGH GRINDING WHEEL**  
3in1 for steel, stainless steel and cast iron



With the PREMIUM\*\*\* 3in1 rough grinding wheel with zirconium aluminium oxide you can impress on three levels. High performance on steel, stainless steel and cast materials, as well as chemical purity distinguish the product. This tool does not contain iron, sulphur, chlorine and fluorine, and leaves workpiece surfaces in a neutral condition.

The abrasiveness and long lifetime enable high stock removal rates within the shortest possible time. Thanks to its chemical purity; free of iron, sulphur, chlorine and fluorine, the wheel is particularly suited to special application areas such as nuclear power stations.



	Shape	Type no.	Dimension	Specification	PU	
		27	466744	115x7.0x22.23	ZA30Q-BFR	10
			466749	125x7.0x22.23	ZA30Q-BFR	10
			466754	178x7.0x22.23	ZA30Q-BFR	10
			466762	230x7.0x22.23	ZA30Q-BFR	10

**PREMIUM\*\*\* ROUGH GRINDING WHEEL**  
For stainless steel



The high-performance rough grinding wheel has been specially designed for stainless steel applications. The PREMIUM\*\*\* INOX rough grinding wheel combines a long lifetime and the best cutting ability.

To achieve this a special mixture of regular aluminium oxide and zirconium aluminium oxide is used. This rough grinding wheel is specially designed for stainless steel applications.

	Shape	Type no.	Dimension	Specification	PU	
		27	117058	100x6.0x16	A30R-BFX	10
		117064	115x4.0x22.23	A30R-BFX	10	
		117065	115x7.0x22.23	A30R-BFX	10	
		117068	125x4.0x22.23	A30R-BFX	10	
		117070	125x7.0x22.23	A30R-BFX	10	
		34042874	150x4.0x22.23	A30R-BFX	10	
		34042875	150x7.0x22.23	A30R-BFX	10	
		117071	178x4.0x22.23	A30R-BFX	10	
		117072	178x7.0x22.23	A30R-BFX	10	
		117073	230x4.0x22.23	A30R-BFX	10	
		117074	230x7.0x22.23	A30R-BFX	10	

**PREMIUM\*\*\* ROUGH GRINDING WHEEL**  
**VIBSTAR FOR STAINLESS STEEL**

+ **More even surfaces**  
Vibrations from the tool can also impair the surface finish; the PREMIUM VIBSTAR helps to prevent this.

+ **Enhanced work safety**  
A significant reduction in the vibrational load prevents occupational illnesses.



+ **Reduced costs**  
Vibration damping also increases the lifetime of the machine.



The vibration damping developed and patented by TYROLIT allows professional users to achieve exceptionally gentle grinding. The multi-layer structure and the

permanently attached plastic flange reduce vibrations by up to 50%. The PREMIUM\*\*\* VIBSTAR technology helps to prevent occupational illnesses, such as muscular and skeletal

damage, and neurological illnesses and circulatory problems, such as vibration white finger. This rough grinding wheel is specially designed for stainless steel applications.

**PREMIUM\*\*\* ROUGH GRINDING WHEEL**  
VIBSTAR for stainless steel



	Shape	Type no.	Dimension	Specification	PU	
		27V	474524	178x7.0x22.23	A30R-BFX	10
			474526	230x7.0x22.23	A30R-BFX	10

**PREMIUM\*\*\* ROUGH GRINDING WHEEL**  
**SILENTIO FOR STAINLESS STEEL**

+ **Enhanced economic efficiency**  
Maximum stock removal rate and a long lifetime for stainless steel applications.

+ **Enhanced work safety**  
The sound insulation reduces lasting physical strain.



+ **Universal use**  
The PREMIUM\*\*\* Silentio rough grinding wheel is equally suitable for surface and edge grinding on stainless steel.

The PREMIUM\*\*\* Silentio sets new milestones in terms of noise reduction. With a reduction of 10 decibels, noise perception is minimised by 50%.

This increases the user's level of comfort while working, avoiding lasting physical harm. This rough grinding wheel with

a unique wheel shape has been specially designed for stainless steel applications.

**PREMIUM\*\*\* ROUGH GRINDING WHEEL**  
SILENTIO for stainless steel

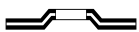

	Shape	Type no.	Dimension	Specification	PU	
		27SI	515988	178x7.0x22.23	A30R-BFX	10
			515989	230x8.0x22.23	A30R-BFX	10





**PREMIUM\*\*\* ROUGH GRINDING WHEEL**  
**CONFLEX for stainless steel**



With the PREMIUM\*\*\* CONFLEX the optimum grinding angle is already preset due to the wheel shape. This makes horizontal machine guiding possible, facilitating the user's work.

Using the optimal angle makes it possible to achieve consistent wear of the tool and an even surface. This rough grinding wheel is specially designed for stainless steel applications.

	Shape	Type no.	Dimension	Specification	PU
		28CON 13616	230x7.0x22.23	A30R-BFX	10



**PREMIUM\*\*\* ROUGH GRINDING WHEEL**  
**For nonferrous metals**



The PREMIUM\*\*\* rough grinding wheel developed specifically for non-ferrous metals prevents clogging of the tool in order to reduce loading or dulling. Even at very low pressure, the wheel achieves extremely high abrasiveness.

stock removal rates to be obtained for nonferrous metal applications. These rough grinding wheels are available in the hard N grade for surface and edge grinding, or in the softer cutting L grade for surface grinding.

TYROLIT's formula and production methods enable exceptionally high

	Shape	Type no.	Dimension	Specification	PU	
		27	45919	100x6.0x16	A36N-BFX	10
		5289	115x4.0x22.23	A36N-BFX	10	
		5295	115x7.0x22.23	A36N-BFX	10	
		636789	125x4.0x22.23	A36N-BFX	10	
		5316	125x7.0x22.23	A36N-BFX	10	
		913338	150x4.0x22.23	A36N-BFX	10	
		47763	150x7.0x22.23	A36N-BFX	10	
		5351	178x4.0x22.23	A36N-BFX	10	
		5365	178x7.0x22.23	A36N-BFX	10	
		46586	230x4.0x22.23	A36N-BFX	10	
		5416	230x7.0x22.23	A36N-BFX	10	
		576049	115x7.0x22.23	A36L-BFX	10	
		647549	125x7.0x22.23	A36L-BFX	10	
		576050	178x7.0x22.23	A36L-BFX	10	
		647550	230x7.0x22.23	A36L-BFX	10	

# PREMIUM\*\*\* ROUGH GRINDING WHEEL T-GRIND FOR STEEL AND CAST IRON

**+ High productivity**

The combination of a long lifetime and high abrasiveness significantly increases the productivity of this rough grinding wheel.

**+ Cost-effective**

Due to the above-average lifetime of the T-GRIND, purchase and disposal costs are reduced.



**+ Highest demands**

Meets the highest demands of powerful pneumatic angle grinders.



The PREMIUM\*\*\* T-GRIND has been developed for the high demands exerted when using turbine and vane-type pneumatic grinders. The long

lifetime ensures this rough grinding wheel provides a vast reduction in abrasive waste, making it an environmentally-friendly product.

At the same time, the aggressive stock removal rate ensures more comfort and relief for the user while working.

**PREMIUM\*\*\* ROUGH GRINDING WHEEL**  
T-GRIND for steel and cast iron





	Shape	Type no.	Dimension	Specification	PU	
		27	701518	125x7x22.23	ZZA24T-BFK	10
			701439	178x7x22.23	ZZA24T-BFK	10
			701515	230x7x22.23	ZZA24T-BFK	10

**PREMIUM\*\*\* ROUGH GRINDING WHEEL**  
**FOCUR Extra for cast iron**



The PREMIUM\*\*\* FOCUR Extra offers maximum stock removal rates coupled with the longest lifetime. Innovative production technology combined with high-quality zirconium aluminium oxide makes this possible. This high-performance tool has been developed for application on all cast materials and can be used for surface grinding, deburring work and rendering.

ZA24N-BFX: particularly for surface grinding, ZA24P-BFX: universal type, ZZA24R-BFX: the deburring specialist and ZZA24S-BFX: for long lifetimes.

Shape	Type no.	Dimension	Specification	PU
  27	233756	125x7.0x22.23	ZA24N-BFX	10
	233757	178x4.0x22.23	ZA24N-BFX	10
	233759	178x7.0x22.23	ZA24N-BFX	10
	233760	230x4.0x22.23	ZA24N-BFX	10
	233762	230x7.0x22.23	ZA24N-BFX	10
	233765	125x7.0x22.23	ZA24P-BFX	10
	233768	178x7.0x22.23	ZA24P-BFX	10
	233771	230x7.0x22.23	ZA24P-BFX	10
	233773	125x7.0x22.23	ZZA24R-BFX	10
	233774	178x4.0x22.23	ZZA24R-BFX	10
	233776	178x7.0x22.23	ZZA24R-BFX	10
	233777	230x4.0x22.23	ZZA24R-BFX	10
	233778	230x7.0x22.23	ZZA24R-BFX	10
	929017	178x4.0x22.23	ZZA24S-BFX	10
	929018	178x7.0x22.23	ZZA24S-BFX	10
	929019	230x4.0x22.23	ZZA24S-BFX	10
	929020	230x7.0x22.23	ZZA24S-BFX	10



**PREMIUM\*\*\* ROUGH GRINDING WHEEL**  
**FOCUR Extra VIBSTAR for cast iron**



The vibration damping developed and patented by TYROLIT allows professional users to achieve exceptionally gentle grinding. The multi-layer structure and the permanently attached plastic flange reduce vibrations by up to 50%.

The PREMIUM\*\*\* VIBSTAR technology helps to prevent occupational illnesses, such as muscular and skeletal damage, and neurological illnesses

and circulatory problems, such as vibration white finger. ZA24N-BFX: particularly for surface grinding, ZA24P-BFX: universal type, ZZA24R-BFX: the deburring specialist and ZZA24S-BFX: for long lifetimes.



Shape	Type no.	Dimension	Specification	PU
  27V	474527	178x7.0x22.23	ZA24N-BFX	10
	474532	230x7.0x22.23	ZA24N-BFX	10
	474528	178x7.0x22.23	ZA24P-BFX	10
	474533	230x7.0x22.23	ZA24P-BFX	10

**PREMIUM\*\*\*** ROUGH GRINDING WHEEL  
FOCUR Extra VIBSTAR for cast iron



The vibration damping developed and patented by TYROLIT allows professional users to achieve exceptionally gentle grinding. The multi-layer structure and the permanently attached plastic flange reduce vibrations by up to 50%.  
The PREMIUM\*\*\* VIBSTAR technology helps to prevent occupational

illnesses, such as muscular and skeletal damage, and neurological illnesses and circulatory problems, such as vibration white finger. ZA24N-BFX: particularly for surface grinding, ZA24P-BFX: universal type, ZZA24R-BFX: the deburring specialist and ZZA24S-BFX: for long lifetimes.



	Shape	Type no.	Dimension	Specification	PU
		27V			
		474529	178x7.0x22.23	ZZA24R-BFX	10
		474534	230x7.0x22.23	ZZA24R-BFX	10
		474531	178x7.0x22.23	ZZA24S-BFX	10
		474535	230x7.0x22.23	ZZA24S-BFX	10

**PREMIUM\*\*\*** ROUGH GRINDING WHEEL  
For stone



The abrasive PREMIUM\*\*\* rough grinding wheel for stone is quick and convenient to use and requires minimal exertion. It is ideal for soft to hard stone, natural and artificial stone and concrete.

This rough grinding wheel with silicon carbide is specifically for stone and short-chipping materials.



	Shape	Type no.	Dimension	Specification	PU
		27			
		5368	178x7x22.23	C30S-BFX	10
		5425	230x7x22.23	C30S-BFX	10

**STANDARD\*\*** ROUGH GRINDING WHEEL  
For steel



The STANDARD\*\* rough grinding wheel is a powerful rough grinding wheel for surface and edge grinding. The tool boasts optimised cutting ability and a long lifetime.

Even with low pressure, the wheel is abrasive and easy to handle.

	Shape	Type no.	Dimension	Specification	PU
		27			
		368002	100x6.0x16	A24S-BF	10
		367377	115x6.0x22.23	A24S-BF	10
		367771	125x6.0x22.23	A24S-BF	10
		367772	150x6.0x22.23	A24S-BF	10
		367773	178x6.0x22.23	A24S-BF	10
		367775	230x6.0x22.23	A24S-BF	10



**STANDARD\*\* ROUGH GRINDING WHEEL**  
For stainless steel



The powerful rough grinding wheel has been specially designed for stainless steel applications. The STANDARD\*\* INOX rough grinding wheel combines a long lifetime and the best cutting ability.

This is achieved through the use of regular aluminium oxide. This rough grinding wheel is specially designed for stainless steel applications.

	Shape	Type no.	Dimension	Specification	PU
		368014	100x6.0x16	A30R-BFINOX	10
		367545	115x6.0x22.23	A30R-BFINOX	10
		367548	125x6.0x22.23	A30R-BFINOX	10
		367550	150x6.0x22.23	A30R-BFINOX	10
		367551	178x6.0x22.23	A30R-BFINOX	10
		367553	178x8.0x22.23	A30R-BFINOX	10
		367554	230x6.0x22.23	A30R-BFINOX	10
		367556	230x8.0x22.23	A30R-BFINOX	10

**STANDARD\*\* ROUGH GRINDING WHEEL**  
For stone



The abrasive STANDARD\*\* rough grinding wheel for stone is quick and convenient to use and requires minimal exertion. It is ideal for soft to hard stone, natural and artificial stone and concrete.

This rough grinding wheel with silicon carbide is specifically for stone and short-chipping materials.

	Shape	Type no.	Dimension	Specification	PU
		368008	100x6.0x16	C30S-BF	10
		367546	115x6.0x22.23	C30S-BF	10
		367549	125x6.0x22.23	C30S-BF	10
		367552	178x6.0x22.23	C30S-BF	10
		367557	230x6.0x22.23	C30S-BF	10

**STANDARD\*\* ROUGH GRINDING WHEEL**  
FOCUR for cast iron



With the STANDARD\*\* FOCUR rough grinding wheel you will obtain a tool that has been optimised in terms of its cutting ability and offers a high level of dimensional stability. Even with low pressure, the tool is abrasive and durable.

This powerful tool has been developed for application on all cast materials and can be used for surface grinding, deburring work and rendering.

	Shape	Type no.	Dimension	Specification	PU
		154544	178x7.0x22.23	ZA300-BF	10
		154545	230x7.0x22.23	ZA300-BF	10

**BASIC★ ROUGH GRINDING WHEEL**  
2in1 for steel and stainless steel



This rough grinding wheel is particularly suitable for steel and stainless steel applications due to its softer design. In addition, the BASIC\* 2in1 is quick and convenient to use and requires minimal effort.

This tool can be used universally and is equally suitable for surface and edge grinding applications.

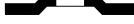

	Shape	Type no.	Dimension	Specification	PU	
		27	222854	100x6.0x16	A30Q-BF	10
		222858	115x6.0x22.23	A30Q-BF	10	
		222860	125x6.0x22.23	A30Q-BF	10	
		222861	150x6.0x22.23	A30Q-BF	10	
		222863	178x6.0x22.23	A30Q-BF	10	
		222868	178x8.0x22.23	A30Q-BF	10	
		222865	230x6.0x22.23	A30Q-BF	10	
		222870	230x8.0x22.23	A30Q-BF	10	

**BASIC★ ROUGH GRINDING WHEEL**  
FASTCUT 2in1 for steel and stainless steel



This rough grinding wheel is particularly suitable for steel and stainless steel applications. Due to its soft design, the BASIC\* FASTCUT 2in1 is optimised in its cutting ability in order to achieve high stock removal rates in the shortest possible time.

This tool can be used universally and is equally suitable for surface and edge grinding applications.



	Shape	Type no.	Dimension	Specification	PU	
		27	297324	100x6.0x16	A30P-BF	10
		297325	115x6.0x22.23	A30P-BF	10	
		297327	125x6.0x22.23	A30P-BF	10	
		297329	150x6.0x22.23	A30P-BF	10	
		297331	178x6.0x22.23	A30P-BF	10	
		297333	230x6.0x22.23	A30P-BF	10	

**BASIC★ ROUGH GRINDING WHEEL**  
PIPELINER 2in1 for steel and stainless steel



The Basic\* PIPELINER has been developed for V-groove applications. Specifically in pipeline construction, it is necessary to chamfer the pipe ends in order to subsequently weld them together. As they only comprise one grain layer, they provide for even wear on the workpiece.

The PIPELINER is a 2in1 rough grinding wheel and is therefore equally suitable for steel and stainless steel.



	Shape	Type no.	Dimension	Specification	PU	
		27	734693	178x7.0x22.23	A30Q-BF PIPE	10

**BASIC★ ROUGH GRINDING WHEEL**  
For stone



The abrasive BASIC\* rough grinding wheel for stone is quick and convenient to use and requires minimal exertion. It is ideal for soft to hard stone, natural and artificial stone and concrete.

This rough grinding wheel with silicon carbide is specifically for stone and short-chipping materials.

	Shape		Type no.	Dimension	Specification	PU
		27	222872	100x6.0x16	C30S-BF	10
			222873	115x6.0x22.23	C30S-BF	10
			222889	125x6.0x22.23	C30S-BF	10
			222892	150x6.0x22.23	C30S-BF	10
			222043	178x6.0x22.23	C30S-BF	10
			222898	230x6.0x22.23	C30S-BF	10

**BASIC★ ROUGH GRINDING WHEEL**  
For cast iron



With the BASIC\* rough grinding wheel for cast iron you will obtain a tool that has been specially designed for rendering and offers a high level of dimensional stability. Even with low pressure, the tool is easy cutting and durable.

This tool has been developed for application on all cast materials and is particularly suitable for smoothing cast materials.

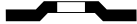

	Shape		Type no.	Dimension	Specification	PU
		27	567352	178x8.0x22.23	AC30N-BF	10
			567353	230x8.0x22.23	AC30N-BF	10

**BASIC★ GRINDING WHEEL**  
TOUCH for stainless steel and nonferrous metals



The semi-flexible BASIC\* TOUCH combines the advantages of various products in one tool. The "waffle" structure enables cool grinding with good chip transport. In addition, the risk of material discolouration is reduced. The unique structure and low weight of the TOUCH suppresses vibrations, ensuring quiet operation and sound reduction.

The wheel also facilitates ideal adaptation to workpieces for grinding, deburring and shaping work. It is also possible to cut nonferrous metals.

	Shape		Type no.	Dimension	Specification	PU
		29T	236317	100x16	WA46R-BF	25
			236318	115x22.23	WA46R-BF	25
			236319	125x22.23	WA46R-BF	25
			236320	178x22.23	WA46R-BF	25





TYROLIT





**2.2 RONDELLER®**  
FOR ANGLE GRINDERS



# RONDELLER® FOR ANGLE GRINDERS

Working with an angle grinder is one of the most important processes in the handicraft and industrial sectors for machining all types of metals. TYROLIT has developed a special tool for use on an angle grinder that combines the product advantages of different grinding tools. It is not necessary to use any special accessories with the Rondeller®, so simple handling is guaranteed.

Its unique geometry and stud pattern enable outstanding stock removal, cool, material-protecting grinding and ergonomic working. Vibration-free



working and perfect adaptation to the workpiece is guaranteed when grinding, deburring and shaping curved surfaces.

## Shapes



29 RON  
Rondeller®

## Application recommendation

Performance Level	Specification	Pages			
<b>PREMIUM★★★</b>	A...Q-BF	87	●		
	C...S-BF	88		●	●

Items with grey lettering are only available on request.

# PREMIUM\*\*\* RONDELLER®

## 2IN1 FOR STEEL AND STAINLESS STEEL

+ **High level of comfort while working**  
 These tools make vibration-free, ergonomic use possible and protect both user and machine.

+ **Universal use**  
 Ideal for use on steel and stainless steel, as well as for all grinding, deburring and shaping applications on curved surfaces.



+ **Simple handling**  
 Easy assembly - no need to use special accessories, such as back up pads and clamping nuts.

The TYROLIT PREMIUM\*\*\* RONDELLER® combines the product advantages of different grinding tools with the easiest handling. The unique geometry of the Rondeller® enables

cool, ergonomic grinding that is kind to materials.

Absolutely vibration-free use and optimal adaptation to the workpiece for

all grinding, deburring and shaping applications means that curved surfaces can be perfectly machined.

### PREMIUM\*\*\* RONDELLER®

2in1 for steel and stainless steel



Shape	Type no.	Dimension	Specification	PU	
	29RON	57004	115x22.23	A24Q-BF	25
	908225	115x22.23	A36Q-BF	25	
	908226	115x22.23	A60Q-BF	25	
	57005	125x22.23	A24Q-BF	25	
	908227	125x22.23	A36Q-BF	25	
	908229	125x22.23	A60Q-BF	25	
	33199	125x22.23	A80Q-BF	25	
	170599	150x22.23	A36Q-BF	25	
	57006	178x22.23	A24Q-BF	25	
	908230	178x22.23	A36Q-BF	25	
	908231	178x22.23	A60Q-BF	25	

**PREMIUM\*\*\* RONDELLER®**  
For stone



The TYROLIT PREMIUM\*\*\* RONDELLER® combines the product advantages of different grinding tools with the easiest handling. The unique geometry and stud pattern of the RONDELLER® enables ergonomic grinding that protects materials. Absolutely vibration-free use and optimal adaptation to the workpiece for all grinding jobs means that curved surfaces can be perfectly machined.

	Shape	Type no.	Dimension	Specification	PU	
		29RON	908233	115x22.23	C36S-BF	25
			948218	115x22.23	C60S-BF	25
			908220	178x22.23	C36S-BF	25
			908221	178x22.23	C60S-BF	25
			908223	178x22.23	C100S-BF	25
			908224	178x22.23	C180S-BF	25





## 2.3 CUP WHEELS FOR ANGLE GRINDERS





## CUP WHEELS FOR ANGLE GRINDERS

Working with an angle grinder is one of the most important processes in the handicraft and industrial sectors for machining all types of metals. The use of cup wheels is recommended when grinding large and heavy components in particular, as they are exceptionally robust and durable.

It is particularly important to ensure that cup wheels are only used on angle grinders for 178 mm diameters. Smaller machines rotate too quickly, while larger ones rotate too slowly. In addition, a special protection cover is required to ensure sufficient levels of working safety.

With cup wheels from TYROLIT you can achieve high stock removal rates and long lifetime. The composition of the cup wheels makes them suitable for large-area machining of welding seams or for grinding imperfections on concrete surfaces. TYROLIT cup wheels can not only be used for metal





machining, but also on marble, slate and granite.

Uniform colour coding helps you to find the appropriate product for your application.

## Shapes



## Application recommendation

Performance Level	Specification	Pages			
			Steel	Stainless steel	Stone
<b>PREMIUM</b> ★★★	A... B84	92	●		
	A... B2	92		●	
	1C... B0	92, 93			●
	1C... B2	92, 93			●
					
Performance Level	Specification	Pages	Steel	Stone	
<b>STANDARD</b> ★★	A... B	93	●		
	C... B	93			●

Items with grey lettering are only available on request.

**PREMIUM\*\*\* RESIN CUP WHEEL**

For steel



Cup wheels achieve maximum stock removal rates and lifetime for grinding jobs on large areas. The PREMIUM\*\*\* cup wheel for steel is ideal for edge grinding, bevelling and grinding welding seams.

There is a choice of bore design 22.23 and thread design M14 for fitting to the tool. Observe operating speed: max. 50 m/s

	Shape	Type no.	Dimension	Specification	PU	Max. speed	
		11BT	310183	110/90x55x22.23	A16P4B84	2	8,680
			311096	110/90x55x22.23	A36O4B84	2	8,680
		351386	130/90x55x22.23	A16P4B84	2	7,340	
		310997	130/90x55x22.23	A36O4B84	2	7,340	
		11ZB	321395	110/90x55xM14	A16P4B84	2	8,680
			310184	110/90x55xM14	A36O4B84	2	8,680
			377664	130/90x55xM14	A36O4B84	2	7,340
		11ZT	241413	102/76x51x5/8"	A16P4B84	2	9,360
			23525	152/120x51x5/8"	A16P4B84	2	6,280

**PREMIUM\*\*\* RESIN CUP WHEEL**

For Inox



Cup wheels achieve maximum stock removal rates and lifetime for grinding jobs on large areas. The PREMIUM\*\*\* cup wheel specially designed for stainless steel is also ideal for edge grinding, bevelling and grinding welding seams.

There is a choice of bore design 22.23 and thread design M14 for fitting to the tool. Observe operating speed: max. 50 m/s

	Shape	Type no.	Dimension	Specification	PU	Max. speed	
		11ZT	23509	127/94x51x5/8"	A20M4B2	2	7,510
			275634	152/120x51x5/8"	A20M4B2	2	6,280

**PREMIUM\*\*\* RESIN CUP WHEEL**

For stone





Cup wheels achieve maximum stock removal rates and lifetime for grinding jobs on large areas. The stone cup wheel is particularly suitable for pre-grinding imperfections on concrete surfaces, bevelling and pre-grinding artificial stone and patio slabs, surface grinding on marble, slate and granite.

There is a choice of bore design 22.23 and thread design M14 for fitting to the tool. Observe operating speed: max. 50 m/s

	Shape	Type no.	Dimension	Specification	PU	Max. speed	
		11BT	310980	110/90x55x22.23	1C16L4B2	2	8,680
			318070	110/90x55x22.23	1C24L4B2	2	8,680
			342583	110/90x55x22.23	1C46K4B2	2	8,680
			314463	110/90x55x22.23	1C60J4B2	2	8,680
			317307	110/90x55x22.23	1C120J4B0	2	8,680



	Shape	Type no.	Dimension	Specification	PU	Max. speed	
		6ZB	89383	100x45xM14	1C24L4B2	2	9,540
			83585	100x45xM14	1C60J4B2	2	9,540
			56895	100x45xM14	1C120J4B2	2	9,540
			553403	100x45xM14	1C220J4B0	2	9,540
		11ZB	310992	110/90x55xM14	1C16L4B2	2	8,680
			310993	110/90x55xM14	1C24L4B2	2	8,680
			321211	110/90x55xM14	1C60J4B2	2	8,680
			320074	110/90x55xM14	1C120J4B0	2	8,680
			326214	110/90x55xM14	1C220J4B0	2	8,680
			310994	130/90x55xM14	1C16L4B2	2	7,340
			310995	130/90x55xM14	1C24L4B2	2	7,340
			320075	130/90x55xM14	1C60J4B2	2	7,340
			424846	130/90x55xM14	1C120J4B0	2	7,340
			336499	130/90x55xM14	1C220J4B0	2	7,340

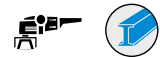

**STANDARD\*\* RESIN CUP WHEEL**

For steel



Cup wheels achieve excellent stock removal rates and lifetime for grinding jobs on large areas. The STANDARD\*\* cup wheel for steel is ideal for edge grinding, bevelling and grinding welding seams.

There is a choice of bore design 22.23 and thread design M14 for fitting to the tool. Observe operating speed: max. 50 m/s

	Shape	Type no.	Dimension	Specification	PU	Max. speed	
		11BT	895678	110/90x55x22.23	A16P-B	2	8,680
			895669	110/90x55x22.23	A36P-B	2	8,680

**STANDARD\*\* RESIN CUP WHEEL**



For stone



Cup wheels achieve excellent stock removal rates and lifetime for grinding jobs on large areas. The stone cup wheel is particularly suitable for pre-grinding imperfections on concrete surfaces, bevelling and pre-grinding artificial stone and patio slabs, surface grinding on marble, slate

and granite.

There is a choice of bore design 22.23 and thread design M14 for fitting to the tool. Observe operating speed: max. 50 m/s

	Shape	Type no.	Dimension	Specification	PU	Max. speed	
		11BT	895679	110/90x55x22.23	C16J-B	2	8,680
			895670	110/90x55x22.23	C36J-B	2	8,680
			895671	110/90x55x22.23	C60J-B	2	8,680
		11ZB	895676	110/90x55xM14	C16J-B	2	8,680
			895677	110/90x55xM14	C60J-B	2	8,680







## **2.4 GRINDING WHEELS** FOR STRAIGHT GRINDERS



## GRINDING WHEELS FOR STRAIGHT GRINDERS

Straight grinders are always in high demand when precise results are required on difficult-to-access areas. Their versatile application options make them a popular tool. In order to fulfil the high standards TYROLIT sets for itself, great importance was attached to the low-vibration grinding properties of the products during their design.

The range easily meets the general demands of economic efficiency, high stock removal rates, simple handling and above-average lifetimes.

All TYROLIT rough grinding wheels are manufactured and tested in accord-

ance with EN12413. Uniform colour coding helps you to find the appropriate product for your application.



# Shapes

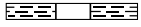

**1F80**  
Rough grinding wheel

# Application recommendation



Performance Level	Specification	Pages	Steel	Stainless steel	NF metals	Cast iron
<b>PREMIUM</b> ★★★	A30R-BFX80	98		●		
	A30S-BFX80	98	●			
	A36N-BFX80	99			●	
	ZA24P-BFX80	99				●

Items with grey lettering are only available on request.

**PREMIUM\*\*\* GRINDING WHEELS**

1F80 for steel



The PREMIUM\*\*\* 1F80 high-performance rough grinding wheel is particularly suitable for universal grinding tasks on hard-to-reach areas. Using the wheel, flutes and notches can be added, and gears can be deburred. In addition, the wheel makes light work of maintaining turbine blades, and

rough grinding curved surfaces in cavities and ridges. For diameters above 80 mm, we recommend using a protection cover.

	Shape	Type no.	Dimension	Specification	PU	
		1F80	439061	50x6.0x6	A30S-BFX80	100
		441231	50x10.0x6	A30S-BFX80	100	
		441207	50x10.0x10	A30S-BFX80	100	
		441226	60x6.0x10	A30S-BFX80	100	
		441219	60x10.0x10	A30S-BFX80	100	
		441233	70x10.0x10	A30S-BFX80	100	
		441223	75x6.0x10	A30S-BFX80	100	
		441227	75x25.0x13	A30S-BFX80	100	
		441238	100x6.0x8	A30S-BFX80	25	
		441239	175x25.0x16	A30S-BFX80	20	

**PREMIUM\*\*\* GRINDING WHEELS**

1F80 for stainless steel



The PREMIUM\*\*\* 1F80 high-performance rough grinding wheel is particularly suitable for universal grinding tasks on hard-to-reach areas. Using the wheel, flutes and notches can be added, and gears can be deburred. In addition, the wheel makes light work of maintaining turbine blades, and

rough grinding curved surfaces in cavities and ridges. For diameters above 80 mm, we recommend using a protection cover.

	Shape	Type no.	Dimension	Specification	PU	
		1F80	439059	50x6.0x6	A30R-BFX80	100
		441206	50x10x10	A30R-BFX80	100	
		441245	50x19.0x10	A30R-BFX80	100	
		441243	75x4.0x10	A30R-BFX80	100	
		441224	75x15.0x10	A30R-BFX80	100	
		441203	100x25.0x25	A30R-BFX80	25	
		441204	125x25.0x25	A30R-BFX80	20	
		441241	150x25.0x25	A30R-BFX80	20	

**PREMIUM\*\*\* GRINDING WHEELS****1F80 for nonferrous metals**

The PREMIUM\*\*\* 1F80 high-performance rough grinding wheel is particularly suitable for universal grinding tasks on hard-to-reach areas. This product has been specially developed for nonferrous metals and is ideal for adding flutes and notches, as well as deburring gears. In addition, the wheel makes light work of maintaining turbine blades, and

rough grinding curved surfaces in cavities and ridges. For diameters above 80 mm, we recommend using a protection cover.

	Shape	Type no.	Dimension	Specification	PU	
		1F80	441247	50x10.0x10	A36N-BFX80	100
		441248	75x6.0x10	A36N-BFX80	100	
		441246	75x25.0x20	A36N-BFX80	100	
		441230	100x12.0x22.2	A36N-BFX80	25	
		441250	100x20.0x20	A36N-BFX80	25	

**PREMIUM\*\*\* GRINDING WHEELS****1F80 for cast iron**

The PREMIUM\*\*\* 1F80 high-performance rough grinding wheel is particularly suitable for universal grinding tasks on hard-to-reach areas. This product has been specially developed for cast iron and is ideal for adding flutes and notches.

In addition, the wheel makes light work of rough grinding curved surfaces in cavities and ridges. For diameters above 80 mm, we recommend using a protection cover.

	Shape	Type no.	Dimension	Specification	PU	
		1F80	441353	150x25.0x25	ZA24P-BFX80	20

**ACCESSORIES****For 1F80 rough grinding wheels**

These accessories are suitable for clamping all rough grinding wheels available in the TYROLIT assortment for straight grinders. Please observe the maximum permissible speed.

	Type no.	Dimension	Specification	PU	
	100SS	803404	S6/H10/M10	SS171	1
	846441	S10/H10/M10	SS173	1	
	846442	S6/H6/M6	SS174	1	







## **2.5 MOUNTED POINTS** FOR STRAIGHT GRINDERS



## MOUNTED POINTS FOR STRAIGHT GRINDERS

Straight grinders are always in high demand when precise results are required on difficult-to-access areas. Their versatile application options make straight grinders a popular tool. In order that there is always a solution at hand for the numerous applications, TYROLIT offers a wide range of mounted point shapes.

Our resin-bonded points offer you vibration-reducing solutions for the highest quality requirements. The wide range of applications also requires ceramic points that strike a perfect balance in terms of chip per-

formance, surface finish and lifetime. Ceramic points are often used in foundries and in mould making. For fine machining, our range also includes elastic and polishing points tailored to your needs.

# Shapes



52ZY / 52W Mounted point

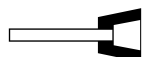

52TO Mounted point



52KE Mounted point

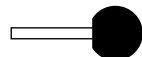

52KU Mounted point

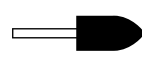

52SP Mounted point



52WR Mounted point



52MS Mounted point



52W Mounted point



52A1 Mounted point

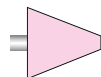

52A2 Mounted point



52A3 Mounted point



52A4 Mounted point

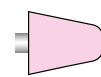

52A5 Mounted point



52A8 Mounted point

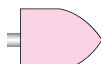

52A9 Mounted point



52A11 Mounted point

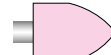

52A12 Mounted point



52A13 Mounted point

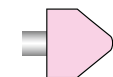

52A14 Mounted point



52A15 Mounted point

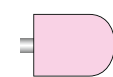

52A19 Mounted point

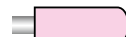

52A24 Mounted point

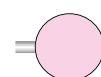

52A25 Mounted point

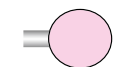

52A26 Mounted point



52A32 Mounted point



52A36 Mounted point



52A37 Mounted point



52-B44 Mounted point

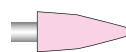

52B-52 Mounted point

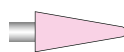

52B-53 Mounted point

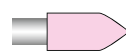

52B-54 Mounted point

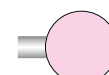

52-B121 Mounted point

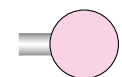

52-B122 Mounted point

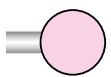

52-B123 Mounted point

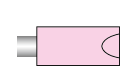

52-B135 Mounted point

## Application recommendation



Performance Level	Specification	Pages	Steel	Stainless steel	NF metals	Cast iron	HSS	PVC
<b>PREMIUM***</b>	<b>Resin points</b>	105, 106						
	... B0	105		•				
	... B84	105, 106				•		
	<b>Ceramic points</b>	106, 107, 108, 109, 110, 111						
	88A ...	106, 107, 108, 109, 110		•				
	89A ...	110, 111					•	
	<b>Elastic mounted points</b>	112						
	... BE13	112		•	•	•		•
	... BE15	112		•	•	•		•
	... BE16	112		•	•	•		•
	... BE24	112		•	•	•		•

Items with grey lettering are only available on request.

## Mounted point dimensions

16 x 20 – 6 x 40

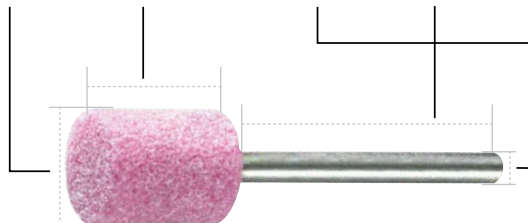



**PREMIUM\*\*\* RESIN BONDED MOUNTED POINTS**

For stainless steel



The PREMIUM\*\*\* resin mounted points have a vibration reducing effect due to their composition and therefore boast low impact sensitivity. Due to their special quality, these points are best suited to deburring, bevelling and edge breaking on stainless steel.

Due to their bond, they are specially suited to INOX materials. Maximum operating speed: 50 m/s

	Shape	Type no.	Dimension	Specification	PU
		52ZY			
		682101	8x16-6x40	A36Q4B0	25
		682103	10x20-6x40	A36Q4B0	25
		34053928	10x32-6x40	A36Q4B0	25
		682104	13x25-6x40	A36Q4B0	25
		682105	16x32-6x40	A36Q4B0	25
		682106	20x32-6x40	A36Q4B0	25
		682107	20x40-6x40	A36Q4B0	25
		34053929	25x13-6x40	A36Q4B0	25
		682110	25x32-6x40	A36Q4B0	25
		34053930	32x16-6x40	A36Q4B0	25
		104962	32x40-6x40	A36Q4B0	25
		104968	40x10-6x40	A36Q4B0	25
		682111	40x20-6x40	A36Q4B0	25
		34053942	50x13-6x40	A36Q4B0	25
682112	50x25-6x40	A36Q4B0	25		

**PREMIUM\*\*\* RESIN BONDED MOUNTED POINTS**

For cast iron

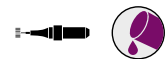

The PREMIUM\*\*\* resin mounted points (dark brown) have a vibration reducing effect due to their composition and therefore boast low impact sensitivity. Due to their special quality, these points are best suited to deburring, bevelling and edge breaking on cast iron materials.

Due to their bond, they are specially suited to casting. Maximum operating speed: 50 m/s

	Shape	Type no.	Dimension	Specification	PU
		52ZY			
		108261	10x25-6x40	A36Q4B84	25
		2111	13x25-6x40	A36Q4B84	25
		108262	15x25-6x40	A36Q4B84	25
		104604	16x32-6x40	A36Q4B84	25
		105367	20x25-6x40	A36Q4B84	25
		2211	25x32-6x40	A36Q4B84	25
		379653	32x25-6x40	A46S4B84	25
		2249	32x40-6x40	A36Q4B84	25
		415841	40x4-6x40	A60S3B84	25
		45362	40x16-8x50	A24Q4B84	25
		2258	40x20-6x40	A36Q4B84	25





**PREMIUM\*\*\* RESIN BONDED MOUNTED POINTS**

For cast iron



The PREMIUM\*\*\* resin mounted points (dark brown) have a vibration reducing effect due to their composition and therefore boast low impact sensitivity. Due to their special quality, these points are best suited to deburring, bevelling and edge breaking on cast iron materials.

Due to their bond, they are specially suited to casting. Maximum operating speed: 50 m/s

Shape	Type no.	Dimension	Specification	PU	
	52ZY	123696	40x25-6x40	A36Q4B84	25
		2284	50x25-6x40	A36Q4B84	25
	52W	21094	10x32-6x40	A46S4B84	25
		21125	13x40-6x40	A46S4B84	25
		21137	16x25-6x40	A46S4B84	25
		310504	16x50-6x40	A46S4B84	25
		21160	20x25-6x40	A46S4B84	25
		21166	20x40-6x40	A46S4B84	25
		21192	25x25-6x40	A46S4B84	25
		21202	25x40-6x40	A46S4B84	25
		169543	32x20-6x40	A46P4B84	25
		123644	32x32-6x40	A46P4B84	25
		21232	32x64-8x40	A20Q4B84	25
		21233	40x6-6x40	A46S4B84	25
	21239	40x13-6x40	A46S4B84	25	
	52A-1	803833	20x63-6x40	A46P4B84	25
	52A-11	126460	22x50-6x40	A46P4B84	25
	52A-11	20026	22x50-6x40	A46S4B84	25
	52A-3	129260	25x70-6x40	A46P4B84	25

**PREMIUM\*\*\* CERAMIC POINTS**

For steel



In foundries and mould making, using ceramic mounted points is often the only method of achieving improved surface results on hard-to-reach parts. TYROLIT PREMIUM\*\*\* mounted points offer the highest possible lifetime even for hardened steels.

These tools also strike a perfect balance in terms of chip performance and the intended surface finish. Maximum operating speed: 50 m/s

Shape	Type no.	Dimension	Specification	PU	
	52ZY	2010	3x6-3x30	88A90O5V38	25
		100757	3x6-6x40	88A90O5V38	25
		169096	3x9-3x30	88A90O5V38	25
		2017	4x8-3x30	88A90O5V38	25
		100758	4x8-6x40	88A60P5V38	25
		2021	4x8-6x40	88A90O5V38	25
		2026	5x10-3x30	88A60P5V38	25



Shape	Type no.	Dimension	Specification	PU
 52ZY	2027	5x10-3x30	88A90O5V38	25
	2031	5x10-6x40	88A60P5V38	25
	11362	6x10-3x30	88A60P5V38	25
	2039	6x10-6x40	88A60P5V38	25
	2046	6x13-3x30	88A60P5V38	25
	485338	6x13-3x30	88A90O5V38	25
	2048	6x13-6x40	88A60P5V38	25
	227450	6x20-3x30	88A60P5V38	25
	116725	6x20-6x40	88A60P5V38	25
	2055	8x10-3x30	88A60P5V38	25
	2058	8x10-6x40	88A60P5V38	25
	2060	8x16-3x30	88A60P5V38	25
	2062	8x16-6x40	88A60P5V38	25
	16044	10x2-3x30	88A90O5V38	25
	120033	10x10-3x30	88A60P5V38	25
	6879	10x10-6x40	88A60P5V38	25
	88905	10x13-3x30	88A60P5V38	25
	2072	10x13-6x40	88A60P5V38	25
	2078	10x20-3x30	88A60P5V38	25
	2081	10x20-6x40	88A60P5V38	25
	14364	10x25-6x40	88A60P5V38	25
	2090	10x32-6x40	88A60P5V38	25
	26567	13x3-3x30	88A90O5V38	25
	128618	13x10-6x40	88A60P5V38	25
	6896	13x16-6x40	88A60P5V38	25
	6898	13x20-6x40	88A60P5V38	25
	6899	13x25-6x40	88A60P5V38	25
	112542	13x40-6x40	88A60P5V38	25
	2117	16x4-6x40	88A60P5V38	25
	6920	16x20-6x40	88A60P5V38	25
	2125	16x25-6x40	88A60P5V38	25
	2133	16x32-6x40	88A36P5V38	25
	2134	16x32-6x40	88A60P5V38	25
	6928	16x50-6x40	88A60P5V38	25
127347	20x6-6x40	88A60P5V38	25	
2145	20x10-6x40	88A60P5V38	25	
2148	20x20-6x40	88A60P5V38	25	
140351	20x25-6x40	88A24P5V38	25	
2163	20x25-6x40	88A36P5V38	25	
6932	20x25-6x40	88A46P5V38	25	
2165	20x25-6x40	88A60P5V38	25	

**PREMIUM\*\*\* CERAMIC POINTS**

For steel

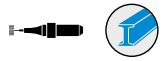





























In foundries and mould making, using ceramic mounted points is often the only method of achieving improved surface results on hard-to-reach parts. TYROLIT PREMIUM\*\*\* mounted points offer the highest possible lifetime even for hardened steels.

These tools also strike a perfect balance in terms of chip performance and the intended surface finish. Maximum operating speed: 50 m/s

Shape	Type no.	Dimension	Specification	PU	
	52ZY	105009	20x32-6x40	88A60P5V38	25
		667629	20x40-6x40	88A24P5V38	25
		12836	20x40-6x40	88A36P5V38	25
		2189	20x40-6x40	88A60P5V38	25
		6941	25x6-6x40	88A60P5V38	25
		122868	25x10-6x40	88A60P5V38	25
		6943	25x13-6x40	88A60P5V38	25
		130009	25x25-6x40	88A36P5V38	25
		2201	25x25-6x40	88A46P5V38	25
		2202	25x25-6x40	88A60P5V38	25
		142682	25x32-6x40	88A24P5V38	25
		2209	25x32-6x40	88A46P5V38	25
		2204	25x32-6x40	88A60P5V38	25
		548169	25x40-6x40	88A36P5V38	25
		2238	32x8-6x40	88A60P5V38	25
		131231	32x10-6x40	88A60P5V38	25
		6959	32x16-6x40	88A46P5V38	25
		6961	32x20-6x40	88A46P5V38	25
		242270	32x20-6x40	88A60P5V38	25
		116973	32x32-6x40	88A36P5V38	25
		103394	32x32-6x40	88A46P5V38	25
		2248	32x40-6x40	88A46P5V38	25
		101508	40x6-6x40	88A60P5V38	25
		667632	40x10-6x40	88A24P5V38	25
		2256	40x10-6x40	88A60P5V38	25
		941497	40x13-6x40	88A30P5V38	25
		734828	40x13-6x40	88A36P5V38	25
		273756	40x20-6x40	88A24P5V38	25
		6967	40x20-6x40	88A46P5V38	25
		15383	40x20-6x40	88A60P5V38	25
		150085	40x25-6x40	88A46P5V38	25
		828192	40x40-6x40	88A36P5V38	25
	2276	50x13-6x40	88A60P5V38	25	
	6974	50x25-6x40	88A46P5V38	25	





Shape	Type no.	Dimension	Specification	PU	
	52A-24	128	6x20-6x40	88A60P5V38	25
	52A-15	97785	6x27-6x40	88A60P5V38	25
		89504	6x27-6x40	88A90O5V38	25
	52A-26	130	16-6x40	88A60P5V38	25
	52A-14	45422	18x22-6x40	88A60P5V38	25
	52A-12	121	18x32-6x40	88A46P5V38	25
		20037	18x32-6x40	88A60P5V38	25
	52A-5	11481	20x29-6x40	88A36P5V38	25
		116	20x29-6x40	88A46P5V38	25
		20023	20x29-6x40	88A60P5V38	25
	52A-8	146601	20x51-6x40	88A36P5V38	25
	52A-1	106372	20x63-6x40	88A36P5V38	25
		108	20x63-6x40	88A46P5V38	25
		109	20x63-6x40	88A60P5V38	25
	52A-11	148517	22x50-6x40	88A36P5V38	25
		118	22x50-6x40	88A46P5V38	25
		20031	22x50-6x40	88A60P5V38	25
	52A-25	20047	25-6x40	88A60P5V38	25
	52A-32	131	25x16-6x40	88A60P5V38	25
	52A-2	88504	25x32-6x40	88A46P5V38	25
	52A-3	11480	25x70-6x40	88A36P5V38	25
		6207	25x70-6x40	88A46P5V38	25
		104894	25x70-6x40	88A60P5V38	25
	52A-37	139	32x6-6x40	88A60P5V38	25
	52A-4	113	32x32-6x40	88A46P5V38	25
		20020	32x32-6x40	88A60P5V38	25
	52A-13	45421	32x32-6x40	88A60P5V38	25
	52A-9	127775	32x51-6x40	88A36P5V38	25
	52A-19	135853	32x51-6x40	88A36P5V38	25
	52A-36	138	40x10-6x40	88A60P5V38	25
	52B-44	169	6x10-3x30	88A60P5V38	25
	52B-54	132438	6x13-3x30	88A60P5V38	25
	52B-135	151928	6x13-3x30	88A60P5V38	25
	52B-53	39128	8x16-3x30	88A90O5V38	25
	52B-122	191	10-3x30	88A60P5V38	25
	52B-121	62694	13-6x40	88A60P5V38	25
	52B-52	174	10x20-3x30	88A60P5V38	25
		75647	10x20-6x40	88A60P5V38	25
	52B-121	190	13-3x30	88A60P5V38	25

**PREMIUM\*\*\* CERAMIC POINTS**

For steel



In foundries and mould making, using ceramic mounted points is often the only method of achieving improved surface results on hard-to-reach parts. TYROLIT PREMIUM\*\*\* mounted points offer the highest possible lifetime even for hardened steels.

These tools also strike a perfect balance in terms of chip performance and the intended surface finish. Maximum operating speed: 50 m/s

	Shape	Type no.	Dimension	Specification	PU	
		52KE	6400	13x13-6x40, R=2	88A60P5V38	25
		6401	6401	16x16-6x40, R=2.5	88A60P5V38	25
		6402	6402	20x20-6x40, R=3	88A60P5V38	25
		330772	330772	20x32-6x40, R=3	88A60P5V38	25
		892	892	25x25-6x40, R=4	88A60P5V38	25
		441033	441033	30x40-6x40, R=5	89A60M5V38	25
		52TO	1175	32x25-6x40	88A60P5V38	25
		52SP	1119	5x10-6x40	88A60P5V38	25
		6660	6660	13x20-6x40, R=22	88A60P5V38	25
		6661	6661	20x32-6x40, R=36	88A60P5V38	25
		52KU	907	3-3x30	88A90O5V38	25
		6404	6404	5-3x30	88A90O5V38	25
		910	910	8-3x30	88A60P5V38	25
		6405	6405	8-6x30	88A60P5V38	25
		917	917	20-6x40	88A60P5V38	25
		921	921	32-6x40	88A46P5V38	25
		1999	1999	6x16-6x40	88A60P5V38	25

**PREMIUM\*\*\* CERAMIC POINTS**



For HSS



Tool steels display exceptional hardness and strength depending on their intended purpose. The PREMIUM\*\*\* mounted points for HSS offer the best prerequisites for machining workpieces up to the lowest tolerance ranges.

These tools also strike a perfect balance in terms of chip performance and the intended surface finish. Maximum operating speed: 35 m/s

	Shape	Type no.	Dimension	Specification	PU	
		52ZY	2011	3x6-3x30	89A120M5V38	25
		2020	2020	4x8-3x30	89A120M5V38	25
		2030	2030	5x10-3x30	89A80M5V38	25
		29238	29238	6x13-3x30	89A80M5V38	25
		13529	13529	6x13-6x40	89A80M5V38	25

	Shape	Type no.	Dimension	Specification	PU	
		52ZY	2057	8x10-3x30	89A80M5V38	25
		6874	8x10-6x40	89A80M5V38	25	
		113299	8x16-3x30	89A80M5V38	25	
		120093	8x16-6x40	89A60M5V38	25	
		6881	10x13-6x40	89A80M5V38	25	
		15892	10x20-6x40	89A60M5V38	25	
		6886	10x20-6x40	89A80M5V38	25	
		6910	15x40-6x40	89A46L5V38	25	
		36663	16x20-6x40	89A60M5V38	25	
		121385	20x25-6x40	89A60M5V38	25	
		2180	20x40-6x40	89A46L5V38	25	
		124549	40x10-6x40	89A60M5V38	25	

**PREMIUM\*\*\* SET CERAMIC POINTS**

For Steel



The PREMIUM\*\*\* ceramic mounted point set contains all the common mounted points for working on steel, including a roughing stone. The points provide the longest possible lifetime for deburring, bevelling and edging work.

These tools also strike a perfect balance in terms of chip performance and the intended surface finish.

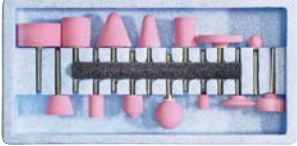
SET	Type no.	Shape	Type no.	Dimension	PU
	74499	52ZY-W228	6961	32x20-6x40	1
		52ZY-W220	2201	25x25-6x40	1
		52A-4	113	32x32-6x40	1
		52A-5	20023	20x29-6x40	1
		52ZY-W205	2165	20x25-6x40	1
		52ZY-W236	101508	40x6-6x40	1
		52B-121	62694	13x6-6x40	1
		52A-32	131	25x16-6x40	1
		52ZY-W186	6898	13x20-6x40	1
		52A-14	45422	18x22-6x40	1
		52A-25	20047	25x6-6x40	1
		52ZY-W176	2072	10x13-6x40	1
		52A-37	139	32x6-6x40	1
		52ZY-W217	122868	25x10-6x40	1
		9011	54222	16x150-6x40	1



## PREMIUM\*\*\* MOUNTED POINTS

ELASTIC for nonferrous metals, PVC, steel and stainless steel



Coordinated light grey bond systems enable the ELASTIC mounted points to be put to both universal use and use tailored to the application. The assortment includes soft elastic points for curved surfaces and medium elastic points for straight surfaces.

Our range also includes fewer elastic points for working at higher speeds and mottling points for mottling surfaces. Maximum operating speed: BE13: 16 m/s; BE15: 20 m/s; BE16: 32 m/s.

Shape	Type no.	Dimension	Specification	PU	
	52ZY	938999	10x20-6x40	C240-BE16	10
		891126	16x20-6x40	C150-BE16	10
		54072	16x30-6x40	C80-BE16	10
		582369	20x20-6x40	C46-BE16	10
		6884	10x20-6x40	C240-BE15	10
		267341	10x20-6x40	C240-BE24	10
		6915	16x20-6x40	C150-BE15	10
		21273	16x30-6x40	C80-BE15	10
		274654	16x30-6x40	C80-BE24	10
		2155	20x20-6x40	C150-BE15	10
		2152	20x20-6x40	C46-BE15	10
		6949	25x20-6x40	C80-BE15	10
		2224	30x30-6x40	C150-BE15	10
		2226	30x30-6x40	C240-BE15	10
		2221	30x30-6x40	C46-BE15	10
		162390	30x30-6x40	C46-BE24	10
		2222	30x30-6x40	C80-BE15	10
	13068	30x30-6x40	C80-BE24	10	
	123432	20x30-6x40	A150-BE24	10	
	52MS	6411	30x30-6x40	C46-BE13	1
		923	30x30-6x40	C46-BE15	1
		6413	40x30-6x40	C46-BE13	1
		925	40x30-6x40	C46-BE15	1
		929	50x30-6x40	C46-BE15	1





## **2.6 TUNGSTEN CARBIDE BURRS FOR STRAIGHT GRINDERS**



## TUNGSTEN CARBIDE BURRS FOR STRAIGHT GRINDERS

Straight grinders are always in high demand when precise results are required on difficult-to-access areas. Their versatile application options make straight grinders a popular tool. In order that there is always a solution at hand for the full spectrum of applications, TYROLIT offers a wide range of PREMIUM quality tungsten carbide burr shapes.

TYROLIT burrs are made from tried-and-tested, high-quality cemented carbide types on the most modern CNC grinding machines. Our tungsten carbide burrs are then used on

a wide range of handheld, pneumatic and electronic machines, as well as on industrial robots. Thanks to their versatility, the cutters can be used on a variety of materials.

## Application recommendation



Performance Level	Specification	Pages	Steel	Stainless steel	NF metals	Cast iron	HSS	Tooth shape
<b>PREMIUM</b> ★★★	MY	118, 119, 120, 121	●	●		●	●	
	MX	118, 119, 120, 121	●	●		●	●	
	MXX	118, 119, 120, 121	●	●		●	●	
	MXC	119, 120	●	●		●	●	
	ALU	121, 122			●			

Items with grey lettering are only available on request.

## Segmentations:

- ALU:** For aluminium machining (standard with 8 cutting edges)
- ALU6:** For aluminium machining (especially coarse with 6 cutting edges)
- MXC:** For cast steel, welding seams, hardened and cured steels (chip breaker)
- MX:** For high-alloyed steels, rust, acid and heat-resistant cast metals and plastics (diamond)
- MXX:** For high-alloyed steels, rust, acid and heat-resistant cast metals and plastics (fine diamond)
- MY:** For cast steel, welding seams, high-strength hardened and unhardened steels (standard)

## Tungsten carbide burr dimensions

16 x 20 – 6 x 40

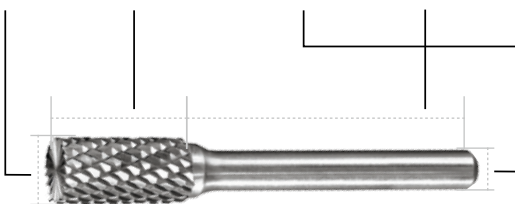



## Shapes



52FLH Flame



52TRE Drop



52KEL Rounded cone



52WRC Ball cylinder



52KSK Conical countersink



52ZYA Cylinder

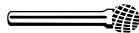

52KUD Ball



52ZYA-S Cylinder with face toothwork



52RBF Tree



52ZYA-R Cylinder with corner radius



52SKM Pointed cone



52SKM-N



52SPG Bullet



52WKN Cone



52RND Grooves

## Areas of application



52FLH Flame



52TRE Drop



52KEL Rounded cone



52WRC Ball cylinder



52KSK Conical countersink



52ZYA Cylinder



52KUD Ball



52ZYA-S Cylinder with face toothwork or as  
52ZYA-R Cylinder with corner radius



52RBF Tree



52SKM Pointed cone  
Combined cone and ball  
cutter



52SPG Bullet



52WKN Cone



52RND Grooves



# Recommended speeds

**Unhardened steel**

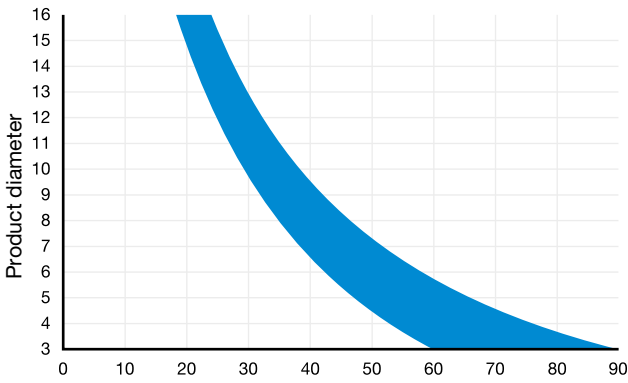

**Ceramics, hardened steels, stainless steels, nickel-based alloy, titanium**

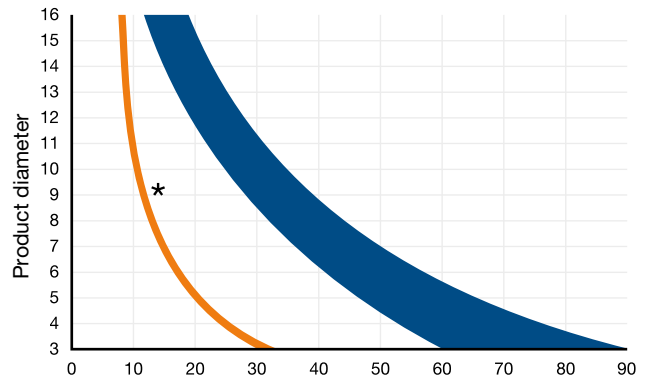

**Soft long-chipping materials, aluminium, fibre-glass-reinforced plastic, plastics, zinc-based alloy**

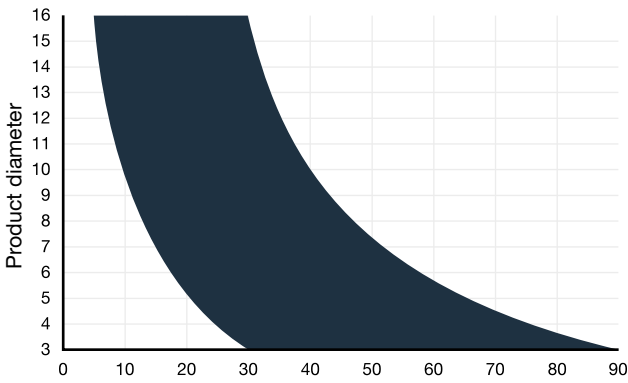

**Brass, cast iron, copper, bronze**

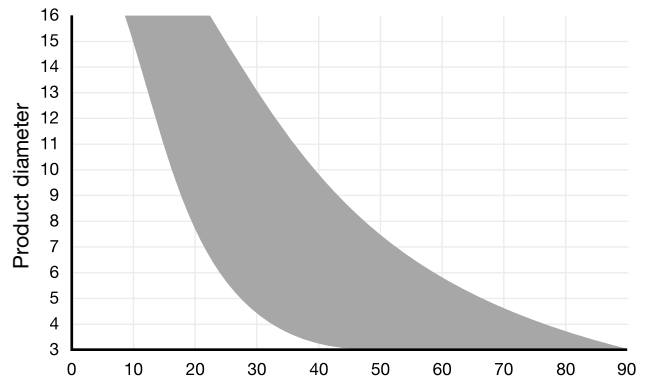











**PREMIUM\*\*\* TUNGSTEN CARBIDE BURRS**









For cast iron, steel and stainless steel

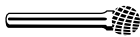

Production of the TYROLIT PREMIUM\*\*\* burrs is performed on modern CNC grinding machines. The result is a highly efficient precision tool that achieves optimum grinding results. With this tungsten carbide burr you can achieve the longest lifetimes when used on practically any material. By choosing the right machine, the correct revolutions per minute and

operating speed, and the appropriate cutting and tooth profile, you will pave the way for PREMIUM results.

	Shape	Type no.	Type no.	Dimension	Specification	PU
		52FLH	765657	3x8-3x38	MX	1
			801351	6x14-6x50	MX	1
			765996	8x19-6x65	MX	1
			768898	12x32-6x77	MX	1
			766046	12x32-8x77	MX	1
		52KEL	766932	3x8-3x38	MX	1
			801354	6x13-3x45	MX	1
			766934	6x16-6x50	MX	1
			902732	8x22-6x69	MX	1
			766068	10x19-6x65	MX	1
			766936	10x27-6x75	MX	1
			768894	12x30-6x75	MX	1
			766072	12x30-8x75	MX	1
			837619	12x30-8x75	MXX	1
			801355	16x33-8x78	MXX	1
		52KSK	769680	10x5-6x55	MY	1
			769683	16x8-6x60	MY	1
		52KUD	766050	3x2.7-3x38	MX	1
			766927	4x3.6-3x45	MX	1
			766051	6x5.4-3x38	MX	1
			768821	6x5.4-6x50	MX	1
			768824	8x7.2-6x52	MX	1
			768828	10x9-6x53	MX	1
			768832	12x10.8-6x55	MX	1
			768833	13x11.7-6x55	MXX	1
			768835	16x14.4-6x60	MX	1
			768834	16x14.4-6x60	MY	1
			768838	16x14.4-8x60	MX	1
		52RBF	766155	3x13-3x38	MX	1
			766156	6x13-3x45	MX	1
			768841	6x16-6x50	MX	1
			902700	8x22-6x67	MX	1

	Shape	Type no.	Dimension	Specification	PU	
		52RBF	768843	10x19-6x65	MX	1
			768846	12x25-6x70	MX	1
			768847	12x25-6x70	MXX	1
			766160	12x25-8x70	MX	1
			766929	16x25-8x70	MX	1
		52SKM	801365	3x11-3x38	MX	1
			902747	3x11-6x38	MXC	1
			766091	3x13-3x38	MX	1
			766092	6x13-3x45	MX	1
			902737	6x13-3x45	MY	1
			768913	6x19-6x50	MX	1
			768912	6x19-6x50	MY	1
			768916	10x16-6x65	MX	1
			910834	10x16-6x65	MXC	1
			766937	12x19-6x65	MX	1
			768919	12x22-6x70	MX	1
			768918	12x22-6x70	MY	1
					52SPG	766139
766140	6x13-3x45	MX				1
768941	6x16-6x50	MX				1
768942	6x16-6x50	MXX				1
768944	10x19-6x65	MX				1
766942	12x19-6x65	MX				1
768948	12x25-6x70	MX				1
902724	12x25-6x70	MXC				1
768949	12x25-6x70	MXX				1
766145	13x25-8x70	MX				1
768951	16x25-6x70	MX				1
766147	16x25-8x70	MX				1
		52TRE				766939
			766150	6x10-3x42	MX	1
			768924	8x13-6x58	MX	1
			768926	10x16-6x60	MX	1
			768929	12x22-6x67	MX	1
			766154	16x25-6x70	MX	1
		52WRC	766126	3x13-3x38	MX	1
			766127	6x13-3x45	MX	1
			768874	6x19-6x50	MX	1
			910766	6x19-6x50	MXC	1
			768873	6x19-6x50	MY	1







**PREMIUM\*\*\* TUNGSTEN CARBIDE BURRS**

For cast iron, steel and stainless steel













Production of the TYROLIT PREMIUM\*\*\* burrs is performed on modern CNC grinding machines. The result is a highly efficient precision tool that achieves optimum grinding results. With this tungsten carbide burr you can achieve the longest lifetimes when used on practically any material. By choosing the right machine, the correct revolutions per minute and

operating speed, and the appropriate cutting and tooth profile, you will pave the way for PREMIUM results.

	Shape	Type no.	Dimension	Specification	PU	
		52WRC	768878	8x19-6x65	MX	1
		768880	8x19-6x65	MXX	1	
		768877	8x19-6x65	MY	1	
		768881	10x19-6x65	MX	1	
		766130	10x19-6x65	MY	1	
		766930	12x25-6x70	MX	1	
		766133	12x25-6x70	MXX	1	
		766131	12x25-6x70	MY	1	
		768887	12x25-8x70	MX	1	
		768888	12x25-8x70	MXX	1	
		801349	13x19-6x65	MX	1	
		768891	16x25-6x70	MX	1	
		766134	16x25-8x70	MX	1	
				52ZYA	766099	3x13-3x38
766944	4x13-4x50			MX	1	
766100	6x13-3x45			MX	1	
768747	6x19-6x50			MX	1	
768750	8x19-6x65			MX	1	
766108	10x19-6x65			MX	1	
768752	10x19-6x65			MXX	1	
766945	12x25-6x70			MX	1	
801348	13x19-6x65			MX	1	
768754	16x25-6x70			MX	1	
766111	16x25-8x70			MX	1	
		52ZYA-S	766112	3x13-3x38	MX	1
		902665	3x13-3x38	MY	1	
		766113	6x13-3x45	MX	1	
		768710	6x19-6x50	MX	1	
		902668	6x19-6x50	MXC	1	
		768712	8x19-6x65	MX	1	
		766115	8x19-6x65	MY	1	
		766116	10x19-6x65	MX	1	
		766120	10x19-6x65	MY	1	
		766949	12x19-6x65	MX	1	



	Shape	Type no.	Dimension	Specification	PU	
		52ZYA-S	766121	12x25-6x70	MX	1
			766117	12x25-6x70	MXX	1
			768718	12x25-8x70	MX	1
			768721	16x25-6x70	MX	1
			766119	16x25-8x70	MX	1
		52RND	801529	10x1.6-3x34	MY	1
			801530	12x2.6-6x48	MY	1
			801531	25x5.2-8x50	MY	1
		52ZYA-R	20553	3x13-3x38	MX	1
			20555	6x16-6x50	MX	1
			20557	8x19-6x65	MX	1
			20565	10x19-6x65	MX	1
			20587	12x25-6x70	MX	1
			20590	16x25-6x70	MX	1
		52SKM-N	20487	12x25-6x70	MY	1
		52KUD-N	34022392	12x20-6x63	MX	1

**PREMIUM\*\*\* TUNGSTEN CARBIDE BURRS**









For nonferrous metals



Production of the TYROLIT PREMIUM\*\*\* burrs is performed on modern CNC grinding machines. The result is a highly efficient precision tool that has been specially developed for use on nonferrous metals. With these products you can achieve the longest lifetimes.

By choosing the right machine, the correct revolutions per minute and

operating speed, and the appropriate cutting and tooth profile, you will pave the way for PREMIUM results.

	Shape	Type no.	Dimension	Specification	PU	
		52KEL	766935	10x27-6x75	ALU	1
			768896	12x30-6x75	ALU	1
			801527	16x33-8x78	ALU	1
		52RBF	768845	10x19-6x65	ALU	1
			768848	12x25-6x70	ALU	1
			801524	16x25-8x70	ALU	1
		52WRC	768884	10x19-6x65	ALU	1
			768885	12x25-6x70	ALU	1
			801528	16x25-8x70	ALU	1
		52ZYA	806824	10x19-6x65	ALU	1
			806826	12x25-6x70	ALU	1

## PREMIUM★★★ TUNGSTEN CARBIDE BURRS



For nonferrous metals



Production of the TYROLIT PREMIUM\*\*\* burrs is performed on modern CNC grinding machines. The result is a highly efficient precision tool that has been specially developed for use on nonferrous metals. With these products you can achieve the longest lifetimes.

By choosing the right machine, the correct revolutions per minute and

operating speed, and the appropriate cutting and tooth profile, you will pave the way for PREMIUM results.

	Shape	Type no.	Dimension	Specification	PU	
		52ZYA-S	768715	10x19-6x65	ALU	1
			768717	12x25-6x70	ALU	1

## PREMIUM★★★ TUNGSTEN CARBIDE BURR SET

For cast iron, steel and stainless steel



The PREMIUM\*\*\* tungsten carbide burr set contains common burrs for machining cast iron, steel and stainless steel materials. Production on CNC machines results in a highly efficient precision tool that achieves optimum grinding results. With this tungsten carbide burr you can achieve the longest lifetimes when used on practically any material.

By choosing the right machine, the correct revolutions per minute and

operating speed, and the appropriate cutting and tooth profile, you will pave the way for PREMIUM results.

	Type no.	Shape	Dimension	Specification	PU
	822725	52WRC	12x25		1
		52KEL	12x30	Cemented carbide milling point set: 5 parts	1
		52RBF	12x25	with shaft S6 x 40	1
		52SPG	12x25		1
		52KUD	12x11.7		1
845416		52FLH	8x19		1
		52KEL	10x19		1
		52SPG	6x16		1
		52SPG	10x19		1
		52TRE	8x13	1 cemented carbide	1
		52WRC	6x19	milling point set: 10	1
				parts with shaft S6 x 40	1
		52WRC	8x19		1
		52WRC	10x19		1
		52ZYA	8x19		1
52ZYA-S	10x19		1		



Type no.	Shape	Dimension	Specification	PU
822718	52KEL	12x30		1
	52WRC	12x25		1
	52SPG	12x25		1
	52SKM	12x22		1
	52KUD	12x11.7	Cemented carbide milling point set: 5 parts with shaft S6 x 40	1
	52ZYA-S	10x19		1
	52WRC	8x19		1
	52RBF	10x19		1
	52SPG	6x16		1
	52KUD	8x7.2		1
	34022430	52SKM-N	12x25	
52KUD-N		12x20	Cemented carbide mill- ing point set: 5 parts with shaft S6 x 40	1
52ZYA-R		12x25		1
52ZYA-R		10x19		1
52ZYA-R		6x16		1

### PREMIUM\*\*\* TUNGSTEN CARBIDE BURR SET

For nonferrous metals



The PREMIUM\*\*\* tungsten carbide burr set contains common burrs for nonferrous metal applications. Production on CNC machines results in a highly efficient precision tool that achieves optimum grinding results. With this tungsten carbide burr you can achieve the longest lifetimes when used on practically any material.

By choosing the right machine, the correct revolutions per minute and

operating speed, and the appropriate cutting and tooth profile, you will pave the way for PREMIUM results.



Type no.	Shape	Dimension	Specification	PU
822728	52WRC	10x19		1
	52WRC	12x25	Cemented carbide mill- ing point set: 5 parts with shaft S6 x 40	1
	52RBF	10x19		1
	52RBF	12x25		1
	52KEL	12x30		1





# CATALOGUE 18

## BRUSHES

<b>Brushes information</b>	126
Explanation of labels	126
Wire types	126
Machine pictograms	127
Specification	127
Application	127
<b>Angle grinder</b>	129
3.1 Brushes	130
SHIELD brushes	133
Cup brushes	134
Tapered brushes	136
Round brushes	137
<b>Straight grinder</b>	139
3.2 Brushes	140
Wire brushes	143
Shaft mounted cup brushes	145
Shaft mounted round brushes	147
<b>Floorstanding grinder</b>	151
3.3 Round brushes	152
<b>Hand-guided grinding</b>	157
3.4 Hand brushes	158





# SPECIFIC INFORMATION

## TOOL BRUSHES

### Brushes product label



### Wire types

	Abbreviation	Description	Application		Abbreviation	Description	Application
	DW	Knotted wire	Suitable for soft materials such as nonferrous metals, sensitive surfaces and slight impurities		DG	Straight wire	For cleaning workpieces with hand tools
	DZ	Twisted wire	Suitable for heavy work, severe dirt and removing layers of paint or varnish		DE	Wire with plastic	Suitable for accurate work as splaying of wire is prevented; particularly helpful in automotive repairs
	DK	Wire with grain	Suitable for deburring gears, valve parts, cutting edges of aluminium profiles and pipes				

## Pictograms Machines



Angle grinder



Straight grinder



Floorstanding grinder



Hand-guided grinding

## Specification

**6T DZ SH 0,5**

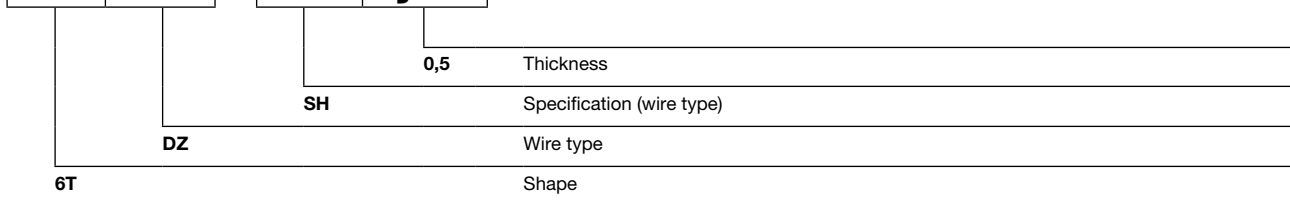

**S** Steel wire



**E** Stainless steel wire



**M** Brass wire

**SH** Hardened steel wire

**EA** Stainless, acid-resistant steel wire

**A** Wire with aluminium oxide grain

**SZ** Hardened and tough steel wire

**C** Wire with silicon carbide grain

**SM** Brassed steel wire

## Pressure

Brushes need only light pressure, as the wire tips do all the work. Heavy pressure does not improve the brushing result. Heavy pressure shortens the lifetime and requires more force.

Excessive pressure

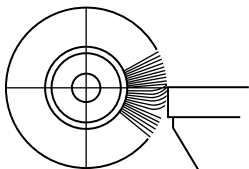

Correct pressure

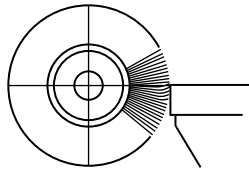







A low-angle, blue-tinted photograph of a worker in a denim shirt and overalls. The worker is on the left side of the frame, looking towards the right. In the background, a large industrial machine is processing a large metal plate. The scene is set in a factory with a high ceiling and various pipes and structures. The overall atmosphere is industrial and focused.

## **3.1 BRUSHES** ANGLE GRINDER



## BRUSHES FOR ANGLE GRINDERS

Working with an angle grinder is one of the most important processes in the trade and industrial sectors for processing all types of metals. TYROLIT offers a comprehensive assortment of brushes for angle grinders.

Brushes are generally very versatile and can be used for a wide range of applications such as deburring, cleaning welding seams or the surfaces of virtually any material.

The wide assortment of TYROLIT tool brushes has the right shape, wire type and specification for every job.

### Application recommendations



Performance level	Specification	Pages	Steel	Stainless steel	NF-metals
<b>PREMIUM★★★</b>	S...	133, 134, 136, 137	●		
	SH...	134, 135, 136, 137	●		
	SZ...	135	●		
	E... INOX	134, 135, 136, 137		●	
	M...	136			●
	SM..	133	●		

Items with grey lettering are only available on request.

## Shapes



**11TDW** cup brush

For removing rust, paint and dirt and for smooth finishing



**11TDZ** cup brush

Ideal for preparing surfaces before painting, removing slag, rust, scale and concrete residues



**6TDZ** cup brush

For heavy work and removal of rust, paint, dirt or scale



**28KDW** Tapered brush

For hard-to-reach areas, for removal of rust, paint, dirt and for smooth finishing



**28KDZ** Tapered brush

For hard-to-reach areas, for removal of slag, rust and scale

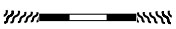

**1RDZ** Round brush

For welding and for removal of scale and paint

## Dimensions

### Cup and tapered brushes

80 x 25 x M14



### Round brushes

115 x 11 x 23 x 22,2

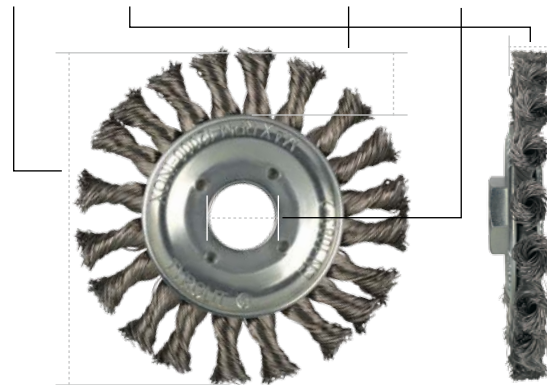



## Maximum speeds

The max. rpm is the speed at which the brushes can be safely used. This must not be exceeded. In most cases it is advantageous to use a lower speed in order to achieve better results.

**Caution:** Before each use, compare the speeds of the tool and of the machine.

Ø	60	65	75	80	90	100	115	125	150	178	200
Round brush, twisted						11,000	11,000	9,000	9,000	8,500	6,500
Cup brush, knotted	11,000		11,000	9,000				6,500	6,500		
Cup brush, twisted, shape 11		11,000	11,000	11,000	11,000	6-8,500		6,500			
Cup brush, twisted, shape 6				6-8,500		6-8,500		6,500			
Tapered brush, knotted						11,000					
Tapered brush, twisted						11,000	11,000				

## Optimum peripheral speed

Application	Peripheral speed in m/s							
	5	15	20	25	30	35	40	45
Deburring								
Processing of welding seams								
Descaling								
Polishing								
Processing of plastic								
Cleaning								
Rust removal								



# PREMIUM★★★ SHIELD CUP BRUSHES FOR STEEL

## + Enhanced user safety

The protective plastic flaps provide protection from undesired wire breakages and dust.

## + Broad assortment

SHIELD cup brushes from TYROLIT are available in various shapes and wire types.



## + No restriction

The protection is transparent and therefore makes it easier to have a clear view of the surface being worked on. Even difficult-to-access areas are no longer a challenge thanks to the flexibility and pliability of the plastic.

With SHIELD cup brushes, TYROLIT offers a protective coating against dust and wire breakages combined with user-friendly use. The transparent protection allows the operator an unrestricted view of the workpiece even when performing edge and cor-

ner grinding. In addition, the plastic flaps offer a high level of flexibility, making it possible to machine difficult-to-reach places.

SHIELD brushes are available in various designs and wire types, and

offer the highest safety levels when working on steel. Applications. Our products are also frequently used to clean welding seams.

## PREMIUM★★★ SHIELD CUP BRUSHES for steel



	Shape	Type no.	Dimension	Specification	PU	Max. RPM	
		11TDW 34023780	75x20xM14-2	SM0,3	1	13.000	
		11TDZ 34023778	65x20xM14-2	S0,5	1	15.000	
		6TDW	34023827	80x30xM14-2	SM0,3	1	8.500
			34023828	100x30xM14-2	SM0,3	1	8.500
		6TDZ	34023823	80x25xM14-2	S0,5	1	8.500
			34023824	100x25xM14-2	S0,5	1	8.500
	28KDW	34023819	100x20xM14-2	SM0,3	1	13.000	
		28KDZ 34023817	100x20xM14-2	S0,5	1	15.000	

**PREMIUM★★★ SHIELD CUP BRUSHES**

For stainless steel



With SHIELD cup brushes, TYROLIT offers a protective coating against dust and wire breakages combined with user-friendly use. SHIELD brushes are available in various designs and wire types, and offer the highest safety levels when working on steel. Applications. Our products are also frequently used to clean welding seams.

The transparent protection allows the operator an unrestricted view of the

workpiece even when performing edge and corner grinding. In addition, the plastic flaps offer a high level of flexibility, making it possible to machine difficult-to-reach places.

	Shape	Type no.	Dimension	Specification	PU	Max. RPM
		11TDW 34023812	75x20xM14-2	E0,3INOX	1	13,000
		11TDZ 34023813	65x20xM14-2	E0,5INOX	1	15,000
		6TDW 34023829	80x30xM14-2	E0,3INOX	1	8,500
		34023830	100x30xM14-2	E0,3INOX	1	8,500
		6TDZ 34023825	80x25xM14-2	E0,5INOX	1	8,500
		34023826	100x25xM14-2	E0,5INOX	1	8,500
		28KDW 34023822	100x20xM14-2	E0,3INOX	1	13,000
	28KDZ 34023818	100x20xM14-2	E0,5INOX	1	15,000	

**PREMIUM★★★ CUP BRUSHES**



For steel



Wire brushes are universal tools for all applications. Cup brushes in particular are among the most commonly-used brush tools. TYROLIT will provide you with the appropriate wire brush for your application depending on the wire type. Twisted wire brushes are used for preparing surfaces and removing rust, scales and concrete residue.

Wire brushes with knotted wire can also be used to remove rust and paint, as well as for fine grinding. Our products are also frequently used to clean welding seams.

	Shape	Type no.	Dimension	Specification	PU	Max. RPM	
		11TDW 896157	60x16xM14	S0,3	1	11,000	
		896158	60x16xM14	S0,5	1	11,000	
		896160	75x20xM14	S0,3	1	9,000	
		896161	75x20xM14	S0,5	1	9,000	
		896162	100x30x22,2	S0,3	1	8,500	
		896163	100x30x22,2	S0,5	1	8,500	
		896164	100x30xM14	S0,3	1	8,500	
		896165	100x30xM14	S0,5	1	8,500	
		896250	125x35xM14	S0,3	1	6,500	
		896252	125x35xM14	S0,5	1	6,500	
		896253	150x55xM14	S0,3	1	6,500	
		896255	150x55xM14	S0,5	1	6,500	
			11TDZ 829292	80x35xM14	SH0,5	1	7,500
			829293	100x35xM14	SH0,5	1	7,500
			890868	100x45xM14	SZ0,35	1	7,500

	Shape	Type no.	Dimension	Specification	PU	Max. RPM	
		6TDZ	890860	65x20xM14	SH0,35	1	12,000
			890862	65x20xM14	SH0,5	1	12,000
			890863	80x25xM14	SH0,35	1	8,500
			890864	80x25xM14	SH0,5	1	8,500
			890865	100x25x22,2	SH0,35	1	8,500
			34042518	100x25x22,2	SH0,5	1	8,500
			890866	100x25xM14	SH0,35	1	8,500
			896289	100x25xM14	SH0,5	1	8,500
			896291	120x25xM14	SH0,35	1	6,500
			896290	120x25xM14	SH0,5	1	6,500
			896293	140x25xM14	SH0,35	1	5,500
			896292	140x25xM14	SH0,5	1	5,500



**PREMIUM★★★ CUP BRUSHES**

For stainless steel



Wire brushes are universal tools for all applications. Cup brushes in particular are among the most commonly-used brush tools. TYROLIT will provide you with the appropriate wire brush for your application depending on the wire type. Twisted wire brushes are used for preparing surfaces and removing rust, scales and concrete residue.

Wire brushes with knotted wire can also be used to remove rust and paint, as well as for fine grinding. Our products are also frequently used to clean welding seams.

	Shape	Type no.	Dimension	Specification	PU	Max. RPM			
		11TDW	896167	60x16xM14	E0,3INOX	1	11,000		
			896169	60x16xM14	E0,5INOX	1	11,000		
			896170	75x20xM14	E0,3INOX	1	9,000		
			896171	75x20xM14	E0,5INOX	1	9,000		
			896172	100x30x22,2	E0,3INOX	1	8,500		
			896173	100x30x22,2	E0,5INOX	1	8,500		
			896174	100x30xM14	E0,3INOX	1	8,500		
			896175	100x30xM14	E0,5INOX	1	8,500		
				6TDZ	890851	65x20xM14	E0,35INOX	1	12,000
					890852	65x20xM14	E0,5INOX	1	12,000
					34042519	80x25xM14	E0,35INOX	1	8,500
					890853	80x25x22,2	E0,5INOX	1	8,500
					890854	80x25xM14	E0,5INOX	1	8,500
					890855	100x25x22,2	E0,35INOX	1	8,500
					890856	100x25x22,2	E0,5INOX	1	8,500
					890858	100x25xM14	E0,35INOX	1	8,500
					890859	100x25xM14	E0,5INOX	1	8,500



**PREMIUM\*\*\* CUP BRUSHES**

For nonferrous metals



PREMIUM\*\*\* cup brushes with brass wire are ideal for machining nonferrous metals. Due to its hardness, the brass wire achieves the best results on the brass workpiece. Their knotted wire design enables them to easily remove paint, dirt and varnish.

They are ideal for fine work and thus make working on nonferrous metals easier.

	Shape	Type no.	Dimension	Specification	PU	Max. RPM	
		11TDW	896943	60x16xM14	M0,3	1	11,000
			34042515	80x25xM14	M0,3	1	8,500
			34042517	100x30xM14	M0,3	1	8,500



**PREMIUM\*\*\* TAPERED BRUSHES**

For steel



These PREMIUM\*\*\* wire brushes are particularly suitable for machining hard-to-reach parts due to their shape. TYROLIT will provide you with the appropriate wire brush for your application depending on the wire type. Twisted wire brushes are used for preparing surfaces and removing rust, scales and concrete residue.

Wire brushes with knotted wire can also be used to remove rust and paint, as well as for fine grinding. Our products are also frequently used to clean welding seams.

	Shape	Type no.	Dimension	Specification	PU	Max. RPM	
		28KDW	829306	100x20xM14	S0,3	1	12,500
		28KDZ	896294	100x20xM14	SH0,35	1	12,500
			894595	100x20xM14	SH0,5	1	12,500
			894598	115x27.5xM14	SH0,5	1	12,500
		28KDZR	34042520	115x27.5xM14	SH0,35	1	12,500



**PREMIUM\*\*\* TAPERED BRUSHES**

For stainless steel

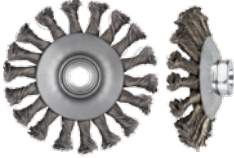

These PREMIUM\*\*\* wire brushes are particularly suitable for machining hard-to-reach parts due to their shape. TYROLIT will provide you with the appropriate wire brush for your application depending on the wire type. Twisted wire brushes are used for preparing surfaces and removing rust, scales and concrete residue.

Wire brushes with knotted wire can also be used to remove rust and paint, as well as for fine grinding. Our products are also frequently used to clean welding seams.

	Shape	Type no.	Dimension	Specification	PU	Max. RPM	
		28KDW	896260	100x20xM14	E0,3INOX	1	12,500
		28KDZ	894602	100x20xM14	E0,5INOX	1	12,500
			938642	115x27.5xM14	E0,35INOX	1	12,500
			938646	115x27.5xM14	E0,5INOX	1	12,500
		28KDZR	829330	100x20xM14	E0,35INOX	1	12,500



**PREMIUM\*\*\* ROUND BRUSHES**

For steel



The PREMIUM\*\*\* round brushes are ideal for welding. TYROLIT will provide you with the appropriate wire brush for your application depending on the wire type. Twisted wire brushes are used for preparing surfaces and removing rust, scales and concrete residue.

Wire brushes with knotted wire can also be used to remove rust and paint,

as well as for fine grinding. Our products are also frequently used to clean welding seams.

	Shape	Type no.	Dimension	Specification	PU	Max. RPM	
		1RDZ	943976	100x11x22x22.2	SH0,5	1	11,000
		890618	100x11x22xM14	SH0,5	1	11,000	
		310303	115x11x23x22.2	SH0,35	1	11,000	
		894085	115x11x23x22.2	SH0,5	1	11,000	
		960324	115x11x23xM14	S0,35	1	11,000	
		938680	115x11x23xM14	SH0,5	1	11,000	
		903406	125x12x25x22.2	SH0,35	1	12,000	
		947205	125x12x25x22.2	SH0,5	1	12,000	
		34042522	125x12x25xM14	SH0,35	1	12,000	
		603818	125x12x25xM14	SH0,5	1	12,000	
		34042525	178x15x44xM14	SH0,35	1	9,000	
		34042524	178x15x44xM14	SH0,5	1	9,000	
		829026	178x13x38x22.2	SH0,5	1	9,000	

**PREMIUM\*\*\* ROUND BRUSHES**

For stainless steel



The PREMIUM\*\*\* round brushes are ideal for welding. TYROLIT will provide you with the appropriate wire brush for your application depending on the wire type. Twisted wire brushes are used for preparing surfaces and removing rust, scales and concrete residue.

Wire brushes with knotted wire can also be used to remove rust and paint,

as well as for fine grinding. Our products are also frequently used to clean welding seams.

	Shape	Type no.	Dimension	Specification	PU	Max. RPM	
		1RDZ	890623	100x11x22xM14	E0,5INOX	1	11,000
		310305	115x11x23x22.2	E0,35INOX	1	11,000	
		890608	115x11x23x22.2	E0,5INOX	1	11,000	
		16422	115x11x23xM14	E0,35INOX	1	11,000	
		890626	115x11x23xM14	E0,5INOX	1	11,000	
		890635	125x12x25x22.2	E0,35INOX	1	12,000	
		34042526	125x12x25x22.2	E0,5INOX	1	12,000	
		34042528	125x12x25xM14	E0,35INOX	1	12,000	
		34042527	125x12x25xM14	E0,5INOX	1	12,000	
		16425	178x15x44xM14	E0,35INOX	1	9,000	
		942005	178x15x35x22.2	E0,5INOX	1	9,000	
		16427	178x15x44xM14	E0,5INOX	1	9,000	







## **3.2 BRUSHES**

### STRAIGHT GRINDER



## BRUSHES FOR STRAIGHT GRINDERS

Straight grinders are needed when precise results are required in hard-to-reach areas such as the inside of pipes. Their versatility makes them a popular tool.

That's why TYROLIT offers a comprehensive assortment of cup, round and wire brushes which can also be used on other machines, such as drilling machines.

The range of applications is very wide. Shaft mounted brushes are used for surface treatment such as cleaning rust, deburring, texturing and removing layers such as paint or rubber.



## Application recommendations



Performance level	Specification	Pages	Steel	Stainless steel	NF-metals	All in one
<b>PREMIUM***</b>	S...	143, 145, 147	●			
	SH...	147	●			
	SZ...	143	●			
	E... INOX	144, 146, 148		●		
	EA... INOX	148		●		
	M...	144, 146, 148			●	
	SM...	143	●			
	C...	145, 147, 149				●

Items with grey lettering are only available on request.

## Shapes



**52TDW** Cup brushes

Suitable for cleaning work, such as removing paint or rust or for deburring



**52RDW** Round brushes

For removing rust, cleaning, smoothing, polishing, matting and roughening

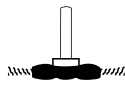

**52RDZ** Round brushes

Designed for welding and removing scale and paint



**52RDK** Round brushes

For matting and glazing, coated with grain



**52PDE** Wire brushes

Suitable for roughening, deburring, descaling and cleaning. The plastic coating ensures a long tool life

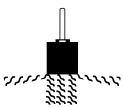

**52PDZ** Wire brushes

Suitable for roughening, deburring, descaling, matting and cleaning. These wire brushes are characterised by their high level of flexibility. The wire brush opens due to centrifugal force. They are also particularly suitable for cleaning the inside of pipes.

## Dimensions

### Wire brushes

12 x 20 – 6 x 60

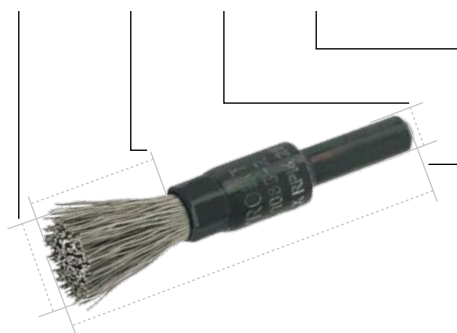

### Shaft mounted cup brushes

50 x 10 x 20 – 6 x 30

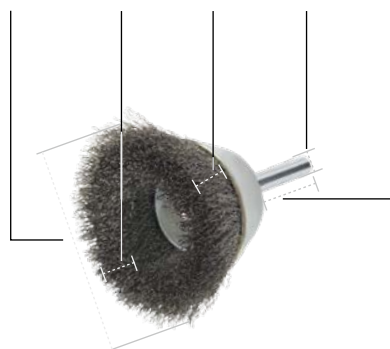

### Shaft mounted round brushes

70 x 6 x 15 – 6 x 30

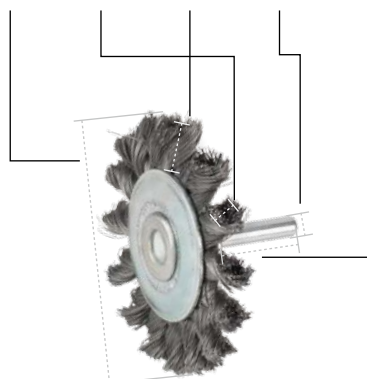

## Optimum peripheral speed

Application	Peripheral speed in m/s							
	5	15	20	25	30	35	40	45
Deburring								
Processing of welding seams								
Descaling								
Polishing								
Processing of plastic								
Cleaning								
Rust removal								

**PREMIUM\*\*\* WIRE BRUSHES**

For steel



Wire brushes are ideal for machining hard-to-reach parts. With this product you will obtain a tool that can be used on both straight grinders and drilling machines. Twisted wire brushes are suitable for roughening, deburring, descaling, matting and cleaning. These wire brushes are characterised by their high level of flexibility. The wire brush opens due to centrifugal force. They are also particularly suitable for cleaning the inside of pipes. Knotted

wire brushes are suitable for roughening, deburring, descaling, matting and cleaning. Also to remove burr, rust, rubber and other impurities in difficult-to-reach areas. Wire brushes with plastic achieve a longer lifetime.

	Shape	Type no.	Dimension	Specification	PU	Max. RPM	
		52PDW	903431	12x20-6x60	S0,2	25	20,000
		890719	12x20-6x60	S0,3	25	20,000	
		903432	12x20-6x60	S0,5	25	20,000	
		34043179	17x22-6x65	S0,2	25	18,000	
		890721	17x22-6x65	S0,3	25	18,000	
		52679	17x22-6x65	S0,5	25	18,000	
		903429	24x25-6x68	S0,2	25	18,000	
		903430	24x25-6x68	S0,3	25	18,000	
		890722	24x25-6x68	S0,5	25	18,000	
		58293	30x25-6x68	S0,2	25	15,000	
		19012	30x25-6x68	S0,3	25	15,000	
		890723	30x25-6x68	S0,5	25	15,000	
	52PDZ	34043520	19x28-6x68	SZ0,25	25	20,000	
		903357	19x28-6x68	SZ0,35	25	20,000	
		34043541	19x28-6x68	SZ0,5	25	20,000	
		34043542	22x28-6x68	SZ0,25	25	20,000	
		34043543	22x28-6x68	SZ0,35	25	20,000	
		34043544	22x28-6x68	SZ0,5	25	20,000	
		939968	28x28-6x68	SZ0,25	25	20,000	
		34043545	28x28-6x68	SZ0,35	25	20,000	
		936422	28x28-6x68	SZ0,5	25	20,000	
	52PDE	890649	10x25-6x60	SM0,3	25	20,000	
		34043180	15x25-6x65	SM0,3	25	15,000	
		890650	22x25-6x68	SM0,3	25	13,000	
		34043181	28x25-6x68	SM0,3	25	13,000	

**PREMIUM\*\*\* WIRE BRUSHES**

For stainless steel



Wire brushes are ideal for machining hard-to-reach parts. With this product you will obtain a tool that can be used on both straight grinders and drilling machines. Twisted wire brushes are suitable for roughening, deburring, descaling, matting and cleaning. These wire brushes are characterised by their high level of flexibility. The wire brush opens due to centrifugal force. They are also particularly suitable for cleaning the inside of pipes. Knotted

wire brushes are suitable for roughening, deburring, descaling, matting and cleaning. Also to remove burr, rust, rubber and other impurities in difficult-to-reach areas.

	Shape	Type no.	Dimension	Specification	PU	Max. RPM	
		52PDW	897357	12x20-6x60	E0,3INOX	25	20,000
			890707	17x22-6x65	E0,3INOX	25	18,000
			890709	24x25-6x68	E0,3INOX	25	18,000
			903340	30x25-6x68	E0,3INOX	25	15,000
		52PDZ	890652	19x28-6x68	E0,25INOX	25	20,000
			890654	19x28-6x68	E0,35INOX	25	20,000
			890653	22x28-6x68	E0,25INOX	25	20,000
			890655	22x28-6x68	E0,35INOX	25	20,000
			934433	28x28-6x68	E0,25INOX	25	20,000
			16746	28x28-6x68	E0,35INOX	25	20,000

**PREMIUM\*\*\* WIRE BRUSHES**

For nonferrous metals



Wire brushes are ideal for machining hard-to-reach parts. With this product you will obtain a tool that can be used on both straight grinders and drilling machines. They are also particularly suitable for cleaning the inside of pipes.

Knotted wire brushes are suitable for roughening, deburring, descaling, matting and cleaning. Also to remove burr, rust, rubber and other impurities in difficult-to-reach areas.

	Shape	Type no.	Dimension	Specification	PU	Max. RPM	
		52PDW	890658	12x20-6x60	M0,2	25	20,000
			903343	12x20-6x60	M0,3	25	20,000
			890708	17x22-6x65	M0,2	25	18,000
			903350	17x22-6x65	M0,3	25	18,000
			890717	24x25-6x68	M0,3	25	18,000
			890718	30x25-6x68	M0,3	25	15,000



**PREMIUM★★★ WIRE BRUSHES**

For universal use



Wire brushes are ideal for machining hard-to-reach parts. With this product you will obtain a tool that can be used on both straight grinders and drilling machines. They are also particularly suitable for cleaning the inside of pipes.

Wire brushes with silicon carbide are very hard and thus enable very

high stock removal rates. Their use includes deburring work on various workpieces made of practically any material, such as steel, aluminium, stainless steel, copper, brass, etc. In addition, silicon carbide is used for wood structuring.

	Shape	Type no.	Dimension	Specification	PU	Max. RPM	
		52PDK	34043547	17x22-6x65	C180	25	18,000
			34043548	24x25-6x68	C120	25	18,000
			34043549	24x25-6x68	C180	25	18,000
			34043550	24x25-6x68	C320	25	18,000
			34043552	30x25-6x68	C180	25	15,000

**PREMIUM★★★ SHAFT MOUNTED CUP BRUSHES**

For steel



Shaft mounted cup brushes are ideal for machining hard-to-reach parts. With this product you will obtain a tool that can be used on both straight grinders and drilling machines.

Knotted shaft mounted cup brushes are suitable for cleaning work, such as removing paint, rust, scale, crust, or deburring.

	Shape	Type no.	Dimension	Specification	PU	Max. RPM	
		52TDW	890753	40x10x15-6x30	S0,2	25	10,500
			890756	40x10x15-6x30	S0,3	25	10,500
			34043171	50x10x20-6x30	S0,2	25	10,500
			903359	50x10x20-6x30	S0,3	25	10,500
			903427	50x50x20-6x30	S0,2	25	10,500
			903428	50x50x20-6x30	S0,3	25	10,500
			890764	60x15x20-6x30	S0,2	25	4,500
			890763	60x15x20-6x30	S0,3	25	4,500
			890765	60x60x20-6x30	S0,2	25	4,500
			890766	60x60x20-6x30	S0,3	25	4,500
			890776	70x15x25-6x30	S0,2	25	4,500
			890774	70x15x25-6x30	S0,3	25	4,500
			890777	70x70x25-6x30	S0,2	25	4,500
			890778	70x70x25-6x30	S0,3	25	4,500

**PREMIUM★★★ SHAFT MOUNTED CUP BRUSHES**

For stainless steel



Shaft mounted cup brushes are ideal for machining hard-to-reach parts. With this product you will obtain a tool that can be used on both straight grinders and drilling machines.

Knotted shaft mounted cup brushes are suitable for cleaning work, such as removing paint, rust, scale, crust, or deburring.

	Shape	Type no.	Dimension	Specification	PU	Max. RPM
		52TDW				
		890757	40x10x15-6x30	E0,2INOX	25	10,500
		890758	40x10x15-6x30	E0,3INOX	25	10,500
		34038259	50x10x20-6x30	E0,2INOX	25	10,500
		903877	50x10x20-6x30	E0,3INOX	25	10,500
		34038260	50x50x20-6x30	E0,2INOX	25	10,500
		903878	50x50x20-6x30	E0,3INOX	25	10,500
		890762	60x15x20-6x30	E0,2INOX	25	4,500
		890761	60x15x20-6x30	E0,3INOX	25	4,500
		890768	60x60x20-6x30	E0,2INOX	25	4,500
		890769	60x60x20-6x30	E0,3INOX	25	4,500
		890772	70x15x25-6x30	E0,2INOX	25	4,500
		890771	70x15x25-6x30	E0,3INOX	25	4,500
		890779	70x70x25-6x30	E0,2INOX	25	4,500
		890780	70x70x25-6x30	E0,3INOX	25	4,500

**PREMIUM★★★ SHAFT MOUNTED CUP BRUSHES**

For nonferrous metals



Shaft mounted cup brushes are ideal for machining hard-to-reach parts. With this product you will obtain a tool that can be used on both straight grinders and drilling machines.

Knotted shaft mounted cup brushes are suitable for cleaning work, such as removing paint, rust, scale, crust, or deburring.

	Shape	Type no.	Dimension	Specification	PU	Max. RPM
		52TDW				
		34043172	40x10x15-6x30	M0,3	25	10,500
		199649	50x10x20-6x30	M0,2	25	10,500
		23470	50x10x20-6x30	M0,3	25	10,500
		34043173	50x50x20-6x30	M0,3	25	10,500
		23469	60x15x20-6x30	M0,3	25	4,500
		34043174	60x60x20-6x30	M0,3	25	4,500
		23471	70x15x25-6x30	M0,3	25	4,500
		34043175	70x70x25-6x30	M0,3	25	4,500



**PREMIUM★★★ SHAFT MOUNTED CUP BRUSHES**

For universal use



Shaft mounted cup brushes are ideal for machining hard-to-reach parts. With this product you will obtain a tool that can be used on both straight grinders and drilling machines. Shaft mounted cup brushes with silicon carbide are very hard and thus enable

very high stock removal rates. Their use includes deburring work on various workpieces made of practically any material, such as steel, aluminium, stainless steel, copper, brass, etc. In addition, silicon carbide is used for wood structuring.

	Shape	Type no.	Dimension	Specification	PU	Max. RPM	
		52TDK	34043177	50x10x20-6x30	C180	25	10,500
			34043178	60x15x20-6x30	C180	25	4,500
			34043546	70x15x25-6x30	C180	25	4,500



**PREMIUM★★★ SHAFT MOUNTED ROUND BRUSHES**

For steel



Shaft mounted round brushes are ideal for machining hard-to-reach parts. With this product you will obtain a tool that can be used on both straight grinders and drilling machines. Knotted wire brushes are suitable for removing rust, cleaning, smoothing, polishing, matting and roughening.

Twisted shaft mounted round brushes are designed for welding and removing scale and paint.

	Shape	Type no.	Dimension	Specification	PU	Max. RPM	
		52RDW	890840	20x4x3-6x30	S0,2	25	20,000
			890841	30x6x6.5-6x30	S0,2	25	20,000
			890842	40x9x9-6x30	S0,2	25	18,000
			890843	40x9x9-6x30	S0,3	25	18,000
			903421	50x15x12.5-6x30	S0,15	25	15,000
			890844	50x15x12.5-6x30	S0,2	25	15,000
			890845	50x15x12.5-6x30	S0,3	25	15,000
			34043554	50x15x12.5-6x30	S0,5	25	15,000
			890846	60x10x17.5-6x30	S0,3	25	15,000
			903422	60x15x17.5-6x30	S0,15	25	15,000
			890847	60x15x17.5-6x30	S0,2	25	15,000
			903423	60x15x17.5-6x30	S0,3	25	15,000
			903424	70x15x19-6x30	S0,15	25	15,000
			34043555	70x15x19-6x30	S0,2	25	15,000
			890848	70x15x19-6x30	S0,3	25	15,000
			34043557	70x15x19-6x30	S0,5	25	15,000
			903425	80x15x19-6x30	S0,15	25	12,000
			890849	80x15x19-6x30	S0,3	25	12,000
			52RDZ	890810	70x6x15-6x30	SH0,3	25
34042794	80x10x15-6x30			SH0,35	25	20,000	

**PREMIUM\*\*\* SHAFT MOUNTED ROUND BRUSHES**

For stainless steel



Shaft mounted round brushes are ideal for machining hard-to-reach parts. With this product you will obtain a tool that can be used on both straight grinders and drilling machines. Knotted wire brushes are suitable for removing rust, cleaning, smoothing, polishing, matting and roughening.

Twisted shaft mounted round brushes are designed for welding and removing scale and paint.

	Shape	Type no.	Dimension	Specification	PU	Max. RPM
		52RDW				
		890812	20x4x3-6x30	E0,2INOX	25	20,000
		890813	30x6x6.5-6x30	E0,2INOX	25	20,000
		890814	40x9x9-6x30	E0,2INOX	25	18,000
		890815	40x9x9-6x30	E0,3INOX	25	18,000
		890817	40x13.5x9-6x30	E0,3INOX	25	18,000
		34043559	50x10x12.5-6x30	E0,2INOX	25	15,000
		890819	50x10x12.5-6x30	E0,3INOX	25	15,000
		890820	50x15x12.5-6x30	E0,2INOX	25	15,000
		890821	50x15x12.5-6x30	E0,3INOX	25	15,000
		890822	60x10x17.5-6x30	E0,2INOX	25	15,000
		890823	60x10x17.5-6x30	E0,3INOX	25	15,000
		890827	60x15x17.5-6x30	E0,2INOX	25	15,000
		890828	60x15x17.5-6x30	E0,3INOX	25	15,000
		895521	70x15x19-6x30	E0,2INOX	25	15,000
		890831	70x15x19-6x30	E0,3INOX	25	15,000
		890832	80x10x19-6x30	E0,3INOX	25	12,000
		890835	80x15x19-6x30	E0,3INOX	25	12,000
		52RDZ				
		890811	70x6x15-6x30	E0,35INOX	25	20,000

**PREMIUM\*\*\* SHAFT MOUNTED ROUND BRUSHES**

For nonferrous metals



Shaft mounted round brushes are ideal for machining hard-to-reach parts. With this product you will obtain a tool that can be used on both straight grinders and drilling machines.

Knotted shaft mounted round brushes are suitable for removing rust, cleaning, smoothing, polishing, matting and roughening.

	Shape	Type no.	Dimension	Specification	PU	Max. RPM
		52RDW				
		23472	40x9x9-6x30	M0,3	25	18,000
		23473	50x10x12.5-6x30	M0,3	25	15,000
		903337	50x15x12.5-6x30	M0,2	25	15,000
		34043560	50x15x12.5-6x30	M0,3	25	15,000
		23474	60x10x17.5-6x30	M0,3	25	15,000
		199648	70x15x19-6x30	M0,2	25	15,000
		903339	70x15x19-6x30	M0,3	25	15,000



**PREMIUM★★★ SHAFT MOUNTED ROUND BRUSHES**



For universal use



Shaft mounted round brushes are ideal for machining hard-to-reach parts. With this product you will obtain a tool that can be used on both straight grinders and drilling machines.

Shaft mounted round brushes with silicon carbide are very hard and thus enable very high stock removal rates. Their use includes deburring work

on various workpieces made of practically any material, such as steel, aluminium, stainless steel, copper, brass, etc. In addition, silicon carbide is used for wood structuring.

	Shape	Type no.	Dimension	Specification	PU	Max. RPM	
		52RDK	34043572	50x20x12.5-6x30	C180	25	15,000
			903363	63x10x18-6x30	C320	25	15,000
			908265	70x20x19-6x30	C120	25	15,000
			908264	70x20x19-6x30	C180	25	15,000
			908263	70x20x19-6x30	C320	25	15,000





A close-up, low-angle shot of a floor-standing grinder. The central focus is a large, circular, blue brush wheel with a textured surface. The wheel is mounted on a metal frame. To the left, a metal arm or handle is visible, secured with a screw. The background is blurred, showing the structural elements of the machine. The overall color palette is dominated by blues and greys, with a white semi-transparent banner across the middle containing text.

## **3.3 BRUSHES**

### FLOORSTANDING GRINDER



## BRUSHES FOR FLOORSTANDING GRINDERS

A floorstanding grinder is a versatile machine used in many workshops to work on different materials. The wide assortment of TYROLIT tool brushes therefore has the right shape, wire type and specification for every application.

Knotted round brushes, with and without grain, are ideal for removing rust, cleaning, smoothing, polishing, matting and roughening. Twisted round brushes, on the other hand, are suitable for rough work such as welding and removing scale and paint.

### Formen



**1RDW** Round brushes

For removing rust, cleaning, smoothing, polishing, matting and roughening



**1RDK** Round brushes

For matting and glazing, coated with grain



**1RDZ** Round brushes

For welding and for removal of scale and paint



## Application recommendations



Performance level	Specification	Pages	Steel	Stainless steel	All in one steel
<b>PREMIUM***</b>	S...	154	•		
	SH...	154	•		
	SZ...	154	•		
	E... INOX	155		•	
	C...	155			•
	A...	155			•

Items with grey lettering are only available on request.

## Dimensions round brushes

200 x 26 x 40 x 32

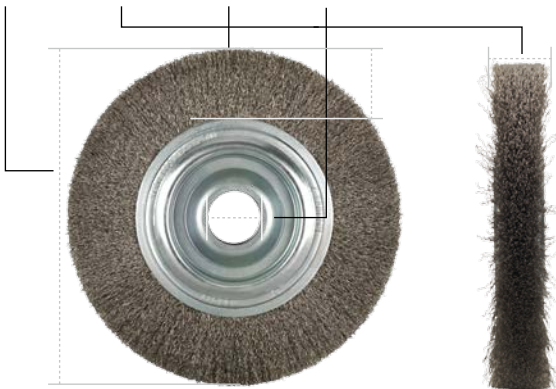

## Optimum peripheral speed

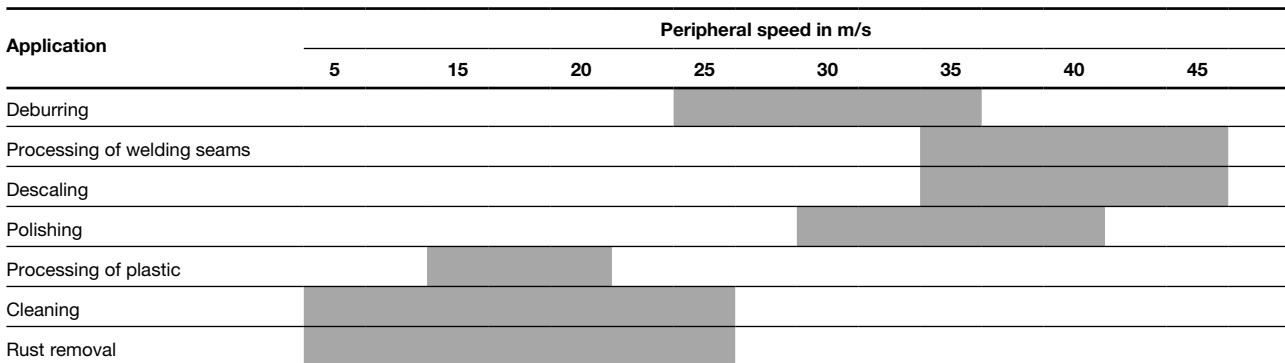



**PREMIUM\*\*\* ROUND BRUSHES**

For steel



Round brushes for floorstanding grinders. TYROLIT will provide you with the appropriate wire brush for your application depending on the wire type. Twisted wire brushes are used for preparing surfaces and removing rust, scales and concrete residue.

Wire brushes with knotted wire can also be used to remove rust and paint, as well as for fine grinding. Our products are also frequently used to clean welding seams.

	Shape	Type no.	Dimension	Specification	PU	Max. RPM	
		1RDW	896630	80x22x20x12.5	S0,3	1	10,000
			896109	100x20x24x20	S0,3	1	6,000
			896237	100x20x24x20	S0,5	1	6,000
			896111	125x24x36x20	S0,3	1	6,000
			896238	125x24x36x20	S0,5	1	6,000
			896115	150x18x27x32	S0,3	1	6,000
			896239	150x18x27x32	S0,5	1	6,000
			896241	180x22x42x32	S0,3	1	6,000
			896243	180x22x42x32	S0,5	1	6,000
			927369	200x26x40x20	S0,3	1	4,500
			894770	200x26x40x32	S0,3	1	4,500
			896244	200x26x40x32	S0,5	1	4,500
			896121	200x36x40x32	S0,3	1	4,500
			896245	200x36x40x32	S0,5	1	4,500
			896123	200x45x40x32	S0,3	1	4,500
			896246	250x38x50x32	S0,3	1	3,600
			896247	250x38x50x32	S0,5	1	3,600
			943863	250x38x50x100	S0,5	1	3,600
			920436	250x42x50x100	S0,3	1	3,600
			938384	300x38x60x25.4	S0,3	1	3,000
920824	300x38x60x100	S0,3	1	3,000			
923064	300x48x60x100	S0,3	1	3,000			
		1RDZ	903404	100x18x22x16	SH0,35	1	11,000
			903409	100x18x22x16	SH0,5	1	11,000
			903407	180x18x34x22.2	SH0,35	1	9,000
			903411	180x18x34x22.2	SH0,5	1	9,000
			903408	200x22x44x40	SH0,35	1	8,500
			903413	200x22x44x40	SH0,5	1	8,500
			915557	300x10x65x25.4	SZ0,5	1	4,500
			915555	300x8x65x25.4	SZ0,5	1	4,500

**PREMIUM★★★ ROUND BRUSHES**

For stainless steel



The versatile round brushes for floorstanding grinders are used in a variety of industries. These wire brushes with knotted wire can be used to remove rust and paint, as well as for fine grinding. They also come in useful for polishing and matting stainless steel workpieces.

TYROLIT wire brushes are manufactured to the highest standards to make work for the operator easier and safer.

	Shape	Type no.	Dimension	Specification	PU	Max. RPM
	1RDW	929849	100x20x24x10	E0,1INOX	1	6,000
		896110	100x20x24x20	E0,3INOX	1	6,000
		896113	125x24x36x20	E0,3INOX	1	6,000
		896116	150x18x27x32	E0,3INOX	1	6,000
		128345	180x22x42x32	E0,3INOX	1	6,000
		935157	200x26x40x20	E0,3INOX	1	4,500
		896119	200x26x40x32	E0,3INOX	1	4,500
		896122	200x36x40x32	E0,3INOX	1	4,500
		896124	200x45x40x32	E0,3INOX	1	4,500
		939696	250x60x50x50.8	E0,4INOX	1	3,600
		939697	300x60x60x50.8	E0,4INOX	1	3,600

**PREMIUM★★★ ROUND BRUSHES**

For universal use



The versatile round brushes for floorstanding grinders are used in a variety of industries. Wire brushes with silicon carbide are very hard and thus enable very high stock removal rates. Their use includes deburring work on various workpieces made of practically any material, such as steel, aluminium, stainless steel, copper, brass, etc. In addition, silicon carbide is used for wood structuring.

less abrasive. They are primarily used in wood structuring, but also for light deburring if very small rounded edges are desired. TYROLIT wire brushes are manufactured to the highest standards to make work for the operator easier and safer.

Round brushes with aluminium oxide are somewhat softer and therefore

	Shape	Type no.	Dimension	Specification	PU	Max. RPM
	1RDK	34043575	100x11x22x20	C120	1	12,000
		34043576	100x11x22x20	C320	1	12,000
		34043577	125x13x22x20	C320	1	10,000
		34043578	150x13x34x32	C320	1	8,000
		916720	150x15x29x40	C320	1	8,000
		34043579	180x15x44x40	C320	1	6,000
		227435	200x13x43x50.8	C320	1	6,000
		898839	300x19x30x50.8	C120	1	3,000
		7213	300x19x30x50.8	A120	1	3,000



**KROLIT**

WORK WEAR





## **3.4 BRUSHES**

### HAND-GUIDED GRINDING



## HAND-OPERATED TOOL BRUSHES

Brushes are suitable for universal use and can be employed in a very wide range of applications: deburring, cleaning welding seams or the surfaces of virtually any material.

With a large selection of shapes, it is possible to clean and work on hard-to-reach areas. Our range even includes a suitable hand brush for cleaning spark plugs.

The TYROLIT range of brushes offers the right wire type and specification for every application.

## Application recommendations



Performance level	Specification	Pages	Steel	Stainless steel	Aluminum
<b>PREMIUM***</b>	S...	160	●		
	E... INOX	160		●	
	M...	161			●

Items with grey lettering are only available on request.

## Shapes



**90HDG** Hand brush

Hand brush for universal use



**90HDW** Hand brush

For working on nonferrous metals with knotted brass wire



**90SDW** Hand brush

For smooth finishing of profiled surfaces



**90ZKDW** Hand brush

Specially for cleaning spark plugs



**90HKE** Hand brush

V-shaped, for cleaning hard-to-reach welding seams and fillet welds

## Dimensions hand brushes

260 x 10 x 28 x 138

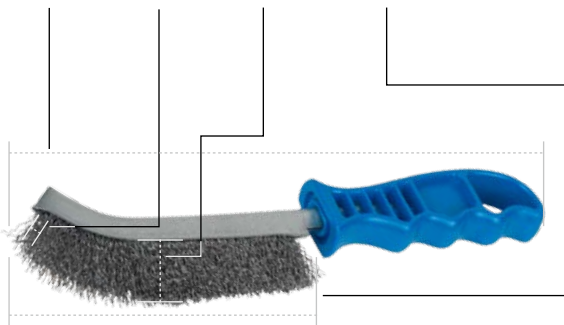

**PREMIUM★★★ HAND-OPERATED BRUSHES**

For steel



TYROLIT hand brushes are suitable for practically any application. This tool enables the deburring and cleaning of welding seams or surfaces. Depending on the shape and wire sequence, these brushes can also clean hard-to-reach areas, such as welding seams and fillet welds, and remove slag and scale.

We have also expanded our range to include a special shape to clean spark plugs. Our hand brushes are also available with plastic instead of wooden handles for use in the food industry. File brushes are specially designed to clean metal and wood files.

	Shape	Type no.	Dimension	Specification	PU	Wire sequence
		90HDG	895498	290x22x25x140	S0,3	12 2
			895576	290x28x25x140	S0,3	12 3
			895577	290x32x25x140	S0,3	12 4
			895578	290x38x25x140	S0,3	12 5
			199657	290x42x25x140	S0,35	12 6
		90SDW	896223	260x10x28x135	S0,3	12 1
		90HKE	199682	290x35x35x135	S0,35	12 3
		90FDG	899851	210x25x25x100	S0,3	12 -

**PREMIUM★★★ HAND-OPERATED BRUSHES**

For stainless steel



These brushes are stainless steel specialists when it comes to deburring and cleaning welding seams or surfaces. Depending on the shape and wire sequence, these brushes can also clean hard-to-reach areas, such as welding seams and fillet welds, and remove slag and scale. We have also expanded our range to include a special shape to clean spark plugs.

Our hand brushes are also available with plastic instead of wooden handles for use in the food industry.

	Shape	Type no.	Dimension	Specification	PU	Wire sequence
		90HDG	895579	290x22x25x140	E0,3INOX	12 2
			895580	290x28x25x140	E0,3INOX	12 3
			896207	290x32x25x140	E0,3INOX	12 4
			896209	290x38x25x140	E0,3INOX	12 5
			90SDW	896224	260x10x28x135	E0,3INOX
		90HKE	199689	290x35x35x135	E0,35INOX	12 3



**PREMIUM★★★ HAND-OPERATED BRUSHES**

For nonferrous metals



TYROLIT hand brushes are suitable for practically any application. This tool enables the deburring and cleaning of welding seams or surfaces. Depending on the shape and wire sequence, these brushes can also clean hard-to-reach areas, such as welding seams and fillet welds, and remove slag and scale.

We have also expanded our range to include a special shape to clean spark plugs. Our hand brushes are also available with plastic instead of wooden handles for use in the food industry.

	Shape	Type no.	Dimension	Specification	PU	Wire sequence
		90HDW	896217	290x22x25x140	M0,3	12 2
			895581	290x28x25x140	M0,3	12 3
			896219	290x32x25x140	M0,3	12 4
			896220	290x38x25x140	M0,3	12 5
			199658	290x42x25x140	M0,3	12 6
		90SDW	199678	260x10x28x135	M0,3	12 1
		90ZKDW	903434	145x18x15x35	M0,15	12 3







# CATALOGUE 18

## COATED ABRASIVES

<b>Grinding information</b>	<b>164</b>
Specification	164
Explanation of labels	165
Machine pictograms	165
Colour codes	165
<b>Angle grinder</b>	<b>167</b>
4.1 Flap discs	168
4.2 Polishing program	184
4.3 Rough cleaning wheels	191
4.4 Fibre discs	195
4.5 Surface Conditioning Material	209
4.6 Quick Change Disc	215
<b>Straight grinder</b>	<b>227</b>
4.7 Spiral belts	228
4.8 Rough cleaning wheels	233
4.9 Spindle-mounted fleece flap wheels and mounted flap wheels	237
<b>Belt grinder</b>	<b>249</b>
4.10 Belts	250
Belts for mini belt grinder	250
Belts for portable belt grinder	255
Belts for contact grinder	257
<b>Hand sanding and super finishing</b>	<b>263</b>
4.11 Rolls, paper/cloth/fleece	264
4.12 Sheets, paper/cloth/fleece	273
<b>Dual action sander</b>	<b>281</b>
4.13 TYROLIT Fast Change Discs	282
<b>Burnishing machine</b>	<b>289</b>
4.14 Rollers	290
<b>Floorstanding grinder</b>	<b>295</b>
4.15 Rollers	296

# SPECIFIC INFORMATION

## SPECIFICATION

### ZA-P43N

	<b>N</b>	Underlay made of natural fibres
	<b>V</b>	Underlay made of vulcanised fibres
	<b>A/B/C/F</b>	Weight of paper
	<b>C J</b>	Cloth – flexible
	<b>C JJ</b>	Cloth – very flexible
	<b>C JX</b>	Cloth – semi-flexible
	<b>PC-X</b>	Polycotton – rigid
	<b>PC-Y</b>	Polycotton – very rigid
	<b>PE-Y</b>	Polyester – very rigid
	<b>FI</b>	Film
	<b>01</b>	Structural steel, carbon steel, aluminium, nonferrous metals etc.
	<b>02</b>	Structural steel, carbon steel, aluminium, nonferrous metals etc.; with active additives
	<b>03</b>	Stainless steel, steel and soft metals; with active additives; wet and dry
	<b>06</b>	Structural steel, carbon steel, aluminium, nonferrous metals, wood etc.; with active additives
	<b>07</b>	All metals; wet and dry
	<b>21</b>	Paint, lacquers, composite materials, gel coat; for universal use; light with stearate layer
	<b>22</b>	Paint, lacquers, composites, gel coat; for universal use; aggressive with stearate layer
	<b>35</b>	Wood, lacquers, paint, for universal use
	<b>41</b>	Structural steel, carbon steel, aluminium etc.; low to medium pressure, active additives
	<b>43</b>	Steel, carbon steel, aluminium etc.; medium to high pressure; active additives
	<b>45</b>	Steel, carbon steel, stainless steel etc.; low pressure; active additives
	<b>47</b>	Stainless steel, high-alloy steel, hardened steel; medium to high pressure; active additives and Topsize
	<b>48</b>	Stainless steel, high-alloy steel, hardened steel; medium to high pressure; active additives and Topsize
	<b>65</b>	Stone, tiles, composites, gel coat, epoxies, glass etc.
	<b>68</b>	Stone; wet and dry
	<b>93</b>	Stainless steel, high-alloy steel, hardened steel; medium to high pressure; active additives and Topsize
	<b>P</b>	PREMIUM***
	<b>B</b>	BASIC*
<b>ZA</b>		Zirconium
<b>A</b>		Aluminium oxide
<b>CA</b>		Sintered aluminium oxide
<b>C</b>		Silicium carbide

**Active additives:** for cooler grinding

**Topsize:** for cooler grinding on stainless steel and high-alloy steel

**Stearate layer:** reduces loading and smearing

Coated  
abrasives



## Flap discs product label



## Machine pictograms

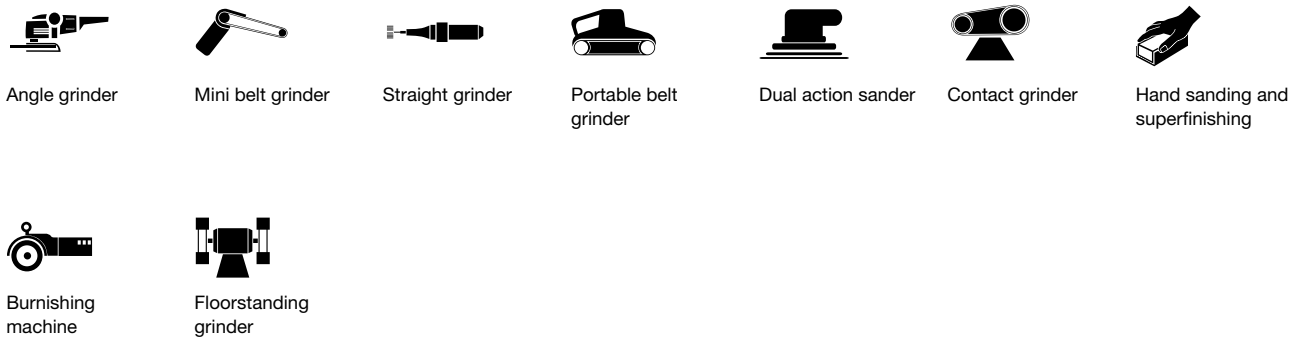

## Colour codes

<b>Label</b>	Steel	INOX	2in1	Nonferrous metals
<b>Colour code</b>	Blue	Red	Blue	Orange
<b>Material</b>	Steel	Stainless steel	steel and stainless steel	Aluminium, copper, zinc, brass, bronze, stone









## **4.1 FLAP DISCS** ANGLE GRINDER





## FLAP DISCS FOR ANGLE GRINDERS

Working with an angle grinder is one of the most important processes in the trade and industrial sectors for processing all types of metals. TYROLIT offers a comprehensive assortment of flap discs for this purpose.

Whatever the application and whichever shape you prefer: we have the right product for you.

Since TYROLIT always puts your health first, we offer flap discs with a core made from natural fibres, which can even be trimmed. Innovative and

precisely adapted to the application. That's TYROLIT for you!

On the following pages you will find the perfect tool for your requirements thanks to the uniform colour code for all materials.



# Application recommendations



Performance level	Specification	Pages	Steel	Stainless steel	2in1	NF metals
<b>PREMIUM***</b>	A...-B	171	●			
	ZA...-B	170-175	●		●	
	CA...-B	176-178		●		
	CA...-B	179				●
	120-M	175			●	



Performance level	Specification	Pages	2in1
<b>STANDARD**</b>	ZA...-B	179-181	●



Performance level	Specification	Pages	2in1
<b>BASIC*</b>	ZA...-B	181-182	●

Items with grey lettering are only available on request.

## Shapes



**27A** Flap disc

Depressed-centre design with fibreglass core. This shape creates the perfect angle of 15° - 20°.



**28A** Flap disc

Straight design with fibreglass core. This shape ensures optimum use of the abrasive cloth with a grinding angle of 0-15°.



**28NF** Flap disc

Core made from natural fibres for easy trimming - straight.



**28S SOFTJOB** Flap disc

The arrangement of the flaps differs from conventional flap discs, making it even more flexible in use.



**28N** Flap disc

Straight design with plastic core. This shape ensures optimum use of the abrasive cloth with a grinding angle of 0-15°. The core can also be reset in order to use up the abrasive cloth completely.

Coated abrasives

# PREMIUM\*\*\* FLAP DISC LONGLIFE FOR STEEL

+ **Great savings potential**

100% use of the disc is guaranteed through simple trimming.

+ **Environmentally-friendly**

The innovative natural fibre core is completely free of fibre glass and therefore reduces the environmental load.



+ **Unparalleled performance**

The newly developed high-tech zircon fabric enables outstanding removal results with the longest lifetime.

The PREMIUM\*\*\* LONGLIFE is a high-performance flap disc for steel and boasts an excellent stock removal rate and the longest lifetime. A stock removal rate of more than

4,000g opens up a completely new dimension.

A natural fibre core gives the tool additional flexibility, meaning that the



PREMIUM\*\*\* LONGLIFE fits the work-piece surface perfectly and creates clean grinding transitions.

## PREMIUM\*\*\* FLAP DISC LONGLIFE for steel



	Shape	Type no.	Dimension	Specification	PU
	28NF	34063393	115x22.23	ZA40-B	10
		34063394	115x22.23	ZA60-B	10
		34063396	115x22.23	ZA80-B	10
		34063397	115x22.23	ZA120-B	10
		34063388	125x22.23	ZA40-B	10
		34063389	125x22.23	ZA60-B	10
		34063390	125x22.23	ZA80-B	10
		34063391	125x22.23	ZA120-B	10
		34063398	150x22.23	ZA40-B	10
		34063399	150x22.23	ZA60-B	10
		34063400	150x22.23	ZA80-B	10

Coated abrasives

	Shape	Type no.	Dimension	Specification	PU
	 28NF	34063401	150x22.23	ZA120-B	10
		34063402	178x22.23	ZA40-B	10
		34063403	178x22.23	ZA60-B	10
		34063404	178x22.23	ZA80-B	10
		34063406	178x22.23	ZA120-B	10



**PREMIUM\*\*\* FLAP DISC**

For steel



The PREMIUM\*\*\* flap disc for steel is a versatile professional tool suitable for universal grinding tasks. With this disc, users will achieve perfect surfaces on steel, as well as the best results for surface or edge grinding and deburring work.

The supporting disc is made of rigid fibre glass and is therefore ideally suited to use on powerful angle grinders.

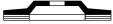
	Shape	Type no.	Dimension	Specification	PU	
	 27A	668630	115x22.23	A40-B	10	
		668631	115x22.23	A60-B	10	
		668632	115x22.23	A80-B	10	
		668633	115x22.23	A120-B	10	
		668634	125x22.23	A40-B	10	
		668635	125x22.23	A60-B	10	
		668637	125x22.23	A80-B	10	
		896379	125x22.23	A120-B	10	
		668638	178x22.23	A40-B	10	
		668640	178x22.23	A60-B	10	
		668641	178x22.23	A80-B	10	
		75193	178x22.23	A120-B	10	
		 28A	668679	115x22.23	A40-B	10
			795077	115x22.23	A60-B	10
699984	115x22.23		A80-B	10		
642626	115x22.23		A120-B	10		
668681	125x22.23		A40-B	10		
728528	125x22.23		A60-B	10		
817672	125x22.23		A80-B	10		
817935	125x22.23		A120-B	10		
668683	178x22.23		A40-B	10		
886353	178x22.23		A60-B	10		
642627	178x22.23	A80-B	10			
642628	178x22.23	A120-B	10			

Coated abrasives

# PREMIUM\*\*\* FLAP DISC LONGLIFE FOR STEEL AND STAINLESS STEEL

+ **Excellent overall abrasion**  
Offers not only a long service life, but also exceptional results in terms of abrasiveness.

+ **Robust construction**  
Through the increased number of closely spaced flaps, this disc can withstand even the highest loads.



+ **Longest lifetime**  
The PREMIUM\*\*\* LONGLIFE offers an even longer service life with consistent grinding results.

The PREMIUM\*\*\* LONGLIFE flap disc offers the longest lifetime and an excellent stock removal rate. This flap disc is used both on high alloyed

steels and stainless steel, as well as on unalloyed and low alloyed steels. Problem-free welding as well as edge and surface grinding, particu-

larly when used on powerful angle grinders.

## PREMIUM\*\*\* FLAP DISC LONGLIFE for steel and stainless steel



	Shape	Type no.	Dimension	Specification	PU
	28N	680369	115x22.23	ZA40-B	10
		680373	115x22.23	ZA60-B	10
		680376	115x22.23	ZA80-B	10
		680377	115x22.23	ZA120-B	10
		680379	125x22.23	ZA40-B	10
		680380	125x22.23	ZA60-B	10
		680383	125x22.23	ZA80-B	10
		680386	125x22.23	ZA120-B	10
		680387	178x22.23	ZA40-B	10
		680388	178x22.23	ZA60-B	10
		680389	178x22.23	ZA80-B	10
		680390	178x22.23	ZA120-B	10

Coated abrasives



**PREMIUM\*\*\* FLAP DISC**  
FASTCUT for steel and stainless steel



The PREMIUM\*\*\* FASTCUT is synonymous with excellent, specific abrasion of material. As a result, you will achieve your goal faster, and the disc will remain easy cutting and abrasive over its entire lifetime. The TYROLIT FASTCUT flap disc is the perfect tool for demanding grinding jobs, such as edge grinding and welding. It is used both on high alloyed

steels and stainless steel, as well as on unalloyed and low alloyed steels. The additional TOP SIZE coating provides cool grinding. It is also possible to use it on aluminium, to a limited extent.

	Shape	Type no.	Dimension	Specification	PU			
		27A	528580	100x16	ZA40-B	10		
		643845	100x16	ZA60-B	10			
		643846	100x16	ZA80-B	10			
		160229	115x22.23	ZA40-B	10			
		160230	115x22.23	ZA60-B	10			
		160235	115x22.23	ZA80-B	10			
		160240	125x22.23	ZA40-B	10			
		160242	125x22.23	ZA60-B	10			
		160244	125x22.23	ZA80-B	10			
		34166360	150x22.23	ZA40-B	10			
		34166362	150x22.23	ZA60-B	10			
		34166363	150x22.23	ZA80-B	10			
		160245	178x22.23	ZA40-B	10			
		160246	178x22.23	ZA60-B	10			
		160247	178x22.23	ZA80-B	10			
		28A	160249	115x22.23	ZA40-B	10		
		160251	115x22.23	ZA60-B	10			
		160252	115x22.23	ZA80-B	10			
		160254	125x22.23	ZA40-B	10			
		160255	125x22.23	ZA60-B	10			
		160256	125x22.23	ZA80-B	10			
		34166364	150x22.23	ZA40-B	10			
		34166365	150x22.23	ZA60-B	10			
		34166366	150x22.23	ZA80-B	10			
		160257	178x22.23	ZA40-B	10			
		160258	178x22.23	ZA60-B	10			
		160260	178x22.23	ZA80-B	10			
				28N	458028	115x22.23	ZA40-B	10
				458029	115x22.23	ZA60-B	10	
				458030	115x22.23	ZA80-B	10	
458034	125x22.23			ZA40-B	10			
458033	125x22.23			ZA60-B	10			
458031	125x22.23			ZA80-B	10			
458035	178x22.23			ZA40-B	10			
458038	178x22.23			ZA60-B	10			
458040	178x22.23			ZA80-B	10			



Coated abrasives

**PREMIUM\*\*\* FLAP DISC**  
OVERLAP for steel and stainless steel



The PREMIUM\*\*\* OVERLAP is the right tool to effortlessly access hard-to-reach areas. Its flaps overlap by about 10 mm and make light work of the finishing of fillet welds, grooves and flutes.

The OVERLAP flaps also impress in terms of stock removal rate and lifetime when used on steel and stainless steel.





	Shape	Type no.	Dimension	Specification	PU
	 27A	540688	125x22.23	ZA40-B	10
		540689	125x22.23	ZA60-B	10

**PREMIUM\*\*\* FLAP DISC**  
2in1 for steel and stainless steel





The PREMIUM\*\*\* 2in1 flap disc combines an excellent lifetime with very high specific abrasion. The TYROLIT 2in1 flap disc is used both on high alloyed steels and

stainless steel, as well as on unalloyed and low alloyed steels. Problem-free welding as well as edge and surface grinding, particularly when used on powerful angle grinders.

	Shape	Type no.	Dimension	Specification	PU
	 27N	34043471	115x22.23	ZA40-B	10
		34043472	115x22.23	ZA60-B	10
		34043473	115x22.23	ZA80-B	10
		34043474	115x22.23	ZA120-B	10
		34043475	125x22.23	ZA40-B	10
		34043476	125x22.23	ZA60-B	10
		34043477	125x22.23	ZA80-B	10
		34043478	125x22.23	ZA120-B	10
		34043479	150x22.23	ZA40-B	10
		34043480	150x22.23	ZA60-B	10
	 27A	729764	100x16	ZA40-B	10
		730559	100x16	ZA60-B	10
		730560	100x16	ZA80-B	10
		78049	100x16	ZA120-B	10
		668642	115x22.23	ZA40-B	10
		668644	115x22.23	ZA60-B	10
		668649	115x22.23	ZA80-B	10
		643803	115x22.23	ZA120-B	10
		668663	125x22.23	ZA40-B	10
		668664	125x22.23	ZA60-B	10

Coated abrasives



	Shape	Type no.	Dimension	Specification	PU		
		27A	668665	125x22.23	ZA80-B	10	
		643805	125x22.23	ZA120-B	10		
		519212	150x22.23	ZA40-B	10		
		519213	150x22.23	ZA60-B	10		
		519214	150x22.23	ZA80-B	10		
		519215	150x22.23	ZA120-B	10		
		668670	178x22.23	ZA40-B	10		
		668672	178x22.23	ZA60-B	10		
		668673	178x22.23	ZA80-B	10		
		643807	178x22.23	ZA120-B	10		
			28A	34166327	100x16	ZA40-B	10
			34166328	100x16	ZA60-B	10	
			34166331	100x16	ZA80-B	10	
			34166333	100x16	ZA120-B	10	
668686	115x22.23		ZA40-B	10			
668687	115x22.23		ZA60-B	10			
668691	115x22.23		ZA80-B	10			
846344	115x22.23		ZA120-B	10			
668692	125x22.23		ZA40-B	10			
668693	125x22.23		ZA60-B	10			
668694	125x22.23		ZA80-B	10			
645145	125x22.23		ZA120-B	10			
668696	178x22.23		ZA40-B	10			
668697	178x22.23		ZA60-B	10			
668698	178x22.23	ZA80-B	10				
643823	178x22.23	ZA120-B	10				

**PREMIUM\*\*\* FLAP DISC**  
COMBI for steel and stainless steel



The PREMIUM\*\*\* COMBI combines abrasive cloth and fabric in one tool. This enables two work steps to be performed in one. Material removal and simultaneous finishing of surfaces produce an optimal result. The long lifetime of the PREMIUM\*\*\* COMBI dramatically increases

economic efficiency in comparison to conventional "surface conditioning" discs. The disc has also been specially developed to achieve good results at high speeds on non-adjustable angle grinders (max. 80 m/s).

	Shape	Type no.	Dimension	Specification	PU	
		27PLCA	742167	115x22.23	120-M	5
		742168	125x22.23	120-M	5	

# PREMIUM★★★ FLAP DISC

## CERABOND FLAP DISC FOR STAINLESS STEEL

+ **Enhanced abrasiveness**  
A new, wider PREMIUM cloth and the CERABOND bond system offer high stock removal on the workpiece.

+ **Longer lifetime**  
The unique bond system prevents premature grain break-out and leads to a long lifetime for the product.



+ **Enhanced economic efficiency**  
Thanks to the self-sharpening ceramic grain, the CERABOND flap disc is also ideal for demanding grinding jobs.

We at TYROLIT always endeavour to bring our customers innovative products and a comprehensive assortment. For this reason, TYROLIT has now extended the CERABOND family to include the new CERAMIC flap discs.

A unique bond system combined with a high-performance PREMIUM cloth offers the user greater abrasiveness. This flap disc is particularly suitable for stainless steels and demanding grinding applications. In addition, the unique bond system prevents prema-

ture grain break-out and leads to a long product lifetime. The additional TOP SIZE coating ensures cooler grinding, allowing a longer lifetime and reducing discolouration on the workpiece surface.

### PREMIUM★★★ FLAP DISC





CERABOND flap disc for stainless steel



	Shape	Type no.	Dimension	Specification	PU
	27A	34166139	100x16	CA40-B	10
		34166140	100x16	CA60-B	10
		34166161	100x16	CA80-B	10
		34043514	115x22.23	CA40-B	5
		34043515	115x22.23	CA60-B	5
		34165680	115x22.23	CA80-B	5
		34043516	125x22.23	CA40-B	5

Coated abrasives



	Shape	Type no.	Dimension	Specification	PU
	 27A	34043517	125x22.23	CA60-B	5
		34165681	125x22.23	CA80-B	5
		34166162	150x22.23	CA40-B	10
		34166163	150x22.23	CA60-B	10
		34166164	150x22.23	CA80-B	10
		34166166	178x22.23	CA40-B	5
		34166167	178x22.23	CA60-B	5
		34166168	178x22.23	CA80-B	5
	 28A	34166169	100x16	CA40-B	10
		34166170	100x16	CA60-B	10
		34166171	100x16	CA80-B	10
		34166172	115x22.23	CA40-B	5
		34166173	115x22.23	CA60-B	5
		34166174	115x22.23	CA80-B	5
		34166175	125x22.23	CA40-B	5
34166176		125x22.23	CA60-B	5	
34166177		125x22.23	CA80-B	5	
34166178		150x22.23	CA40-B	10	
34166179		150x22.23	CA60-B	10	
34166180		150x22.23	CA80-B	10	
 27N	34057966	115x22.23	CA40-B	5	
	34057967	115x22.23	CA60-B	5	
	34165677	115x22.23	CA80-B	5	
	34057968	125x22.23	CA40-B	5	
	34057969	125x22.23	CA60-B	5	
	34165679	125x22.23	CA80-B	5	



Coated abrasives

**PREMIUM\*\*\* FLAP DISC**  
CERAMIC for Inox



Thanks to the self-sharpening ceramic abrasive grain, the PREMIUM\*\*\* CERAMIC flap disc is particularly suitable for stainless steels and demanding grinding applications. The additional TOP SIZE coating ensures cool grinding, allowing a longer

tool lifetime and reducing discolouration on the workpiece surface. Thanks to the self-sharpening characteristic of the abrasive grain, a more even surface quality is achieved over the entire lifetime of the disc.

	Shape	Type no.	Dimension	Specification	PU
	 27A	645130	115x22.23	CA40-B	10
		645132	115x22.23	CA60-B	10
		34166620	115x22.23	CA80-B	10
		645135	125x22.23	CA40-B	10

**PREMIUM★★★ FLAP DISC**  
**CERAMIC for Inox**



Thanks to the self-sharpening ceramic abrasive grain, the PREMIUM\*\*\* CERAMIC flap disc is particularly suitable for stainless steels and demanding grinding applications. The additional TOP SIZE coating ensures cool grinding, allowing a longer

tool lifetime and reducing discolouration on the workpiece surface. Thanks to the self-sharpening characteristic of the abrasive grain, a more even surface quality is achieved over the entire lifetime of the disc.

	Shape	Type no.	Dimension	Specification	PU		
		27A	645137	125x22.23	CA60-B	10	
		34166671	125x22.23	CA80-B	10		
		34166673	150x22.23	CA40-B	10		
		34166678	150x22.23	CA60-B	10		
		34166680	150x22.23	CA80-B	10		
		34166681	178x22.23	CA40-B	10		
		34166685	178x22.23	CA60-B	10		
		34166686	178x22.23	CA80-B	10		
			28A	719797	115x22.23	CA40-B	10
			719798	115x22.23	CA60-B	10	
34166687	115x22.23		CA80-B	10			
719799	125x22.23		CA40-B	10			
719800	125x22.23		CA60-B	10			
34166688	125x22.23		CA80-B	10			
34166855	150x22.23		CA40-B	10			
34166857	150x22.23		CA60-B	10			
34166858	150x22.23		CA80-B	10			
34166859	178x22.23		CA40-B	10			
34166860	178x22.23	CA60-B	10				
34166861	178x22.23	CA80-B	10				
	28N	719840	115x22.23	CA40-B	10		
	719841	115x22.23	CA60-B	10			
	34166863	115x22.23	CA80-B	10			
	719846	125x22.23	CA40-B	10			
	719847	125x22.23	CA60-B	10			
	34166865	125x22.23	CA80-B	10			

Coated abrasives

**PREMIUM\*\*\* FLAP DISC**

For nonferrous metals



With the specification developed specifically for nonferrous metals, smearing and dulling of the flap disc is prevented. The ceramic grain promotes self-cleaning and sharpening of the disc during material abrasion.

This tool offers convenient and high-performance results on difficult-to-grind materials such as aluminium, aluminium bronze, aluminium base alloy, copper, bronze, brass and nickel silver.

	Shape	Type no.	Dimension	Specification	PU		
		27A	707005	115x22.23	CA40-B	10	
		707007	115x22.23	CA60-B	10		
		707008	115x22.23	CA80-B	10		
		707010	115x22.23	CA120-B	10		
		707011	125x22.23	CA40-B	10		
		707012	125x22.23	CA60-B	10		
		707013	125x22.23	CA80-B	10		
		707014	125x22.23	CA120-B	10		
		707015	178x22.23	CA40-B	10		
		707016	178x22.23	CA60-B	10		
		707017	178x22.23	CA80-B	10		
		707018	178x22.23	CA120-B	10		
			28A	707153	115x22.23	CA40-B	10
			707155	115x22.23	CA60-B	10	
			707156	115x22.23	CA80-B	10	
			707158	115x22.23	CA120-B	10	
			707159	125x22.23	CA40-B	10	
			707160	125x22.23	CA60-B	10	
707161	125x22.23		CA80-B	10			
707163	125x22.23		CA120-B	10			
707165	178x22.23		CA40-B	10			
707166	178x22.23		CA60-B	10			
707167	178x22.23	CA80-B	10				
707168	178x22.23	CA120-B	10				

**STANDARD\*\* FLAP DISC**

2in1 for steel and stainless steel



The STANDARD\*\* 2in1 flap disc offers two advantages. On one hand it offers the user very long lifetime, on the other it guarantees very good specific abrasion.

The TYROLIT 2in1 flap disc is used both on high alloyed steels and stainless steel, as well as on unalloyed and low alloyed steels.

	Shape	Type no.	Dimension	Specification	PU	
		27A	843806	100x16	ZA40-B	10
		455324	100x16	ZA60-B	10	
		455318	100x16	ZA80-B	10	
		257768	100x16	ZA120-B	10	



**STANDARD\*\* FLAP DISC**  
2in1 for steel and stainless steel



	Shape	Type no.	Dimension	Specification	PU		
		27A	572473	115x22.23	ZA40-B	10	
			454393	115x22.23	ZA60-B	10	
			455312	115x22.23	ZA80-B	10	
			50801	115x22.23	ZA120-B	10	
			824385	125x22.23	ZA40-B	10	
			455303	125x22.23	ZA60-B	10	
			458587	125x22.23	ZA80-B	10	
			243069	125x22.23	ZA120-B	10	
			139648	150x22.23	ZA40-B	10	
			139651	150x22.23	ZA60-B	10	
			139653	150x22.23	ZA80-B	10	
			575635	150x22.23	ZA120-B	10	
			580650	178x22.23	ZA40-B	10	
			454396	178x22.23	ZA60-B	10	
			455314	178x22.23	ZA80-B	10	
			243071	178x22.23	ZA120-B	10	
			28A	537021	115x22.23	ZA40-B	10
				537084	115x22.23	ZA60-B	10
				537089	115x22.23	ZA80-B	10
	537093		115x22.23	ZA120-B	10		
	537095		125x22.23	ZA40-B	10		
	537097		125x22.23	ZA60-B	10		
	537110		125x22.23	ZA80-B	10		
	537111		125x22.23	ZA120-B	10		
	537112		178x22.23	ZA40-B	10		
	537113		178x22.23	ZA60-B	10		
	537114		178x22.23	ZA80-B	10		
	537115		178x22.23	ZA120-B	10		
	28N		847917	115x22.23	ZA40-B	10	
			847924	115x22.23	ZA60-B	10	
			847927	115x22.23	ZA80-B	10	
		247165	115x22.23	ZA120-B	10		
		847921	125x22.23	ZA40-B	10		
		847925	125x22.23	ZA60-B	10		
		847928	125x22.23	ZA80-B	10		

Coated abrasives





	Shape	Type no.	Dimension	Specification	PU	
		28N	247366	125x22.23	ZA120-B	10
		847923	178x22.23	ZA40-B	10	
		847926	178x22.23	ZA60-B	10	
		847929	178x22.23	ZA80-B	10	
		247175	178x22.23	ZA120-B	10	

**STANDARD\*\* SOFTJOB**  
2in1 for steel and stainless steel



For us, the STANDARD\*\* Softjob flap disc represents maximum flexibility for machining difficult to access areas. It has a broad application area, comprising: Surface preparation and improvement, preparation of welding work and cleaning of weld seams.

Processing of contours and profiled surfaces, processing of handrails and pipes, cleaning of surfaces, removal of rust and paint residues.



	Shape	Type no.	Dimension	Specification	PU	
		28S	246987	115x22.23	ZA40-B	10
		246988	115x22.23	ZA60-B	10	
		246990	115x22.23	ZA80-B	10	
		246994	115x22.23	ZA120-B	10	
		246995	125x22.23	ZA40-B	10	
		246996	125x22.23	ZA60-B	10	
		246998	125x22.23	ZA80-B	10	
		247001	125x22.23	ZA120-B	10	

**BASIC\* FLAP DISC**  
2in1 for steel and stainless steel



The BASIC\* 2in1 flap disc offers two advantages. On one hand, it offers the user long lifetime, on the other it guarantees good specific abrasion.

The TYROLIT 2in1 flap disc is used both on high alloyed steels and stainless steel, as well as on unalloyed and low alloyed steels.

	Shape	Type no.	Dimension	Specification	PU	
		27A	474872	100x16	ZA40-B	10
		474874	100x16	ZA60-B	10	
		474875	100x16	ZA80-B	10	
		474877	100x16	ZA120-B	10	
		273884	115x22.23	ZA40-B	10	
		273810	115x22.23	ZA60-B	10	
		273871	115x22.23	ZA80-B	10	
		719788	115x22.23	ZA120-B	10	
		273872	125x22.23	ZA40-B	10	
		273873	125x22.23	ZA60-B	10	

**BASIC★** FLAP DISC  
2in1 for steel and stainless steel



	Shape	Type no.	Dimension	Specification	PU		
		27A	273874	125x22.23	ZA80-B	10	
		719793	125x22.23	ZA120-B	10		
		34166866	178x22.23	ZA40-B	10		
		34166867	178x22.23	ZA60-B	10		
		34166869	178x22.23	ZA80-B	10		
		34166870	178x22.23	ZA120-B	10		
			28A	34023527	100x16	ZA40-B	10
			34023528	100x16	ZA60-B	10	
			34023529	100x16	ZA80-B	10	
			34023530	100x16	ZA120-B	10	
320318	115x22.23		ZA40-B	10			
320320	115x22.23		ZA60-B	10			
320322	115x22.23		ZA80-B	10			
719794	115x22.23		ZA120-B	10			
320319	125x22.23		ZA40-B	10			
320321	125x22.23		ZA60-B	10			
320323	125x22.23		ZA80-B	10			
719796	125x22.23		ZA120-B	10			
34166901	178x22.23		ZA40-B	10			
34166902	178x22.23		ZA60-B	10			
34166903	178x22.23		ZA80-B	10			
34166904	178x22.23	ZA120-B	10				
	28N	246870	115x22.23	ZA40-B	10		
	246871	115x22.23	ZA60-B	10			
	246872	115x22.23	ZA80-B	10			
	728649	115x22.23	ZA120-B	10			
	728650	125x22.23	ZA40-B	10			
	728657	125x22.23	ZA60-B	10			
	728659	125x22.23	ZA80-B	10			
	728661	125x22.23	ZA120-B	10			
	34166905	178x22.23	ZA40-B	10			
	34166906	178x22.23	ZA60-B	10			
	34166907	178x22.23	ZA80-B	10			
	34166908	178x22.23	ZA120-B	10			

Coated abrasives



## 4.2 POLISHING PROGRAM ANGLE GRINDER

Coated  
abrasives

TYROLIT





## POLISHING PROGRAM FOR ANGLE GRINDERS

Working with an angle grinder is one of the most important processes in the trade and industrial sectors for processing all types of metals. TYROLIT offers an optimally tailored package for polishing metal.

There are many suppliers of polishing accessories. But anyone who has ever polished knows how important it is that all components should be perfectly matched to one another.

With TYROLIT you can get everything you need from one source. You can tell how perfectly our products are matched from the fact that you can get a mirror finish in only three steps

– without unwanted discolouration due to overheating.

### Shapes



28PCA CONDITIONING



28 PUA PRE-POLISH

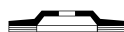

28 PWA POLISH



29EL  
ELASTIC RONDELLER®



Disc Polistar



## Recommended speeds

PREMIUM*** CONDITIONING	PREMIUM*** PRE-POLISH	PREMIUM*** POLISH	PREMIUM*** COMBI
115 mm – 3,500 rpm	115 mm – 4,000 rpm	115 mm – 1,800 rpm	115 mm – 4,000 rpm
125 mm – 3,000 rpm	125 mm – 3,600 rpm	125 mm – 1,500 rpm	125 mm – 3,600 rpm

### Polishing pastes:

- White – high gloss pre-polish (POLISH)
- Blue – high gloss polish (S-POLISH)
- Brown - special polish for nonferrous metals (POLISH-NE)

# TYROLIT PREMIUM\*\*\* POLISHING PROGRAM THREE STEPS TO A PERFECT MIRROR FINISH

### + Preparation

#### Preparing the untreated workpiece

To prepare the untreated material and get a mirror finish, you need:

PREMIUM\*\*\* fibre discs ZA-P48 Page 201

PREMIUM\*\*\* 2in1 flap discs Page 172

STANDARD\*\* SOFTJOB Page 181

**Our recommendation:** grit size 120 or 80 depending on the material

### + Step 1

#### Remove rough scratch marks using the PREMIUM\*\*\* CONDITIONING disc.

It removes all rough scratch marks from the surfaces to be machined.

A multi-dimensional flap design reduces clogging and prevents unwanted material discolouration.

**Recommendation:** "Medium" grain



### + Step 2

#### Prepare for polishing with the PREMIUM\*\*\* PRE-POLISH disc

This provides optimum polishing preparation. The disc adapts flexibly to the material surface.

**Recommendation:** "Fine-P" grain

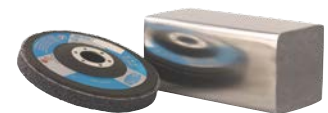

### + Step 3

#### Polish with the PREMIUM\*\*\* POLISH disc

This allows you finally to achieve a perfect mirror finish.

Different grinding pastes enable processing of different materials, such as steel, stainless steel and nonferrous metals.

**Recommendation:** SHF with "S-POLISH" polishing paste



**PREMIUM\*\*\* CONDITIONING**

For steel and stainless steel



With the PREMIUM\*\*\* CONDITIONING wheel you can remove all rough scratch marks from the surface before commencing the polishing process. The three-dimensional flap design reduces clogging of the wheel to a minimum. Using the wheel also prevents discolouration on the workpiece caused by high heat build-up.

The tool has been specially developed to achieve the best results even on non-adjustable angle grinders.

	Shape	Type no.	Dimension	Specification	PU	Max. RPM	
		28PCA	742155	115x22.23	COARSE	5	12,000
			742157	115x22.23	MEDIUM	5	12,000
			742158	115x22.23	VERY FINE	5	12,000
			742148	125x22.23	COARSE	5	11,000
			742153	125x22.23	MEDIUM	5	11,000
			742154	125x22.23	VERY FINE	5	11,000

**PREMIUM\*\*\* PRE-POLISH**

For steel and stainless steel



To prepare surfaces for polishing, you require a sturdy, high-quality tool. The PREMIUM\*\*\* PRE-POLISH comprises several layers of abrasive fabric to achieve a long lifetime and sturdiness. This allows the tool to be used for smaller deburring jobs as well.

The tool has been specially developed to achieve the best results even on non-adjustable angle grinders.

	Shape	Type no.	Dimension	Specification	PU	Max. RPM	
		28PUA	742379	115x22.23	MEDIUM-Q	5	12,000
			742380	115x22.23	FINE-P	5	12,000
			742381	115x22.23	VERY FINE-P	5	12,000
			742382	125x22.23	MEDIUM-Q	5	11,000
			742384	125x22.23	FINE-P	5	11,000
			742385	125x22.23	VERY FINE-P	5	11,000

**PREMIUM\*\*\* POLISH**

Universal use



Compared to conventional felt wheels, this product uses highly flexible flaps for optimum heat distribution and cool grinding. In doing so, the PREMIUM\*\*\* POLISH avoids undesired discolouration. Used in combination with the TYROLIT grinding paste, a perfect mirror finish is achieved on your workpiece.

The tool has been specially developed to achieve the best results even on non-adjustable angle grinders.

	Shape	Type no.	Dimension	Specification	PU	Max. RPM	
		28PWA	742378	115x22.23	SHF	3	9,200
			742375	125x22.23	SHF	3	7,700

**PREMIUM\*\*\* POLISHING PASTES**  
For steel, stainless steel and nonferrous metals



With the TYROLIT PREMIUM\*\*\* polishing paste in different specifications you will achieve the final mirror finish. They can be used to perform precision machining work depending on the desired surface finish.

Polishing pastes are available in three specifications. Using the POLISH (white), you will achieve a perfectly smooth finish. A achieve a high-gloss finish we recommend S-POLISH (blue) while the POLISH-NE paste is perfect for nonferrous metals.

		Type no.	Dimension	Specification	Colour	PU
	90PP	741230	30x20x90	POLISH	WHITE	2
		741285	30x20x90	POLISH-NE	BROWN	2
		741291	30x20x90	S-POLISH	BLUE	2
		741347	60x45x160	POLISH	WHITE	1
		741348	60x45x160	POLISH-NE	BROWN	1
		741349	60x45x160	S-POLISH	BLUE	1

# PREMIUM\*\*\* POLISHING PROGRAM

## THREE STEPS TO A MIRROR FINISH

**+ Step 1**

Remove rough scratch marks using the PREMIUM\*\*\* CONDITIONING disc. A multi-dimensional flap design reduces clogging and prevents unwanted material discolouration.

**+ Step 2**

Prepare the surface for polishing using the PREMIUM\*\*\* PRE-POLISH. The disc adapts to the material surface, providing the perfect basis for polishing.



**+ Step 3**

Using PREMIUM\*\*\* POLISH during the last step creates the perfect mirror finish. Different grinding pastes enable the machining of different materials.

**TYROLIT Film**



The product film can be found on YouTube at [www.youtube.com/TYROLITgroup](http://www.youtube.com/TYROLITgroup)

With the TYROLIT POLISHING PROGRAM you can achieve the perfect high gloss surface in just a few steps. Preventing clogging of the wheels

provides an above-average lifetime. Exceptionally cool grinding due to special flaps ensures outstanding surface finishes.

Exceptionally high levels of work safety due to low heat build-up, minimal formation of dust and quiet operation.

**PREMIUM★★★ POLISHING PROGRAM**

Three steps to a mirror finish



With the TYROLIT POLISHING PROGRAM you can achieve the perfect high gloss surface in just a few steps. Preventing clogging of the wheels provides an above-average lifetime. Exceptionally cool grinding due to special flaps ensures outstanding surface finishes.

Exceptionally high levels of work safety due to low heat build-up, minimal formation of dust and quiet operation.

	Type no.	Shape	Dimension	Specification	Type no.	PU
	21262	28PCA	115x22.23	MEDIUM	742157	1
		28PUA	115x22.23	FINE-P	742380	1
		28PWA	115x22.23	SHF	742378	1
		90 PP	30x20x90	S-POLISH	741291	2
	52433	28PCA	125x22.23	MEDIUM	742153	1
		28PUA	125x22.23	FINE-P	742384	1
		28PWA	125x22.23	SHF	742375	1
		90 PP	30x20x90	S-POLISH	741291	2

**PREMIUM★★★ POLISTAR**

For stone



These Velcro fastenable ceramic polishing pads are ideal for polishing stone surfaces. The grit sizes available in the assortment, from 50 to 3000, ensure a perfect surface finish on the material.

With the PREMIUM\*\*\* POLISTAR pads, you can achieve the best results on granite, marble and terrazzo.

	Type no.	Dimension	Specification	Colour	PU	
	65A	293641	100x3	D50-B	BLACK	5
		293643	100x3	D150-B	GREEN	5
		293644	100x3	D300-B	RED	5
		293645	100x3	D500-B	BLUE	5
		293737	100x3	D1000-B	YELLOW	5
		293738	100x3	D2000-B	BEIGE	5
		293739	100x3	D3000-B	WHITE	5
	ELKUPS	293790	100x3xM14			1



**PREMIUM\*\*\* POLISTAR-SET**  
For stone



These Velcro fastenable ceramic polishing pads are ideal for polishing stone surfaces. With the POLISTAR set, you receive 7 pads in grit sizes of 50, 150, 300, 500, 1000, 2000 and 3000, as well as a supporting disc with an M14 mounting.

With the PREMIUM\*\*\* POLISTAR pads, you can achieve the best results on granite, marble and terrazzo.

	Type no.	Contents	Dimension	PU
	293740	293641	100x3	1
		293643	100x3	1
		293644	100x3	1
		293645	100x3	1
		293737	100x3	1
		293738	100x3	1
		293739	100x3	1
		293790	100x3xM14	1

**STANDARD\*\* ELASTIC RONDELLER®**  
For steel and stainless steel



With the ELASTIC RONDELLER® TYROLIT provides an ideal tool for polishing and finishing. Thanks to the highly elastic grinding layer a surface improvement is achieved while protecting the material. Using a fibre glass core means it can be used on speed-controlled angle grinders.

Ideally suited to work on vehicles, containers and aeroplanes.

	Shape	Type no.	Dimension	Specification	PU	Max. RPM
		29EL	10055	115x9.0x22.23	A80-COARSE	5 5,000
			10056	115x9.0x22.23	A150-MEDIUM	5 5,000
			10058	115x9.0x22.23	A240-FINE	5 5,000

**STANDARD\*\* ELASTIC RONDELLER®**  
For lacquers, paints and plastics



Thanks to the highly elastic grinding layer the TYROLIT ELASTIC RONDELLER® delivers a surface improvement while protecting the material. This tool is therefore ideal for polishing and finishing. The specially developed specification delivers the best results on lacquers, paints and plastics.

Using a fibre glass core means it can be used on speed-controlled angle grinders. Ideally suited to work on vehicles, containers and aeroplanes.

	Shape	Type no.	Dimension	Specification	PU	Max. RPM
		29EL	8434	115x9.0x22.23	C80-COARSE	5 5,000
			10051	115x9.0x22.23	C150-MEDIUM	5 5,000
			10054	115x9.0x22.23	C240-FINE	5 5,000

Coated abrasives





## **4.3 ROUGH CLEANING WHEEL ANGLE GRINDER**





## ROUGH CLEANING WHEEL ANGLE GRINDER

Working with an angle grinder is one of the most important processes in the trade and industrial sectors for processing all types of metals. Would you like to remove rust, paint and varnish with a minimum of effort? Or do you need to prepare surfaces for welding, soldering or anodising?

The highly porous nylon fibres are evenly treated with aggressive abrasives and are able to meet any

challenge.

All of our rough cleaning discs resist loading or smearing and offer long

life with an even grinding pattern, but also low heat generation and quiet, stress-free working.



## Application recommendations



Performance Level	Specification	Pages	Steel	Stainless steel	Plastic
<b>STANDARD★★</b>	C36-B	193	●	●	●

Items with grey lettering are only available on request.

## Shapes

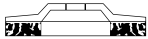

**27GR** Rough cleaning wheel  
(sound insulated)

### **STANDARD★★** ROUGH CLEANING WHEEL (SOUND INSULATED) For steel, stainless steel and PVC



With the TYROLIT rough cleaning wheel you can effortlessly remove rust, paint, lacquer and underbody sealant from your workpiece. The porous nylon fibres, treated with aggressive abrasives, meet any challenge. At the same time, they prevent clogging or loading.

This wheel offers the user quiet, non-strenuous grinding coupled with low generation of heat.

Shape	Type no.	Dimension	Specification	PU	Max. RPM	Rec. speed
	898012	100x22.23	C36-B	5	12,400	9,900
	898014	115x22.23	C36-B	5	11,000	8,600
	898017	125x22.23	C36-B	5	9,800	7,800
	898018	178x22.23	C36-B	5	7,000	6,600







**4.4 FIBRE DISCS**  
ANGLE GRINDER





## FIBRE DISCS ANGLE GRINDER

For quite a number of years, in the 'coated abrasives' range, TYROLIT has offered fibre discs and back up pads for all common and not-so-common grinding jobs.

Fibre discs are used when it is necessary to carry out rough grinding or derust or deburr surfaces. TYROLIT believes in the importance of flexibility and ease of use, and offers a very wide assortment for every conceivable application. Naturally the discs



come with all accessories needed for assembly.



TYROLIT has also developed a more environment-friendly version. Our JUTE DISC, made from eco-friendly jute fibre, is used without any





additional core and, being trimmable, offers maximum stock removal right to the very end. Try it for yourself!



## Application recommendations

Performance Level	Specification	Pages			
			Steel	Stainless steel	NF metals
<b>PREMIUM***</b>	A-P02 V	205	•		•
	ZA-P43 V	200	•		
	ZA-P43 N	198	•		•
	ZA-P48 V	201-202	•	•	
	ZA-P48 N	198	•	•	
	CA-P93 V	203-204	•	•	
	CA-P93 N	199	•	•	

Performance Level	Specification	Pages			
			Steel	NF metals	Wood
<b>BASIC*</b>	A-B02 V	205-206	•	•	•

Performance Level	Specification	Pages				
			Steel	NF metals	Composites	Gel coat
TFC	ZA-P45 V	207	•	•	•	•
<b>PREMIUM***</b>	ZA-P45 P F	207	•	•	•	•

Items with grey lettering are only available on request.

## Shapes



N JUTE disc



V Disc 4S  
Vulcanised fibre disc



TYROLIT  
Fast Change disc



PAD UNI back up pads



PAD INOX back up pads



PAD TFC back up pads  
for TYROLIT Fast Change



PAD BASIC  
back up pads



Coated abrasives

**PREMIUM★★★ ZA-P48N JUTE DISC**  
For steel and stainless steel



The TYROLIT JUTE disc is a new, unique grinding wheel that combines abrasiveness with a high level of comfort while working. This tool can be used on both steel and stainless steel. The longest lifetime and an environmentally friendly jute fibre core deliver the best performance. An additional back up pad is not required, as there is already one integrated

in the product. The natural fibre core can be trimmed, giving it the edge over other discs in terms of its lifetime. This saves the user time and great expense.



	Shape	Type no.	Diameter	Grain	Max. RPM	PU	
		N Disc	706128	115x22	36	13,300	10
			205056	115x22	60	13,300	10
			706129	125x22	36	12,250	10
			205058	125x22	60	12,250	10
			706130	180x22	36	8,600	10
			205060	180x22	60	8,600	10

**PREMIUM★★★ ZA-P43N JUTE DISC**  
For steel and nonferrous metals



The TYROLIT JUTE disc is a new, unique grinding wheel that combines abrasiveness with a high level of comfort while working. It achieves excellent results on both steel and nonferrous metals. The longest lifetime and an environmentally friendly jute fibre core deliver the best performance. An additional back up pad is not required, as there is already one integrated

in the product. The natural fibre core can be trimmed, giving it the edge over other discs in terms of its lifetime. This saves the user time and great expense.

	Shape	Type no.	Diameter	Grain	Max. RPM	PU	
		N Disc	706125	115x22	36	13,300	10
			706126	125x22	36	12,250	10
			706127	180x22	36	8,600	10

Coated abrasives

# PREMIUM★★★ CA-PA93 N JUTE DISC FOR STEEL AND STAINLESS STEEL

**+ Longest lifetime**  
Ceramic aluminium oxide and an additional coolant layer deliver maximum removal rates and the longest lifetime possible.

**+ Extremely high stock removal rate**  
The high abrasiveness of the JUTE DISC means it achieves the highest stock removal rates.



**+ Environmentally-friendly**  
The jute fibre core not only protects the environment, but also enables the disc to be trimmed.

**TYROLIT Film**



The product film can be found on YouTube at [www.youtube.com/TYROLITgroup](https://www.youtube.com/TYROLITgroup)



The TYROLIT JUTE disc is a new, unique grinding wheel that combines abrasiveness with a high level of comfort while working thanks to a ceramic grain. The longest lifetime and an environmentally friendly jute

fibre core deliver the best performance. An additional back up pad is not required, as there is already one integrated in the product. The natural fibre core can be trimmed, giving it the edge over

other discs in terms of its lifetime. This saves the user time and great expense.

**PREMIUM★★★ CA-P93 N JUTE DISC**  
For steel and stainless steel



	Shape	Type no.	Diameter	Grain	Max. RPM	PU	
		N Disc	712268	115x22	36	13,300	10
			712259	125x22	36	12,250	10
			712269	180x22	36	8,600	10

Coated abrasives

**ACCESSORIES****JUTE DISC**

With a large distance between the disc and machine, you can machine even surfaces at a low grinding angle. Use our PREMIUM\*\*\* JUTE disc accessories to achieve this. The accessories are compatible with all disc diameters.



	Shape	Type no.	Diameter	Mounting	Max. RPM	PU
	100SFL	21381	42x22.23	M14	13,300	1

**PREMIUM\*\*\* ZA-P43 V VULCANISED FIBRE DISCS**

For steel



Using fibre discs is a very simple and quick solution for removing material. This fibre disc is available from our assortment in grit sizes 24 to 120. A low level of vibration means the tools are convenient to use. This fibre disc has been designed for use on steel and is made of a zirconium aluminium oxide mix.

	Shape	Type no.	Diameter	Grain	Max. RPM	PU
	 V Disc	706068	115x22	24	13,300	25
		706069	115x22	36	13,300	25
		706071	115x22	40	13,300	25
		706072	115x22	60	13,300	25
		706073	115x22	80	13,300	25
		706074	115x22	120	13,300	25
		706075	125x22	24	12,300	25
		706076	125x22	36	12,300	25
		706077	125x22	40	12,300	25
		706078	125x22	60	12,300	25
		706079	125x22	80	12,300	25
		706082	125x22	120	12,300	25
		706084	180x22	24	8,600	25
		706088	180x22	36	8,600	25
		706089	180x22	40	8,600	25
706090	180x22	60	8,600	25		
706091	180x22	80	8,600	25		
706092	180x22	120	8,600	25		



# PREMIUM★★★ ZA-P48 V VULCANISED FIBRE DISCS FOR STEEL AND STAINLESS STEEL

+ **Longest lifetime**  
Resistant zirconium aluminium oxide and a coolant layer deliver maximum removal rates and the longest lifetime.

+ **Maximum economic efficiency**  
Excellent price-performance ratio

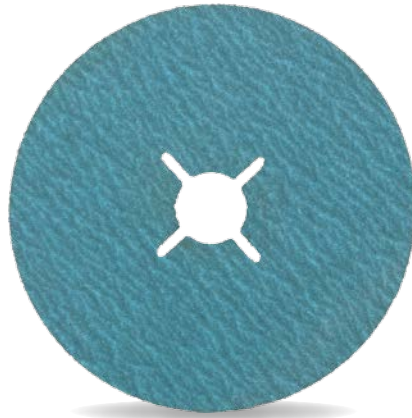

+ **Very good finish**  
To achieve the best possible surface finish, the backing thickness has been optimised, particularly for fine grains.



Using fibre discs is a very simple and quick solution for removing material. A low level of vibration means the tools are convenient to use. This fibre

disc has been designed for use on steel and stainless steel, and is made of a zirconium aluminium oxide mix.

This fibre disc is available from our assortment in grit sizes 36 to 120.

## PREMIUM★★★ ZA-P48 V VULCANISED FIBRE DISCS For steel and stainless steel





	Shape	Type no.	Diameter	Grain	Max. RPM	PU	
		V Disc	34162979	115x22	24	13,300	25
		34162980	115x22	36	13,300	25	
		34162981	115x22	40	13,300	25	
		34162982	115x22	60	13,300	25	
		34162983	115x22	80	13,300	25	
		34162985	115x22	120	13,300	25	
		34162987	125x22	24	12,300	25	
		34162988	125x22	36	12,300	25	
		34162989	125x22	40	12,300	25	
		34162990	125x22	60	12,300	25	
		34163011	125x22	80	12,300	25	
		34163012	125x22	120	12,300	25	

**PREMIUM\*\*\* ZA-P48 V VULCANISED FIBRE DISCS**

For steel and stainless steel



	Shape	Type no.	Diameter	Grain	Max. RPM	PU
		34163013	180x22	24	8,600	25
		34163014	180x22	36	8,600	25
		34163015	180x22	40	8,600	25
		34163020	180x22	60	8,600	25
		34163021	180x22	80	8,600	25
		34163022	180x22	120	8,600	25
		34163024	115x22	24	13,300	50
		34163025	115x22	36	13,300	50
		34163026	115x22	40	13,300	50
		34163888	115x22	60	13,300	50
		34163889	115x22	80	13,300	50
		34163890	115x22	120	13,300	50
		34163902	125x22	24	12,300	50
		34163903	125x22	36	12,300	50
		34163905	125x22	40	12,300	50
		34163906	125x22	60	12,300	50
		34163908	125x22	80	12,300	50
34163910	125x22	120	12,300	50		
34163911	180x22	24	8,600	50		
34163912	180x22	36	8,600	50		
34163913	180x22	40	8,600	50		
34163914	180x22	60	8,600	50		
34163915	180x22	80	8,600	50		
34163917	180x22	120	8,600	50		

Coated abrasives

# PREMIUM★★★ CA-P93 V VULCANISED FIBRE DISCS FOR STEEL AND STAINLESS STEEL

**+ Maximum abrasiveness**

Ceramic aluminium oxide delivers maximum removal rates and the longest lifetime.

**+ Longest lifetime**

An additional layer of active coolants increases the lifetime and reduces heat build-up while grinding is performed on different materials.

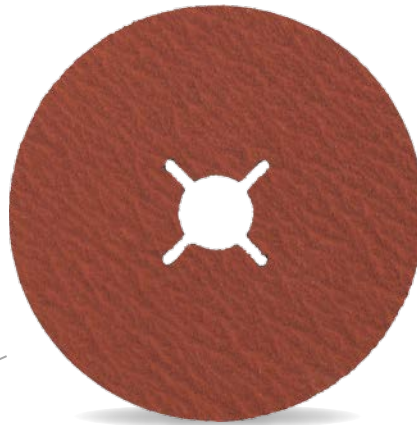

**+ Strong backing**

The 0.86 mm thick backing holds the grain in place, thus ensuring maximum abrasiveness.

Using fibre discs is a very simple and quick solution for removing material. A low level of vibration means the tools are convenient to use. This fibre

disc has been designed for use on steel and stainless steel, and is made of a ceramic aluminium oxide mix.

This fibre disc is available from our assortment in grit sizes 36 to 120.

**PREMIUM★★★ CA-P93 V VULCANISED FIBRE DISCS**

For steel and stainless steel





	Shape	Type no.	Diameter	Grain	Max. RPM	PU	
		V Disc	34163955	115x22	24	13,300	25
		706107	115x22	36	13,300	25	
		34163957	115x22	40	13,300	25	
		706108	115x22	60	13,300	25	
		706109	115x22	80	13,300	25	
		706110	115x22	120	13,300	25	
		34163958	125x22	24	12,300	25	
		706111	125x22	36	12,300	25	
		34163959	125x22	40	12,300	25	
		706114	125x22	60	12,300	25	
		706116	125x22	80	12,300	25	
		706117	125x22	120	12,300	25	

**PREMIUM★★★ CA-P93 V VULCANISED FIBRE DISCS**

For steel and stainless steel





	Shape	Type no.	Diameter	Grain	Max. RPM	PU	
		V Disc	34164002	180x22	24	8,600	25
			706119	180x22	36	8,600	25
			34164004	180x22	40	8,600	25
			706120	180x22	60	8,600	25
			706123	180x22	80	8,600	25
			706124	180x22	120	8,600	25
			34163992	115x22	24	13,300	50
			34163993	115x22	36	13,300	50
			34163994	115x22	40	13,300	50
			34163995	115x22	60	13,300	50
			34163997	115x22	80	13,300	50
			34163998	115x22	120	13,300	50
			34163999	125x22	24	12,300	50
			34164000	125x22	36	12,300	50
			34164011	125x22	40	12,300	50
			34164012	125x22	60	12,300	50
			34164013	125x22	80	12,300	50
			34164014	125x22	120	12,300	50
			34164015	180x22	24	8,600	50
			34164017	180x22	36	8,600	50
34164018	180x22	40	8,600	50			
34164019	180x22	60	8,600	50			
34164020	180x22	80	8,600	50			
34164031	180x22	120	8,600	50			



**PREMIUM★★★ A-P02 V VULCANISED FIBRE DISCS**  
For steel and aluminium





Using fibre discs is a very simple and quick solution for removing material. This fibre disc is available from our assortment in grit sizes 24 to 120. A low level of vibration means the tools are convenient to use. This fibre disc has been designed for general use and is made of an aluminium oxide mix. It can be used for outstanding results on steel and nonferrous metals.

	Shape	Type no.	Diameter	Grain	Max. RPM	PU	
		V Disc	706049	115x22	24	13,300	25
		706050	115x22	36	13,300	25	
		706051	115x22	40	13,300	25	
		706052	115x22	60	13,300	25	
		706053	115x22	80	13,300	25	
		706054	115x22	120	13,300	25	
		706055	125x22	24	12,300	25	
		706056	125x22	36	12,300	25	
		706057	125x22	40	12,300	25	
		706058	125x22	60	12,300	25	
		706059	125x22	80	12,300	25	
		706060	125x22	120	12,300	25	
		706061	180x22	24	8,600	25	
		706063	180x22	36	8,600	25	
		706064	180x22	40	8,600	25	
		706065	180x22	60	8,600	25	
		706066	180x22	80	8,600	25	
706067	180x22	120	8,600	25			

**BASIC★ A-B02 V VULCANISED FIBRE DISCS**  
For steel, aluminium and wood



Using fibre discs is a very simple and quick solution for removing material. This fibre disc is available from our assortment in grit sizes 16 to 120. A low level of vibration means the tools are convenient to use. This fibre disc has been designed for universal use and is made of an aluminium oxide mix.

	Shape	Type no.	Diameter	Grain	Max. RPM	PU	
		V Disc	150465	115x22	16	13,300	25
		706024	115x22	24	13,300	25	
		706025	115x22	36	13,300	25	
		706026	115x22	40	13,300	25	
		706027	115x22	60	13,300	25	

**BASIC★ A-B02 V VULCANISED FIBRE DISCS**

For steel, aluminium and wood



Using fibre discs is a very simple and quick solution for removing material. This fibre disc is available from our assortment in grit sizes 16 to 120. A low level of vibration means the tools are convenient to use. This fibre disc has been designed for universal use and is made of an aluminium oxide mix.

	Shape	Type no.	Diameter	Grain	Max. RPM	PU
	V Disc	706028	115x22	80	13,300	25
		150467	115x22	100	13,300	25
		706029	115x22	120	13,300	25
	150468	125x22	16	12,300	25	
	706030	125x22	24	12,300	25	
	706031	125x22	36	12,300	25	
	706032	125x22	40	12,300	25	
	706033	125x22	60	12,300	25	
	706034	125x22	80	12,300	25	
	150469	125x22	100	12,300	25	
	706035	125x22	120	12,300	25	
	150473	180x22	16	8,600	25	
	706036	180x22	24	8,600	25	
	706037	180x22	36	8,600	25	
	706038	180x22	40	8,600	25	
	706039	180x22	60	8,600	25	
	706047	180x22	80	8,600	25	
	706048	180x22	120	8,600	25	

**ACCESSORIES**

For FIBRE DISCS



With our PREMIUM\*\*\* back up pads you will obtain the best support for the highest demands. Regardless of whether you choose a hard or very hard backing, you can influence the stock removal rate on the workpiece.

Thanks to the special design, you will benefit from constant air circulation, preventing heat build-up on the workpiece and the tool.

	Shape	Type no.	Diameter	Mounting	Grade	Max. RPM	PU
	PAD INOX	709989	115x22	M14	VERY HARD	13,300	5
		709991	125x22	M14	VERY HARD	12,300	5
	PAD UNI	709992	115x22	M14	HARD	13,300	5
		709993	125x22	M14	HARD	12,300	5
		709994	180X22	M14	HARD	8,600	5

## ACCESSORIES

For FIBRE DISCS



The BASIC\* back up pad is a good supplement to all our fibre discs. The accessories offer good support in achieving the best results for the surface finish.

	Shape	Type no.	Diameter	Mounting	Grade	Max. RPM	PU	
		PAD BASIC	709995	115x22	M14	HARD	13,300	5
		709997	125x22	M14	HARD	12,300	5	
		709998	180X22	M14	HARD	8,600	5	
		709999	115x22	5/8"	HARD	13,300	5	
		710002	125x22	5/8"	HARD	12,300	5	
		710005	180X22	5/8"	HARD	8,600	5	

## PREMIUM\*\*\* ZA-P45\* | ZA-P45 P F TYROLIT FAST CHANGE

For steel, nonferrous metals, composites and gel coat



TYROLIT FAST CHANGE enables you to change a disc very quickly thanks to the Velcro fastening. The TFC grinding wheel, developed for steel and other material grinding and finishing, is made of zirconium with active coolants. This enables cool, clean grinding to be performed on the workpiece.

Thanks to the thin fibre backing with grit 40 and strong paper backing the TFC is the optimal tool for removing smaller welding and spot weld seams.

	Shape	Type no.	Diameter	Grain	Max. RPM	PU	
		Disc	706135*	115	40	12,300	50
		706136	115	60	12,300	50	
		706137	115	80	12,300	50	
		706138	115	120	12,300	50	
		706139*	125	40	10,500	50	
		706141	125	60	10,500	50	
		706142	125	80	10,500	50	
		706143	125	120	10,500	50	

\* Fibre backing

## PREMIUM\*\*\* ACCESSORIES

For TYROLIT FAST CHANGE



The TFC back up pad has been developed to allow grinding wheels with Velcro fastenings to be used for grinding tougher materials and for finishing. The high-quality product design enables it to be used on different

materials, including wood and paints. The back up pad is characterised by easy handling and mounting on speed-controlled angle grinders.

	Shape	Type no.	Diameter	Mounting	Grade	Max. RPM	PU	
		PAD TFC	710006	115	M14	HARD	13,300	5
		710007	125	M14	HARD	12,300	5	







GWS 14-125 CIT  
Professional

**4.5 SCM - SURFACE  
CONDITIONING MATERIAL  
ANGLE GRINDER**

Coated  
abrasives





## SCM DISCS FOR ANGLE GRINDERS

Working with an angle grinder is one of the most important processes in the trade and industrial sectors for processing all types of metals. TYROLIT now offers the SCM product assortment for use with angle grinders as well.

Surface Conditioning Material discs combine excellent cutting ability with long tool life, so that you can achieve optimum surface quality. This saves you two or three work steps. From simple deburring work without workpiece deformation to perfect

surface finishing, SCM can be used universally.

With a wide range of grain sizes, from extra coarse to very fine, TYROLIT products are suitable for many different applications. Our discs offer

another special feature: thanks to the removable centre hole, our discs can be mounted on the three most popular back up pads. Try it for yourself!

# Application recommendations



Performance level	Specification	Pages	All in One
<b>PREMIUM★★★</b>	Extra coarse, coarse, Extra medium, medium, very fine	212-213	<span style="color: blue;">●</span>

Items with grey lettering are only available on request.

## SCM disc assembly

SCM discs are designed for use on an angle grinder and are available in the popular diameters 115 – 178 mm, from extra coarse to very fine.

**Cleverly designed:** Thanks to the removable centre hole, each of these discs can be used on all three of the supporting discs in our range.

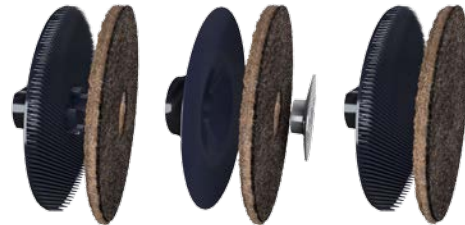

Coated abrasives

## Colours

	Extra coarse	Coarse	Extra Medium	Medium	Very fine
Front					
Back					

## Shapes



DISC SCM disc

# PREMIUM★★★ SCM

## UNIVERSAL USE

### + Reduces working times

The working time is significantly reduced through the long lifetime and the saving of one to three work steps.

### + Noticeable cost reduction

Fewer work steps also means reduced tool costs.



### + One disc, three options

Thanks to the removable centre hole, this disc can also be mounted on three different back up pads.

With the new TYROLIT SCM program, we are now taking a further step towards economic efficiency. With SCM, the machining time of the workpiece can now be greatly reduced. A saving of one to three work steps is thus the key benefit.

Thanks to the quick and high stock removal rate, applications such as the reduction of surface roughness, removal of discolouration, smoothing of surfaces and the cleaning and removal of weld seams can be realised. Another advantage of SCM lies in the

deburring of tool edges without additional stock removal. Furthermore, the TYROLIT SCM program is yielding the best results in terms of lifetime, which in turn is evidence of the economic efficiency of these products.



## PREMIUM★★★ SCM

### Universal use



Shape	Type no.	Dimension	Design	Colour	Max. RPM	Rec. RPM	PU	
 	Disc	34047714	115x22	EXTRA COARSE	DARK BROWN / PURPLE	13,000	8-9,000	20
	34047715	115x22	COARSE	BROWN		13,000	8-9,000	20
	34047716	115x22	EXTRA MEDIUM	DARK BROWN / PURPLE		13,000	8-9,000	20
	34047720	115x22	MEDIUM	RED		13,000	8-9,000	20
	34047722	115x22	VERY FINE	BLUE		13,000	8-9,000	20
	34047724	125x22	EXTRA COARSE	DARK BROWN / PURPLE		12,000	7-8,500	20
	34047727	125x22	COARSE	BROWN		12,000	7-8,500	20
	34047730	125x22	EXTRA MEDIUM	DARK BROWN / PURPLE		12,000	7-8,500	20
	34047732	125x22	MEDIUM	RED		12,000	7-8,500	20
	34047733	125x22	VERY FINE	BLUE		12,000	7-8,500	20



	Shape	Type no.	Dimension	Design	Colour	Max. RPM	Rec. RPM	PU
		Disc 34047734	178x22	EXTRA COARSE	DARK BROWN / PURPLE	8,500	5-6,000	20
		34047735	178x22	COARSE	BROWN	8,500	5-6,000	20
		34047736	178x22	EXTRA MEDIUM	DARK BROWN / PURPLE	8,500	5-6,000	20
		34047755	178x22	MEDIUM	RED	8,500	5-6,000	20
		34047757	178x22	VERY FINE	BLUE	8,500	5-6,000	20



**PREMIUM★★★ ACCESSORIES**

For SCM discs



The intelligent design of our SCM discs enables them to be used on all the back up pads available in our assortment. The removable centre hole of the SCM disc enables the disc to be fitted to the back up pad in a self-centring position.

The discs and back up pads are designed for use on the angle grinder in all common diameters from 115 to 178 mm.

	Shape	Type no.	Diameter	Mounting	Grade	Max. RPM	PU
		PAD SCM 34050524	115x22	M14	MEDIUM	13,000	1
		34050525	125x22	M14	MEDIUM	12,000	1
		34050358	115	M14	MEDIUM	13,000	1
		34050359	125	M14	MEDIUM	12,000	1
		34050509	178	M14	MEDIUM	8,500	1







## **4.6 QUICK-CHANGE DISCS** MINI ANGLE GRINDER

Coated  
abrasives





## QUICK CHANGE DISCS MINI ANGLE GRINDER

Quick Change Discs are easy to use, without assembly tools being required. Easy handling on the mini angle grinder saves you a lot of time in your day-to-day work and increases your productivity.

A comprehensive assortment offers high-quality products for general grinding work, including fine surface finishing.

Two different mountings cover the main fixing systems. Type R can be used for Lockit, PowerLock III and





Roloc TR mountings, type S for So-cAtt, PowerLock II and Roloc TSM.





Another special feature of the S type mounting is that it is made from nylon, making it immune to rust and other types of contamination.



TYROLIT offers Quick Change Discs in a wide range of grit sizes for different materials. Take a look at our wide-ranging assortment and see for yourself.



## Application recommendations

Performance Line	Specification	Pages	    				
			Steel	Stainless steel	NF metals	PVC	Wood
QUICK-CHANGE DISCS <b>PREMIUM</b> ★★★	A-P01 PE Y	221	•		•	•	•
	ZA-P43 PC X	218	•				
	ZA-P48 PE Y	219	•	•			
	CA-P93 PE Y	220-221	•	•			

Performance Line	Pages	    				
		Steel	Stainless steel	NF metals	PVC	Wood
SCM QUICK-CHANGE DISCS <b>PREMIUM</b> ★★★	222	•	•	•	•	•

Performance Line	Pages	  		
		Steel	Stainless steel	PVC
ROUGH GRINDING WHEEL <b>PREMIUM</b> ★★★	223	•	•	•

Items with grey lettering are only available on request.

## Formen



QDisc-R



QDisc-S



Pad Q-Disc

Coated abrasives



**PREMIUM★★★ ZA-P43 PC X QUICK-CHANGE DISC**

For steel



With TYROLIT QUICK CHANGE DISCS you can save time and thus increase productivity. They provide easy handling and can be used without the need for any additional mounting tools. These QUICK CHANGE DISCS are specially designed for general grinding tasks on steel.

Our two different types cover the main mounting systems.

	Shape	Type no.	Diameter	Grain	Max. RPM	PU
	 QDisc-R	116061	50	36	25,000	50
		116065	50	40	25,000	50
		116097	50	60	25,000	50
		116111	50	80	25,000	50
		116115	50	120	25,000	50
		116127	75	36	20,000	25
		116130	75	40	20,000	25
		116143	75	60	20,000	25
		116152	75	80	20,000	25
		116156	75	120	20,000	25

## PREMIUM★★★ ZA-P48 PE Y QUICK-CHANGE DISC FOR STEEL AND STAINLESS STEEL

### + Maximum stock removal rates

Thanks to its high level of abrasiveness, you can achieve high stock removal on the workpiece.

### + Longest lifetime

The robust three-layer design and reduced grain break-out make this a durable and efficient tool.

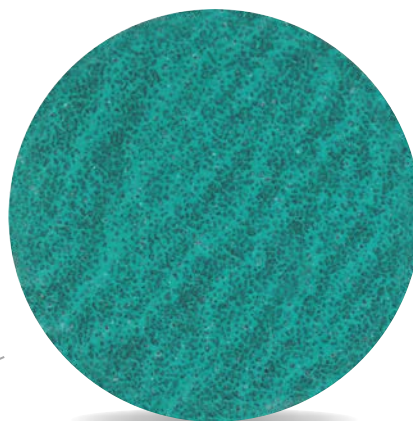

### + Broad assortment

The discs are available in two diameters with different mounting types. Grit sizes 36 to 120 are suitable for all grinding tasks.



With TYROLIT QUICK CHANGE DISCS you can save a considerable amount of time. This specification delivers maximum stock removal rates

at the same time as a long lifetime. This is achieved by combining the zirconium and ceramic aluminium oxide with a three-layer product structure.

In addition, this product also delivers a high level of stability, low grain break-out and enhanced edge stability.

**PREMIUM\*\*\* ZA-P48 PE Y QUICK-CHANGE DISC**  
 For steel and stainless steel



Shape	Type no.	Diameter	Grain	Max. RPM	PU	
	 QDisc-R	112398	50	24	25,000	50
		112401	50	36	25,000	50
		112406	50	40	25,000	50
		112411	50	60	25,000	50
		112413	50	80	25,000	50
		112418	50	120	25,000	50
		112432	75	24	20,000	25
		112438	75	36	20,000	25
		112440	75	40	20,000	25
		112447	75	60	20,000	25
		112449	75	80	20,000	25
		112452	75	120	20,000	25
 QDisc-S	112455	50	24	25,000	50	
	112469	50	36	25,000	50	
	112471	50	40	25,000	50	
	112486	50	60	25,000	50	
	112493	50	80	25,000	50	
	112494	50	120	25,000	50	
	112505	75	24	20,000	25	
	112510	75	36	20,000	25	
	112514	75	40	20,000	25	
	112527	75	60	20,000	25	
	112532	75	80	20,000	25	
	112536	75	120	20,000	25	

Coated abrasives

# PREMIUM★★★ CA-P93 PE Y QUICK-CHANGE DISC FOR STEEL AND STAINLESS STEEL

## + Maximum stock removal rates

Thanks to its high level of abrasiveness, you can achieve high stock removal on the workpiece.

## + Longest lifetime

The robust three-layer design and reduced grain break-out make this a durable and efficient tool.



## + Broad assortment

The discs are available in two diameters with different mounting types. Grit sizes 36 to 120 are suitable for all grinding tasks.

With TYROLIT QUICK CHANGE DISCS you can save a considerable amount of time. This specification delivers maximum stock removal rates



at the same time as a long lifetime. This is achieved by combining the zirconium and ceramic aluminium oxide with a three-layer product structure.

In addition, this product also delivers a high level of stability, low grain break-out and enhanced edge stability.



## PREMIUM★★★ CA-P93 PE Y QUICK-CHANGE DISC

For steel and stainless steel



	Shape	Type no.	Diameter	Grain	Max. RPM	PU	
		QDisc-R	112917	50	36	25,000	50
		112918	50	40	25,000	50	
		112923	50	60	25,000	50	
		112924	50	80	25,000	50	
		112928	50	120	25,000	50	
		112934	75	36	20,000	25	
		112935	75	40	20,000	25	
		112937	75	60	20,000	25	
		112947	75	80	20,000	25	
		112948	75	120	20,000	25	



	Shape	Type no.	Diameter	Grain	Max. RPM	PU	
		QDisc-S	112950	50	36	25,000	50
		112961	50	40	25,000	50	
		112988	50	60	25,000	50	
		113007	50	80	25,000	50	
		113023	50	120	25,000	50	
		113026	75	36	20,000	25	
		113027	75	40	20,000	25	
		113031	75	60	20,000	25	
		113057	75	80	20,000	25	
		113059	75	120	20,000	25	



**PREMIUM★★★ A-PO1 PE Y QUICK-CHANGE DISC**

For steel, nonferrous metals, plastic and wood



With TYROLIT QUICK CHANGE DISCS you can save time and increase productivity. They provide easy handling and can be used without the need for any additional mounting tools. Our QUICK CHANGE DISC assortment includes discs for general grinding tasks on any material.

Our two different types cover the main mounting systems.

	Shape	Type no.	Diameter	Grain	Max. RPM	PU	
		QDisc-R	111562	50	24	25,000	50
		111567	50	36	25,000	50	
		111570	50	40	25,000	50	
		111577	50	60	25,000	50	
		111584	50	80	25,000	50	
		111585	50	120	25,000	50	
		111611	75	24	20,000	25	
		111631	75	36	20,000	25	
		112203	75	40	20,000	25	
		112204	75	60	20,000	25	
		112205	75	80	20,000	25	
		112242	75	120	20,000	25	
			QDisc-S	112253	50	24	25,000
112254	50			36	25,000	50	
112268	50			40	25,000	50	
112273	50			50	25,000	50	
112279	50			60	25,000	50	
112283	50			80	25,000	50	
112298	50			120	25,000	50	
112308	50			180	25,000	50	
112309	75			24	20,000	25	

**PREMIUM\*\*\* A-PO1 PE Y QUICK-CHANGE DISC**  
 For steel, nonferrous metals, plastic and wood



With TYROLIT QUICK CHANGE DISCS you can save time and increase productivity. They provide easy handling and can be used without the need for any additional mounting tools. Our QUICK CHANGE DISC assortment includes discs for general grinding tasks on any material.

Our two different types cover the main mounting systems.

	Shape	Type no.	Diameter	Grain	Max. RPM	PU
		112312	75	36	20,000	25
		112320	75	40	20,000	25
		112322	75	50	20,000	25
		112337	75	60	20,000	25
		112339	75	80	20,000	25
		112359	75	120	20,000	25

# PREMIUM\*\*\* SCM QUICK-CHANGE DISC

## FOR STEEL, STAINLESS STEEL, NON-FERROUS METALS, PLASTIC AND WOOD

+ **Reduces working times**  
 The working time is significantly reduced through the long lifetime and the saving of one to three work steps.

+ **Noticeable cost reduction**  
 Fewer work steps also means reduced tool costs.



+ **Comprehensive assortment**  
 The SCM range currently includes discs in the most varied of sizes and specifications.

With the new TYROLIT SCM program, we are now taking a further step towards economic efficiency. Simple handling and mounting save you time. With SCM, the machining time of the workpiece can now be

greatly reduced. A saving of one to three work steps is thus the key benefit.

Thanks to the quick and high stock removal rate, applications such as



the reduction of surface roughness, removal of discolouration, smoothing of surfaces and the cleaning and removal of weld seams can be realised.

Coated abrasives

**PREMIUM★★★ SCM QUICK-CHANGE DISC**

For steel, stainless steel, nonferrous metals, plastic and wood

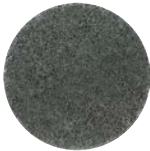

Shape	Type no.	Diameter	Design	Colour	Max. RPM	Rec. speed	PU	
	 QDisc-R	34072695	50	EXTRA COARSE	DARK BROWN / PURPLE	25,000	16,000	50
		112543	50	COARSE	BROWN	25,000	16,000	50
		34072696	50	EXTRA MEDIUM	DARK BROWN / PURPLE	25,000	16,000	50
		112546	50	MEDIUM	RED	25,000	16,000	50
		112550	50	VERY FINE	BLUE	25,000	16,000	50
		34072700	75	EXTRA COARSE	DARK BROWN / PURPLE	20,000	13,000	25
		112551	75	COARSE	BROWN	20,000	13,000	25
		34072701	75	EXTRA MEDIUM	DARK BROWN / PURPLE	25,000	13,000	25
		112581	75	MEDIUM	RED	20,000	13,000	25
		112588	75	VERY FINE	BLUE	20,000	13,000	25
	QDisc-S	112589	50	COARSE	BROWN	25,000	16,000	50
		112590	50	MEDIUM	RED	25,000	16,000	50
		112591	50	VERY FINE	BLUE	25,000	16,000	50
		112592	75	COARSE	BROWN	20,000	13,000	25
		112593	75	MEDIUM	RED	20,000	13,000	25
		112599	75	VERY FINE	BLUE	20,000	13,000	25



**PREMIUM★★★ ROUGH CLEANING WHEEL**

For steel, stainless steel and PVC



With the TYROLIT rough cleaning wheel for mini angle grinders you can effortlessly remove rust, paint, lacquer and underbody sealant. The porous nylon fibres, treated with aggressive abrasives, meet any challenge. At the same time, it prevents smearing and loading of the disc.

This wheel offers the user quiet, non-strenuous grinding coupled with low generation of heat.



Shape	Type no.	Diameter	Design	Colour	Max. RPM	Rec. speed	PU	
	 QDisc-R	112602	50	COARSE	BLACK	10,500	7,000	20
		112603	75	COARSE	BLACK	7,000	4,000	10

## PREMIUM★★★ ACCESSORIES

For QUICK-CHANGE DISCS



These accessories enable QUICK CHANGE DISCS to be easily and safely mounted on your mini angle grinder. The accessories are available in the common sizes of 50 and 75 mm diameter.

	Shape	Type no.	Dimension	Grade	Mounting	Max. RPM	PU
		PAD Q-DISC 131779	50-6x40	MEDIUM	R	25,000	1
		131783	75-6x40	MEDIUM	R	20,000	1
		131784	50-6x40	MEDIUM	S	25,000	1
		131786	75-6x40	MEDIUM	S	20,000	1



## STANDARD★★ QUICK-CHANGE MINIDISC

2in1 for steel and stainless steel



The STANDARD\*\* Minidisc was specially developed for machining and refining difficult to access places. Every disc is fitted with a quick fixing system which enables fast and convenient tool changes.

The MINIDISC is also a 2in1 rough grinding wheel and is therefore equally suitable for steel and stainless steel.

	Shape	Type no.	Diameter	Grain	Max. RPM	PU
		QDisc-R 679662	50	40	30,000	10
		666221	50	60	30,000	10
		679663	50	80	30,000	10
		679664	50	120	30,000	10
		666276	75	40	20,000	10
		666279	75	60	20,000	10
		666280	75	80	20,000	10
		666421	75	120	20,000	10





## STANDARD\*\* SOFTJOB

2in1 for steel and stainless steel



For us, the STANDARD\*\* SOFTJOB Q-Disc represents maximum flexibility for machining difficult to access areas. It has a broad application area, comprising: Surface preparation and improvement, preparation of welding work and cleaning of weld seams,

processing of contours and profiled surfaces, processing of handrails and pipes, cleaning of surfaces, removal of rust and paint residues.

	Shape	Type no.	Diameter	Grain	Max. RPM	PU	
		QDisc-R	246982	50	40	30,000	10
		246984	50	60	30,000	10	
		246985	50	80	30,000	10	
		246986	50	120	30,000	10	
		289327	75	40	20,000	10	
		289329	75	60	20,000	10	
		289330	75	80	20,000	10	







**4.7 SPIRAL BELTS**  
STRAIGHT GRINDER



## SPIRAL BELTS STRAIGHT GRINDER

Straight grinders are used when you need to work precisely in hard-to-reach locations. TYROLIT spiral belts provide the help you need for every task. They're precise, yet flexible.

Our spiral belts allow you to work quickly and neatly on every type of metal, both ferrous and nonferrous. Applications range from simple deburring, to precision work, to the shaping of complex workpieces.

With many different grit sizes available, a wide range of possibilities is open to you. Naturally TYROLIT also offers suitable accessories for easy assembly on straight grinders.



## Application recommendations



Performance Level	Specification	Pages	Steel	Stainless steel	NF metals
<b>PREMIUM</b> ★★★	ZA-P43 PC X	230-231	●	●	●

Items with grey lettering are only available on request.

## Shapes



Spiral Spiral belt

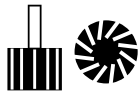

SBH Accessories



**PREMIUM★★★ ZA-P43 PC X SPIRAL BELTS**



For steel, stainless steel and aluminium



TYROLIT spiral belts are used for fine grinding and deburring work, as well as shaping complex workpieces. The combination of zirconium and an additional coolant enables them to be used on many different materials. The variety of grit sizes available means they can be used for very high stock removal or fine grinding.

The spiral belts can easily be mounted on an axle or an expandable mandrel. Accessories also form part of our assortment.

	Shape	Type no.	Dimension	Grain	Max. RPM	PU	
		Spiral	706514	10x20	50	36,000	50
		706515	10x20	60	36,000	50	
		706516	10x20	80	36,000	50	
		706517	10x20	120	36,000	50	
		706519	13x25	50	36,000	50	
		706520	13x25	60	36,000	50	
		706521	13x25	80	36,000	50	
		706523	13x25	120	36,000	50	
		706524	15x30	36	36,000	50	
		706525	15x30	50	36,000	50	
		706526	15x30	60	36,000	50	
		706527	15x30	80	36,000	50	
		706528	15x30	120	36,000	50	
		706529	19x25	36	30,000	50	
		706530	19x25	50	30,000	50	
		706531	19x25	60	30,000	50	
		706533	19x25	80	30,000	50	
		706534	19x25	120	30,000	50	
		706535	22x20	36	26,000	50	
		706536	22x20	50	26,000	50	
		706537	22x20	60	26,000	50	
		706538	22x20	80	26,000	50	
		706539	22x20	120	26,000	50	
		706540	25x25	36	24,000	50	
706541	25x25	50	24,000	50			
706542	25x25	60	24,000	50			
706543	25x25	80	24,000	50			
706544	25x25	120	24,000	50			

	Shape	Type no.	Dimension	Grain	Max. RPM	PU	
		Spiral	706545	30x30	36	19,100	50
		706546	30x30	50	19,100	50	
		706547	30x30	60	19,100	50	
		706548	30x30	80	19,100	50	
		706550	30x30	120	19,100	50	
		706551	38x25	36	15,000	50	
		706552	38x25	50	15,000	50	
		706553	38x25	60	15,000	50	
		706555	38x25	80	15,000	50	
		706557	38x25	120	15,000	50	
		706558	45x30	36	12,700	50	
		706559	45x30	50	12,700	50	
		706560	45x30	60	12,700	50	
		706561	45x30	80	12,700	50	
		706562	45x30	120	12,700	50	
		706563	51x25	36	11,200	50	
		706564	51x25	50	11,200	50	
		706565	51x25	60	11,200	50	
		706566	51x25	80	11,200	50	
		706567	51x25	120	11,200	50	
		706568	60x30	36	9,500	50	
		706569	60x30	50	9,500	50	
		706570	60x30	60	9,500	50	
		706571	60x30	80	9,500	50	
		706573	60x30	120	9,500	50	
		706574	75x30	36	7,600	50	
		706575	75x30	50	7,600	50	
		706576	75x30	60	7,600	50	
706577	75x30	80	7,600	50			
706578	75x30	120	7,600	50			

**PREMIUM★★★ ACCESSORIES**

For spiral belts



This expandable rubber support has been specially designed for use with spiral belts. Expanding the flaps on the support enables the spiral belt to be fixed, ensuring it is safe and easy to mount.

These accessories are suitable for all spiral belts in our assortment.

	Shape		Type no.	Dimesnion	Max. RPM	PU
		SBH	710011	10x20-6x40	44,000	5
		710012	13x25-6x40	44,000	5	
		710013	15x30-6x40	36,000	5	
		710014	19x25-6x40	30,000	5	
		710015	22x20-6x40	26,000	5	
		710016	25x25-6x40	24,000	5	
		710017	30x30-6x40	19,100	5	
		710018	38x25-6x40	15,000	5	
		710022	45x30-6x40	12,700	5	
		710023	51x25-6x40	11,200	5	
		710025	60x30-6x40	9,500	5	
		710026	75x30-6x40	7,600	5	





## **4.8 ROUGH CLEANING WHEELS** STRAIGHT GRINDER



## ROUGH CLEANING WHEELS STRAIGHT GRINDER

Straight grinders are used when you need to work precisely in hard-to-reach locations. Would you like to remove rust, paint and varnish with a minimum of effort? Or do you need to prepare surfaces for welding, soldering or anodising?

The highly porous nylon fibres are evenly treated with aggressive abrasives and are able to meet any challenge. All of our rough cleaning discs resist loading or

smearing and offer long life with an even grinding pattern, but also low heat generation and quiet, stress-free working.

### Shapes

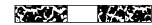

1GR Rough cleaning wheel

## Application recommendations

Performance Line	Specification	Pages	Steel	Stainless steel	Plastic steel
<b>STANDARD</b> ★★	C36-B	235	●	●	●

Items with grey lettering are only available on request.

Coated abrasives



**STANDARD★★ ROUGH CLEANING WHEELS**

For steel, stainless steel and PVC



With the TYROLIT rough cleaning wheel you can effortlessly remove rust, paint, lacquer and underbody sealant from your workpiece. The porous nylon fibres, treated with aggressive abrasives, meet any challenge. At the same time, they prevent clogging or loading.

This wheel offers the user quiet, non-strenuous grinding coupled with low generation of heat. When using the longer clamping spike, two 1GR can be clamped providing a greater contact area and faster progress.

	Shape		Type no.	Dimension	Specification	PU
		1GR	898048	75x13x8	C36-B	5
		898044	100x13x13	C36-B	5	
		898051	150x13x13	C36-B	5	
		943167	180x13x13	C36-B	5	
		943168	200x13x13	C36-B	5	

**ACCESSORIES**

For rough cleaning wheel



These accessories enable the 1GR rough cleaning wheel to be clamped onto straight grinders. Easy handling and the highest possible levels of safety are guaranteed for the operator. Please observe the maximum permissible speed of your tool.

		Type no.	Dimension	Specification	PU
	100SS	905335	S6/H8/L67	SS596	1
		905336	S6/H13/L52	SS597	1
		905337	S8/H13/L67	SS598	1





HYROLIT



## 4.9 SPINDLE-MOUNTED FLEECE FLAP WHEELS AND MOUNTED FLAP WHEELS STRAIGHT GRINDER

Coated  
abrasives







## SPINDLE-MOUNTED FLEECE FLAP WHEELS AND MOUNTED FLAP WHEELS FOR STRAIGHT GRINDERS

Straight grinders are used when you need to work precisely in hard-to-reach locations. Especially when used in conjunction with TYROLIT spindle-mounted fleece flap wheels and mounted flap wheels, they are a flexible tool for producing optimum workpiece contours.

The fan-shaped, abrasive grain flaps of the mounted flap wheels allow precise work on all surfaces. They can be used not only on electrical but also on pneumatic straight grinders. The TYROLIT assortment also includes a large number of spin-

dle-mounted fleece flap wheels in different shapes and designs. They are highly adaptable and ensure that no changes occur to the surface integrity. Spindle-mounted fleece flap wheels are available with or without embedded abrasive.

## Application recommendations

Performance Level	Pages	 Steel	 Stainless steel	 NF metals
MOUNTED FLAP WHEELS <b>PREMIUM***</b>	242-246	•	•	•
MOUNTED FLAP WHEELS <b>BASIC*</b>	247-248	•	•	•
SPINDLE-MOUNTED FLEECE FLAP WHEELS <b>PREMIUM***</b>	240-241	•	•	•

Items with grey lettering are only available on request.

## Shapes



52 VL Spindle-mounted fleece flap wheels



52 LAVL Spindle-mounted fleece flap wheels



552 LA Mounted flap wheels

**PREMIUM\*\*\* FLEECE FLAP WHEELS SPINDLE MOUNTED**



For steel, stainless steel and nonferrous metals





TYROLIT spindle-mounted fleece flap wheels are highly adaptable and ensure that no changes occur to the surface integrity. The TYROLIT Premium\*\*\* assortment has now been extended by 29 types in order to be able to offer you different grains and new dimensions.

Different surface structures and roughnesses can be achieved through the

variety of grain gradings. TYROLIT spindle-mounted fleece flap wheels are also available with inlaid coated abrasive, so that higher stock removal can be achieved and a coarser surface integrity created.

Shape	Type no.	Dimension	Grain	Design	Max. RPM	Rec. speed	PU	
	 52 LA VL	570473	40x20 6x40		A COARSE	9,000	7,500	10
		908708	40x20 6x40		A MEDIUM	9,000	7,500	10
		908712	40x20 6x40		A FINE	9,000	7,500	10
		388126	40x20 6x40		A VERY FINE	9,000	7,500	10
		136087	50x30 6x40		A MEDIUM	8,000	6,000	10
		136090	50x30 6x40		A VERY FINE	8,000	6,000	10
		908854	50x50 6x40		A MEDIUM	8,000	6,000	10
		570485	60x30 6x40		A COARSE	7,000	5,000	10
		908784	60x30-6x40		A MEDIUM	7,000	5,000	10
		908794	60x30-6x40		A FINE	7,000	5,000	10
		908795	60x30-6x40		A VERY FINE	7,000	5,000	10
		34054620	60x50 6x40		A COARSE	7,000	5,000	10
		908710	60x50 6x40		A MEDIUM	7,000	5,000	10
		908715	60x50 6x40		A FINE	7,000	5,000	10
		34054651	60x50 6x40		A VERY FINE	7,000	5,000	10
		908862	80x50 6x40		A COARSE	6,000	4,000	10
		372339	80x50 6x40		C MEDIUM	6,000	4,000	10
		908711	80x50-6x40		A MEDIUM	6,000	4,000	10
		908717	80x50-6x40		A FINE	6,000	4,000	10
		908796	80x50-6x40		A VERY FINE	6,000	4,000	10
 52LA VL-C	34053446	40x20 6x40	60	A COARSE	9,000	7,500	10	
	908775	40x20 6x40	80	A MEDIUM	9,000	7,500	10	
	908779	40x20 6x40	150	A FINE	9,000	7,500	10	
	34053447	50x30 6x40	60	A COARSE	8,000	6,000	10	
	136161	50x30 6x40	80	A MEDIUM	8,000	6,000	10	
	457370	50x30 6x40	150	A FINE	8,000	6,000	10	
	136164	50x30 6x40	240	A VERY FINE	8,000	6,000	10	



Shape	Type no.	Dimension	Grain	Design	Max. RPM	Rec. speed	PU	
		52LA VL-C 148718	50x50 6x40	120	A MEDIUM	8,000	6,000	10
		148722	50x50 6x40	240	A VERY FINE	8,000	6,000	10
		263249	60x30 6x40	60	A COARSE	7,000	5,000	10
		910902	60x30-6x40	80	A MEDIUM	7,000	5,000	10
		908780	60x30 6x40	150	A FINE	7,000	5,000	10
		908821	60x30 6x40	240	A VERY FINE	7,000	5,000	10
		136168	60x40 6x40	80	A MEDIUM	7,000	5,000	10
		136173	60x40 6x40	240	A VERY FINE	7,000	5,000	10
		34054652	60x50 6x40	60	A COARSE	7,000	5,000	10
		34054655	60x50 6x40	80	A MEDIUM	7,000	5,000	10
		34054658	60x50 6x40	150	A FINE	7,000	5,000	10
		239448	80x30 6x40	240	A VERY FINE	6,000	4,000	10
		908871	80x50 6x40	60	A COARSE	6,000	4,000	10
		910864	80x50-6x40	80	A MEDIUM	6,000	4,000	10
		136193	80x50 6x40	120	A MEDIUM	6,000	4,000	10
		910853	80x50-6x40	150	A FINE	6,000	4,000	10
		908823	80x50-6x40	240	A VERY FINE	6,000	4,000	10
		908872	100x50 6x40	60	A COARSE	4,000	3,000	10
		910890	100x50 6x40	80	A MEDIUM	4,000	3,000	10
		908826	100x50 6x40	150	A FINE	4,000	3,000	10
908825	100x50-6x40	240	A VERY FINE	4,000	3,000	10		

# PREMIUM★★★ MOUNTED FLAP WHEELS

## FOR STEEL, STAINLESS STEEL AND NONFERROUS METALS

### + High flexibility

Greater precision is made possible as the flaps adjust flexibly to the contours of each workpiece.

### + Universal use

TYROLIT mounted flap wheels can be used on both pneumatic and electric machines for different materials.



### + Less work required

The grinding of small and difficult-to-reach areas, for example in container construction and apparatus engineering, is not a problem for TYROLIT mounted flap wheels.

These tools adapt optimally to every workpiece contour thanks to their flexibility. The radially arranged flaps of the mounted flap wheels can be



used on various materials and permit precise work for different applications, such as matting, pre-polishing and the cleaning of surfaces.



The highly flexible flaps also make light work of machining hard-to-reach areas.

### PREMIUM★★★ MOUNTED FLAP WHEELS

For steel, stainless steel and nonferrous metals





	Shape	Type no.	Dimension	Grain	Max. RPM	Rec. speed	PU
		52LA-C					
		909383	10x10-3x40	80	35,000	26,000	10
		909385	10x10-3x40	120	35,000	26,000	10
		661085	10x10 3x40	150	35,000	26,000	10
		49856	20x10 6x40	60	30,000	20,000	10
		816831	20x10-6x40	80	30,000	20,000	10
		816833	20x10-6x40	120	30,000	20,000	10
		619800	20x10 6x40	150	30,000	20,000	10
816843	20x10 6x40	180	30,000	20,000	10		

Shape	Type no.	Dimension	Grain	Max. RPM	Rec. speed	PU	
 	52LA-C	886805	25x15 6x40	60	26,000	18,000	10
		816846	25x15 6x40	80	26,000	18,000	10
		816847	25x15 6x40	120	26,000	18,000	10
		909388	30x5-6x40	60	26,000	16,000	10
		909390	30x5-6x40	80	26,000	16,000	10
		909393	30x5-6x40	120	26,000	16,000	10
		909396	30x10 3x40	60	26,000	16,000	10
		909397	30x10-3x40	80	26,000	16,000	10
		909398	30x10-3x40	120	26,000	16,000	10
		816854	30x10 3x40	150	26,000	16,000	10
		909400	30x10 3x40	240	26,000	16,000	10
		959241	30x10 6x40	40	26,000	16,000	10
		816855	30x10-6x40	60	26,000	16,000	10
		816871	30x10-6x40	80	26,000	16,000	10
		816872	30x10-6x40	120	26,000	16,000	10
		816873	30x10-6x40	150	26,000	16,000	10
		909405	30x10-6x40	180	26,000	16,000	10
		816874	30x10-6x40	240	26,000	16,000	10
		816875	30x10-6x40	320	26,000	16,000	10
		939107	30x15 6x40	40	26,000	16,000	10
		816880	30x15-6x40	60	26,000	16,000	10
		816893	30x15-6x40	80	26,000	16,000	10
		816905	30x15-6x40	120	26,000	16,000	10
		816906	30x15 6x40	150	26,000	16,000	10
		667198	30x15 6x40	180	26,000	16,000	10
		909404	30x15 6x40	240	26,000	16,000	10
		432975	30x15 6x40	320	26,000	16,000	10
		82070	40x10 6x40	40	20,000	13,000	10
		648425	40x10 6x40	60	20,000	13,000	10
		82078	40x10 6x40	80	20,000	13,000	10
		82079	40x10 6x40	120	20,000	13,000	10
		910558	40x15 6x40	40	20,000	13,000	10
	816907	40x15-6x40	60	20,000	13,000	10	
	816908	40x15-6x40	80	20,000	13,000	10	

**PREMIUM\*\*\* MOUNTED FLAP WHEELS**



For steel, stainless steel and nonferrous metals



Shape	Type no.	Dimension	Grain	Max. RPM	Rec. speed	PU	
 	52LA-C	816909	40x15-6x40	120	20,000	13,000	10
		816911	40x15-6x40	150	20,000	13,000	10
		678198	40x15 6x40	180	20,000	13,000	10
		816912	40x15 6x40	240	20,000	13,000	10
		816913	40x15 6x40	320	20,000	13,000	10
		816914	40x20-6x40	40	20,000	13,000	10
		816915	40x20-6x40	60	20,000	13,000	10
		816916	40x20-6x40	80	20,000	13,000	10
		816918	40x20-6x40	120	20,000	13,000	10
		816919	40x20-6x40	150	20,000	13,000	10
		897078	40x20 6x40	180	20,000	13,000	10
		816920	40x20 6x40	240	20,000	13,000	10
		816921	40x20 6x40	320	20,000	13,000	10
		82117	50x10 6x40	60	16,000	11,000	10
		909362	50x10 6x40	80	16,000	11,000	10
		82125	50x10 6x40	120	16,000	11,000	10
		34053444	50x10 6x40	240	16,000	11,000	10
		82127	50x15 6x40	40	16,000	11,000	10
		816922	50x15-6x40	60	16,000	11,000	10
		816923	50x15-6x40	80	16,000	11,000	10
		816924	50x15-6x40	120	16,000	11,000	10
		816925	50x15 6x40	150	16,000	11,000	10
		816926	50x15 6x40	240	16,000	11,000	10
		816927	50x15 6x40	320	16,000	11,000	10
		816928	50x20-6x40	40	16,000	11,000	10
		816931	50x20-6x40	60	16,000	11,000	10
		816933	50x20-6x40	80	16,000	11,000	10
		816934	50x20-6x40	120	16,000	11,000	10
		848563	50x20-6x40	180	16,000	11,000	10
		816939	50x20-6x40	320	16,000	11,000	10

Coated abrasives





Shape	Type no.	Dimension	Grain	Max. RPM	Rec. speed	PU	
 	52LA-C	910574	50x30-6x40	40	16,000	11,000	10
		816940	50x30-6x40	60	16,000	11,000	10
		816941	50x30-6x40	80	16,000	11,000	10
		816942	50x30-6x40	120	16,000	11,000	10
		816943	50x30 6x40	150	16,000	11,000	10
		433019	50x30 6x40	180	16,000	11,000	10
		433020	50x30 6x40	240	16,000	11,000	10
		910572	50x30 6x40	320	16,000	11,000	10
		910587	60x15 6x40	40	13,500	9,000	10
		816949	60x15-6x40	60	13,500	9,000	10
		816950	60x15-6x40	80	13,500	9,000	10
		816951	60x15 6x40	120	13,500	9,000	10
		816952	60x15 6x40	150	13,500	9,000	10
		910579	60x15 6x40	240	13,500	9,000	10
		910707	60x20 6x40	40	13,500	9,000	10
		816953	60x20-6x40	60	13,500	9,000	10
		816954	60x20-6x40	80	13,500	9,000	10
		816955	60x20-6x40	120	13,500	9,000	10
		816956	60x20-6x40	150	13,500	9,000	10
		433039	60x20 6x40	180	13,500	9,000	10
		816957	60x20 6x40	240	13,500	9,000	10
		816958	60x20-6x40	320	13,500	9,000	10
		817011	60x30-6x40	40	13,500	9,000	10
		816959	60x30-6x40	60	13,500	9,000	10
		816960	60x30-6x40	80	13,500	9,000	10
		816961	60x30-6x40	120	13,500	9,000	10
		816962	60x30-6x40	150	13,500	9,000	10
		909368	60x30 6x40	180	13,500	9,000	10
		816963	60x30 6x40	240	13,500	9,000	10
		816964	60x30 6x40	320	13,500	9,000	10
	817012	60x40-6x40	40	13,500	9,000	10	
	816965	60x40-6x40	60	13,500	9,000	10	
	816966	60x40-6x40	80	13,500	9,000	10	
	816967	60x40-6x40	120	13,500	9,000	10	
	816968	60x40 6x40	150	13,500	9,000	10	
	816969	60x40 6x40	240	13,500	9,000	10	

**PREMIUM\*\*\* MOUNTED FLAP WHEELS**

For steel, stainless steel and nonferrous metals



Shape	Type no.	Dimension	Grain	Max. RPM	Rec. speed	PU	
 	52LA-C	816971	60x50 6x40	40	13,500	9,000	10
		816972	60x50-6x40	60	13,500	9,000	10
		816973	60x50 6x40	80	13,500	9,000	10
		816974	60x50 6x40	120	13,500	9,000	10
		910718	80x15 6x40	60	10,000	6,000	10
		82256	80x15 6x40	80	10,000	6,000	10
		82257	80x15 6x40	120	10,000	6,000	10
		816976	80x20 6x40	60	10,000	6,000	10
		816977	80x20 6x40	80	10,000	6,000	10
		816978	80x20 6x40	120	10,000	6,000	10
		910722	80x30-6x40	40	10,000	6,000	10
		816981	80x30-6x40	60	10,000	6,000	10
		816982	80x30-6x40	80	10,000	6,000	10
		816983	80x30-6x40	120	10,000	6,000	10
		816984	80x30-6x40	150	10,000	6,000	10
		433068	80x30 6x40	180	10,000	6,000	10
		915573	80x30 6x40	240	10,000	6,000	10
		910720	80x30 6x40	320	10,000	6,000	10
		816985	80x40-6x40	60	10,000	6,000	10
		816986	80x40-6x40	80	10,000	6,000	10
		816987	80x40 6x40	120	10,000	6,000	10
		816989	80x40 6x40	240	10,000	6,000	10
		87910	80x50 6x40	40	10,000	6,000	10
		816990	80x50-6x40	60	10,000	6,000	10
		816991	80x50-6x40	80	10,000	6,000	10
		816992	80x50 6x40	120	10,000	6,000	10
		816993	80x50 6x40	150	10,000	6,000	10
		817001	80x50 6x40	240	10,000	6,000	10
		817003	80x50 6x40	320	10,000	6,000	10



**BASIC★ MOUNTED FLAP WHEELS**

For steel, stainless steel and nonferrous metals



The BASIC★ mounted flap wheels adapt well to every workpiece contour thanks to their flexibility. The radially arranged flaps of the mounted flap wheels can be used on various materials and permit precise work for different applications, such as matting, pre-polishing and the cleaning of surfaces.



The highly flexible flaps also make light work of machining hard-to-reach areas.

Shape	Type no.	Dimension	Grain	Max. RPM	Rec. speed	PU	
	 52LA-C	34054618	30x10 6x40	40	26,000	16,000	10
		34054619	30x10 6x40	60	26,000	16,000	10
		34054737	30x10 6x40	80	26,000	16,000	10
		34054660	30x10 6x40	120	26,000	16,000	10
		34054738	30x10 6x40	180	26,000	16,000	10
		34054739	40x15 6x40	40	20,000	13,000	10
		34054751	40x15 6x40	60	20,000	13,000	10
		34054753	40x15 6x40	80	20,000	13,000	10
		34054754	40x15 6x40	120	20,000	13,000	10
		34054758	40x15 6x40	180	20,000	13,000	10
		34054759	40x20 6x40	40	20,000	13,000	10
		34054760	40x20 6x40	60	20,000	13,000	10
		34054783	40x20 6x40	80	20,000	13,000	10
		34054784	40x20 6x40	120	20,000	13,000	10
		34054785	40x20 6x40	180	20,000	13,000	10
		34054786	50x15 6x40	40	16,000	11,000	10
		34054787	50x15 6x40	60	16,000	11,000	10
		34054788	50x15 6x40	80	16,000	11,000	10
		34054789	50x15 6x40	120	16,000	11,000	10
		34054801	50x20 6x40	40	16,000	11,000	10
		34054805	50x20 6x40	60	16,000	11,000	10
		34054809	50x20 6x40	80	16,000	11,000	10
34054812	50x20 6x40	120	16,000	11,000	10		
34054813	50x20 6x40	180	16,000	11,000	10		
34054814	50x30 6x40	40	16,000	11,000	10		
34054817	50x30 6x40	60	16,000	11,000	10		
34054820	50x30 6x40	80	16,000	11,000	10		
34054831	50x30 6x40	120	16,000	11,000	10		
34054832	50x30 6x40	180	16,000	11,000	10		

**BASIC★ MOUNTED FLAP WHEELS**

For steel, stainless steel and nonferrous metals



Shape	Type no.	Dimension	Grain	Max. RPM	Rec. speed	PU	
 	52LA-C	34054834	60x20 6x40	40	13,500	9,000	10
	34054836	60x20 6x40	60	13,500	9,000	10	
	34054837	60x20 6x40	80	13,500	9,000	10	
	34054839	60x20 6x40	120	13,500	9,000	10	
	34054840	60x20 6x40	180	13,500	9,000	10	
	34054852	60x30 6x40	40	13,500	9,000	10	
	34054854	60x30 6x40	60	13,500	9,000	10	
	34054855	60x30 6x40	80	13,500	9,000	10	
	34054856	60x30 6x40	120	13,500	9,000	10	
	34054857	60x30 6x40	180	13,500	9,000	10	
	34054858	80x30 6x40	40	10,000	6,000	10	
	34054860	80x30 6x40	60	10,000	6,000	10	
	34054861	80x30 6x40	80	10,000	6,000	10	
	34054862	80x30 6x40	120	10,000	6,000	10	
	34054863	80x30 6x40	180	10,000	6,000	10	





**4.10 BELTS**  
BELT GRINDER





## BELTS

# FOR MINI BELT GRINDERS, PORTABLE BELT GRINDERS AND CONTACT GRINDERS

In this chapter you will find belts for metal and wood processing in different sizes for mini belt grinders, portable belt grinders and large, stationary contact grinders.

Depending on the application, we have the right belt for an optimum result, whether you need long life, maximum stock removal or a perfect surface finish. With their high stock removal rate, belts with embedded ceramic grain offer a quick and easy

way of grinding metal. We also offer products with a range of flexible underlays and additional coatings. These allow you to work on harder materials, such as stainless steel, alloys, structural steel and non-ferrous metals. They can also be used

with woods, paints and lacquers. TYROLIT coated abrasives have been developed with particular applications in mind and thus achieve the best possible results in day-to-day use.

## Shapes



**Belt 1**  
For mini belt grinders



**Belt 2**  
For portable belt grinders



**Belt 3**  
For contact grinders

## Belt joints



TYROLIT belts are available with two different belt joints.



**JTS** (Joint Tape Straight) mainly for metal processing

**JOT** (Joint Overlap Top) mainly for wood processing



## Application recommendations

Performance Level	Specification	Pages			
			Steel	Stainless steel	NF metals
<b>PREMIUM***</b>	ZA-P41 PC X	252-253, 258-260	●		●
	ZA-P43 PE Y	260	●		●
	ZA-P47 PA Y	252-253	●	●	
	CA-P93 PE Y	257	●	●	

Performance	Specification	Pages			
			Steel	Plastic	Wood
<b>BASIC*</b>	A-B06 PC X	255-256	●	●	●

Performance	Specification	Pages			
			All in One		
SCM BELTS <b>PREMIUM***</b>		254.261			●

Items with grey lettering are only available on request.

Coated abrasives



**PREMIUM\*\*\* ZA-P48 PE Y / ZA-P41 PC X MINI BELTS**

For steel, stainless steel and aluminium





The Premium\*\*\* belts have been specially designed for the mini belt grinder and prevent grain break outs on the tool due to their special curvature. A good stock removal rate and long lifetime allow consistent results to be delivered in shorter working hours. Our belts are easy to handle and mount.

TYROLIT mini belts can be used on all steel, stainless steel and nonferrous metals.

Shape	Type no.	Dimension	Grain	Connection	PU
  Belt 1	706281	6x533	40	JTS	20
	706282	6x533	60	JTS	20
	706283	6x533	80	JTS	20
	706284	6x533	120	JTS	20
	706285	6x610	40	JTS	20
	706286	6x610	60	JTS	20
	706290	6x610	80	JTS	20
	706291	6x610	120	JTS	20
	706292	9x533	40	JTS	20
	706293	9x533	60	JTS	20
	706295	9x533	80	JTS	20
	706299	9x533	120	JTS	20
	706300	10x330	40	JTS	20
	706301	10x330	60	JTS	20
	706302	10x330	80	JTS	20
	706303	10x330	120	JTS	20
706305	12x330	40	JTS	20	
706306	12x330	60	JTS	20	
706307	12x330	80	JTS	20	
706308	12x330	120	JTS	20	
706309	12x457	40	JTS	20	
706310	12x457	60	JTS	20	
706311	12x457	80	JTS	20	
706312	12x457	120	JTS	20	
706313	12x533	40	JTS	20	
706314	12x533	60	JTS	20	
706315	12x533	80	JTS	20	
706316	12x533	120	JTS	20	



Shape	Type no.	Dimension	Grain	Connection	PU	
 	Belt 1	706317	13x455	40	JTS	20
	706318	13x455	60	JTS	20	
	706320	13x455	80	JTS	20	
	706323	13x455	120	JTS	20	
	706324	13x610	40	JTS	20	
	706325	13x610	60	JTS	20	
	706327	13x610	80	JTS	20	
	706328	13x610	120	JTS	20	
	706329	15x475	40	JTS	20	
	706330	15x475	60	JTS	20	
	706331	15x475	80	JTS	20	
	706333	15x475	120	JTS	20	
	706336*	20x480	40	JTS	20	
	706337*	20x480	60	JTS	20	
	706338*	20x480	80	JTS	20	
	706340*	20x480	120	JTS	20	
	706341*	20x520	40	JTS	20	
	706342*	20x520	60	JTS	20	
	706343*	20x520	80	JTS	20	
	706344*	20x520	120	JTS	20	
	706345*	29x533	40	JTS	20	
	706346*	29x533	60	JTS	20	
	706347*	29x533	80	JTS	20	
	706348*	29x533	120	JTS	20	

\* ZA-P41 PC X

**PREMIUM★★★ SCM BELTS**

Universal use

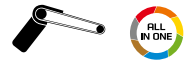

With belts from the TYROLIT SCM range, TYROLIT is taking another step towards economic efficiency. The machining time of the workpiece can now be greatly reduced. A saving of one to three work steps is thus the key benefit.

Thanks to the quick and high stock removal rate, applications such as the

reduction of surface roughness, removal of discolouration, smoothing of surfaces and the cleaning and removal of weld seams can be realised.

In addition, the TYROLIT SCM range boasts the best results in terms of lifetime.

	Shape	Type no.	Dimension	Design	Connection	Colour	PU	
		Belt 1	34047759	6x457	COARSE	JTS	BROWN	20
		34047771	6x457	MEDIUM	JTS	RED	20	
		34047772	6x457	VERY FINE	JTS	BLUE	20	
		34047773	6x610	COARSE	JTS	BROWN	20	
		34047774	6x610	MEDIUM	JTS	RED	20	
		34047775	6x610	VERY FINE	JTS	BLUE	20	
		34047776	12x520	COARSE	JTS	BROWN	20	
		34047777	12x520	MEDIUM	JTS	RED	20	
		34047779	12x520	VERY FINE	JTS	BLUE	20	
		34047780	13x457	COARSE	JTS	BROWN	20	
		34047784	13x457	MEDIUM	JTS	RED	20	
		34047785	13x457	VERY FINE	JTS	BLUE	20	
		34047789	13x610	COARSE	JTS	BROWN	20	
		34047790	13x610	MEDIUM	JTS	RED	20	
		34047792	13x610	VERY FINE	JTS	BLUE	20	
		34047794	19x457	COARSE	JTS	BROWN	10	
		34047796	19x457	MEDIUM	JTS	RED	10	
		34047797	19x457	VERY FINE	JTS	BLUE	10	
		34047798	19x520	COARSE	JTS	BROWN	10	
		34047799	19x520	MEDIUM	JTS	RED	10	
34047800	19x520	VERY FINE	JTS	BLUE	10			
34047814	30x533	COARSE	JTS	BROWN	10			
34047815	30x533	MEDIUM	JTS	RED	10			
34049667	30x533	VERY FINE	JTS	BLUE	10			



## BASIC★ A-B06 PC X BELTS

Universal use



The BASIC★ belts for the portable belt grinder can be used universally, but are most commonly used on wood. They are suited to this use as they comprise aluminium oxide and polycotton backing. A special grain coating prevents loading of the belts when grinding soft materials, such as wood and paints.

This delivers a good grinding power and long lifetime. Simple handling and mounting save extra working time.

	Shape	Type no.	Dimension	Grain	Connection	PU
		Belt 2				
		706349	40x305	40	JOT	20
		706350	40x305	60	JOT	20
		706351	40x305	80	JOT	20
		706352	40x305	120	JOT	20
		706353	60x400	40	JOT	10
		706354	60x400	60	JOT	10
		706356	60x400	80	JOT	10
		706361	60x400	100	JOT	10
		706362	60x400	120	JOT	10
		706363	65x410	40	JOT	10
		706364	65x410	60	JOT	10
		706365	65x410	80	JOT	10
		706366	65x410	100	JOT	10
		706367	65x410	120	JOT	10
		706368	75x457	40	JOT	10
		706369	75x457	60	JOT	10
		706370	75x457	80	JOT	10
		706371	75x457	100	JOT	10
		706372	75x457	120	JOT	10
		706375	75x480	40	JOT	10
		706376	75x480	60	JOT	10
		706377	75x480	80	JOT	10
		706380	75x480	100	JOT	10
		706381	75x480	120	JOT	10
		706383	75x533	40	JOT	10
		706384	75x533	60	JOT	10
		706385	75x533	80	JOT	10
706386	75x533	100	JOT	10		
706387	75x533	120	JOT	10		

**BASIC★ A-B06 PC X BELTS**

Universal use



	Shape	Type no.	Dimension	Grain	Connection	PU
		706388	100x552	40	JOT	10
		706393	100x552	60	JOT	10
		706394	100x552	80	JOT	10
		706395	100x552	100	JOT	10
		706397	100x552	120	JOT	10
		706398	100x560	40	JOT	10
		706399	100x560	60	JOT	10
		706401	100x560	80	JOT	10
		706402	100x560	100	JOT	10
		706403	100x560	120	JOT	10
		706404	100x610	40	JOT	10
		706405	100x610	60	JOT	10
		706406	100x610	80	JOT	10
		706407	100x610	100	JOT	10
		706408	100x610	120	JOT	10
		706409	100x620	40	JOT	10
		706410	100x620	60	JOT	10
		706411	100x620	80	JOT	10
		706413	100x620	100	JOT	10
		706414	100x620	120	JOT	10
706415	110x620	40	JOT	10		
706416	110x620	60	JOT	10		
706417	110x620	80	JOT	10		
706418	110x620	100	JOT	10		
706419	110x620	120	JOT	10		



# PREMIUM\*\*\* CA-P93 PE Y BELTS FOR STEEL AND STAINLESS STEEL

**+ Reduced load**

The high abrasiveness of the belts means that the operator can apply less pressure.

**+ Consistent surface result**

Even grinding surface pattern thanks to uniform easy-cutting ceramic grain.



**+ Maximum abrasiveness**

The ceramic PREMIUM\*\*\* belts achieve the highest values in terms of abrasiveness and therefore offer the greatest possible stock removal rate.

Belts with self-sharpening ceramic grain offer a high stock removal rate on steel and stainless steel. Thanks

to this self-sharpening effect, an even surface quality is achieved over the entire lifetime of the abrasive belts.

Moreover, the composition of the abrasive belt reduces effort for the operator as less pressure is required.

## PREMIUM\*\*\* CA-P93 PE Y BELTS

For steel and stainless steel



	Shape	Type no.	Dimension	Grain	Connection	PU
		34168478	75x2000	24	JTS	10
		34168479	75x2000	36	JTS	10
		34168480	75x2000	40	JTS	10
		34168481	75x2000	60	JTS	10
		34168482	75x2000	80	JTS	10
		34168483	75x2000	120	JTS	10

**PREMIUM★★★ ZA-P47 PC Y BELTS**

For steel and stainless steel



Due to the hard zirconium used in these PREMIUM★★★ belts they are ideal for very high pressure and deliver above-average stock removal rates. Active coolants reduce the generation of heat while grinding. This high-performance product equipped with durable polyester backing has been developed for demanding steel and stainless steel applications.

These products are mainly used for dry applications.

	Shape	Type no.	Dimension	Grain	Connection	PU
		706437	50x2000	36	JTS	10
		706438	50x2000	60	JTS	10
		706441	50x2000	80	JTS	10
		706442	50x2000	120	JTS	10
		706473	75x2000	36	JTS	10
		706474	75x2000	60	JTS	10
		706475	75x2000	80	JTS	10
		706477	75x2000	120	JTS	10

**PREMIUM★★★ ZA-P41 PC X BELTS**



For steel and nonferrous metals



This high-performance product equipped with durable polyester has been developed for demanding steel and nonferrous metal applications. Combined with hard zirconium, these belts are ideal for very high pressure and deliver above-average stock removal rates. Active coolants reduce the generation of heat while grinding.

Another special feature is that the product can also be used wet with oil, emulsion or water and still delivers optimal results.

	Shape	Type no.	Dimension	Grain	Connection	PU
		706420	50x1000	40	JTS	10
		706421	50x1000	60	JTS	10
		706422	50x1000	80	JTS	10
		706424	50x1000	120	JTS	10
		706426	50x2000	40	JTS	10
		706428	50x2000	60	JTS	10
		706429	50x2000	80	JTS	10
		706430	50x2000	120	JTS	10
		706443	50x2500	40	JTS	10
		706444	50x2500	60	JTS	10
		706446	50x2500	80	JTS	10
		706447	50x2500	120	JTS	10

	Shape	Type no.	Dimension	Grain	Connection	PU
		Belt 3				
		706449	50x3000	40	JTS	10
		706450	50x3000	60	JTS	10
		706451	50x3000	80	JTS	10
		706452	50x3000	120	JTS	10
		706453	50x3500	40	JTS	10
		706454	50x3500	60	JTS	10
		706455	50x3500	80	JTS	10
		706456	50x3500	120	JTS	10
		706457	50x4000	40	JTS	10
		706459	50x4000	60	JTS	10
		706460	50x4000	80	JTS	10
		706461	50x4000	120	JTS	10
		706463	75x2000	40	JTS	10
		706464	75x2000	60	JTS	10
		706465	75x2000	80	JTS	10
		706466	75x2000	120	JTS	10
		706478	75x2250	40	JTS	10
		706480	75x2250	60	JTS	10
		706481	75x2250	80	JTS	10
		706482	75x2250	120	JTS	10
		706483	75x2500	40	JTS	10
		706484	75x2500	60	JTS	10
		706489	75x2500	80	JTS	10
		706492	75x2500	120	JTS	10
		706493	100x915	40	JTS	10
		706494	100x915	60	JTS	10
		706497	100x915	80	JTS	10
		706499	100x915	120	JTS	10
		706500	100x1000	40	JTS	10
		706501	100x1000	60	JTS	10
		706502	100x1000	80	JTS	10
		706503	100x1000	120	JTS	10

**PREMIUM★★★ ZA-P41 PC X BELTS**

For steel and nonferrous metals



This high-performance product equipped with durable polyester has been developed for demanding steel and nonferrous metal applications. Combined with hard zirconium, these belts are ideal for very high pressure and deliver above-average stock removal rates. Active coolants reduce the generation of heat while grinding.

Another special feature is that the product can also be used wet with oil, emulsion or water and still delivers optimal results.

	Shape	Type no.	Dimension	Grain	Connection	PU
		706504	150x2000	40	JTS	10
		706506	150x2000	60	JTS	10
		706507	150x2000	80	JTS	10
		706508	150x2000	120	JTS	10
		706509	150x2500	40	JTS	10
		706511	150x2500	60	JTS	10
		706512	150x2500	80	JTS	10
		706513	150x2500	120	JTS	10

**PREMIUM★★★ ZA-P43 PE Y BELTS**

For steel and nonferrous metals



This high-performance product equipped with durable polyester has been developed for demanding steel and nonferrous metal applications. Combined with hard zirconium, these belts are ideal for very high pressure and deliver above-average stock removal rates. Active coolants reduce the generation of heat while grinding.

Another special feature is that the product can also be used wet with oil, emulsion or water and still delivers optimal results.

	Shape	Type no.	Dimension	Grain	Connection	PU
		706432	50x2000	36	JTS	10
		706433	50x2000	40	JTS	10
		706434	50x2000	60	JTS	10
		706435	50x2000	80	JTS	10
		706436	50x2000	120	JTS	10
		706467	75x2000	36	JTS	10
		706469	75x2000	40	JTS	10
		706470	75x2000	60	JTS	10
		706471	75x2000	80	JTS	10
		706472	75x2000	120	JTS	10



**PREMIUM★★★ SCM BELTS**



Universal use



With belts from the TYROLIT SCM range, TYROLIT is taking another step towards economic efficiency. The machining time of the workpiece can now be greatly reduced. A saving of one to three work steps is thus the key benefit.

Thanks to the quick and high stock removal rate, applications such as the

reduction of surface roughness, removal of discolouration, smoothing of surfaces and the cleaning and removal of weld seams can be realised. In addition, the TYROLIT SCM range boasts the best results in terms of lifetime.

	Shape	Type no.	Dimension	Design	Connection	Colour	PU
		34049705	50x2000	COARSE	JTS	BROWN	6
		34049706	50x2000	MEDIUM	JTS	RED	6
		34049709	50x2000	VERY FINE	JTS	BLUE	6
		34049731	75x2000	COARSE	JTS	BROWN	4
		34049732	75x2000	MEDIUM	JTS	RED	4
		34049734	75x2000	VERY FINE	JTS	BLUE	4
		34049736	150x2000	COARSE	JTS	BROWN	2
		34049737	150x2000	MEDIUM	JTS	RED	2
		34049738	150x2000	VERY FINE	JTS	BLUE	2







## **4.11 ROLLS**

HAND SANDING AND SUPERFINISHING



## ROLLS FOR HAND SANDING AND SUPERFINISHING

Any kind of surface finishing requires thorough preparation. This can be done by hand or using an orbital sander.

Wood, paint or lacquer are usually abraded by hand. Deburring work can also be accomplished by hand. However, for perfect intermediate sanding, we recommend using an orbital sander. This also allows smooth finishing of coatings and smoothing of composite materials.

For jobs such as these we offer abrasive rolls in a wide range of designs, such as cloth, paper and fleece rolls. They allow easy and flexible working on virtually any material.

### Shapes



Roll



# Application recommendations



Performance Level	Specification	Pages	All in One
CLOTH ROLLS <b>BASIC★</b>	A-B01 C JX	267, 268	●
	A-B01 C JJ	269, 270	●



Performance Level	Specification	Pages	Steel	NF metals	Paint / lacquer	Wood	Wet
PAPER ROLLS <b>PREMIUM★★★</b>	A-P07 P C	266	●	●	●	●	●



Performance Level	Specification	Pages	Plastic	Wood
PAPER ROLLS <b>BASIC★</b>	A-B35 P C	266	●	●
	A-B35 P A	266	●	●



Performance Level	Specification	Pages	All in One
FLEECE ROLLS <b>PREMIUM★★★</b>		271	●

Items with grey lettering are only available on request.

Coated abrasives



**PREMIUM\*\*\* A-P07 P C PAPER ROLLS**

For steel, nonferrous metals, wood, paints and lacquers

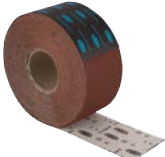

The special feature of the PREMIUM\*\*\* paper rolls is a latex-finished backing, which makes them ideal for wet and dry applications. This is the perfect product for preparing and machining metal, wood, paint and lacquer.

The closed coating of the PREMIUM\*\*\* paper roll delivers an excellent surface finish.

	Shape	Type no.	Dimension	Specification	PU	
		Roll	705945	100x50M	60	1
		705946	100x50M	80	1	
		705947	100x50M	100	1	
		705948	100x50M	120	1	
		705959	100x50M	150	1	
		705960	100x50M	180	1	
		705962	100x50M	240	1	
		705965	115x50M	60	1	
		705966	115x50M	80	1	
		705967	115x50M	100	1	
		705968	115x50M	120	1	
		705969	115x50M	150	1	
		705970	115x50M	180	1	
		705972	115x50M	240	1	



**BASIC\* A-B35 P C | A-B35 P A PAPER ROLLS**

For plastic and wood



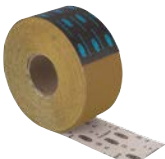

With an open grain distribution on a lightweight paper backing, TYROLIT paper rolls are ideal for dry grinding. This enables use on different types of wood, paints and lacquers.

The semi-open coating of the BASIC\* paper roll prevents loading of the product and delivers an excellent surface finish.

	Shape	Type no.	Dimension	Specification	PU	
		Roll	705975	100x50M	60	1
		705976	100x50M	80	1	
		705977	100x50M	100	1	
		705978	100x50M	120	1	
		705979	100x50M	150	1	
		705980	100x50M	180	1	
		705981	100x50M	240	1	
		705982	115x50M	60	1	
		705983	115x50M	80	1	

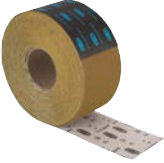
Coated abrasives

	Shape	Type no.	Dimension	Specification	PU	
		Roll	705984	115x50M	100	1
		705985	115x50M	120	1	
		705986	115x50M	150	1	
		705987	115x50M	180	1	
		705988	115x50M	240	1	



**BASIC★ A-B01 C JX CLOTH ROLLS**

Universal use



With flexible cloth rolls from TYROLIT you can machine almost any material. When finishing surfaces, preparation either by hand or using an orbital sander is required. When machining wood, paint and lacquer, TYROLIT recommends BASIC\* cloth rolls for hand-guided grinding.

For finishing coatings, smoothing and cleaning composites, and for clean intermediate grinding, we recommend cloth rolls on an orbital sander.

	Shape	Type no.	Dimension	Specification	PU	
		Roll	705824	25x50M	40	1
		705825	25x50M	60	1	
		705826	25x50M	80	1	
		705828	25x50M	100	1	
		705830	25x50M	120	1	
		705831	25x50M	150	1	
		705832	25x50M	180	1	
		705833	25x50M	220	1	
		705834	25x50M	240	1	
		705836	25x50M	320	1	
		705837	25x50M	400	1	
		705839	40x25M	40	1	
		705840	40x25M	60	1	
		705841	40x25M	80	1	
		705842	40x25M	100	1	
		705843	40x25M	120	1	
		705844	40x25M	150	1	
		705845	40x25M	180	1	
		705846	40x25M	220	1	
		705850	40x25M	240	1	
		705851	40x25M	320	1	
		705852	40x25M	400	1	
		705853	40x25M	600	1	



Coated abrasives

**BASIC★ A-B01 C JX CLOTH ROLLS**  
 Universal use

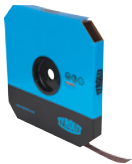

With flexible cloth rolls from TYROLIT you can machine almost any material. When finishing surfaces, preparation either by hand or using an orbital sander is required. When machining wood, paint and lacquer, TYROLIT recommends BASIC★ cloth rolls for hand-guided grinding.

For finishing coatings, smoothing and cleaning composites, and for clean intermediate grinding, we recommend cloth rolls on an orbital sander.

	Shape	Type no.	Dimension	Specification	PU	
		Roll	705854	40x50M	40	1
		705855	40x50M	60	1	
		705856	40x50M	80	1	
		705857	40x50M	100	1	
		705858	40x50M	120	1	
		705859	40x50M	150	1	
		705860	40x50M	180	1	
		705861	40x50M	220	1	
		705862	40x50M	240	1	
		705863	40x50M	320	1	
		705864	40x50M	400	1	
		705873	50x25M	40	1	
		705874	50x25M	60	1	
		705875	50x25M	80	1	
		705876	50x25M	100	1	
		705877	50x25M	120	1	
		705878	50x25M	150	1	
		705879	50x25M	180	1	
		705880	50x25M	220	1	
		705881	50x25M	240	1	
		705882	50x25M	320	1	
		705883	50x25M	400	1	
		705884	50x25M	600	1	
		705885	50x50M	40	1	
		705886	50x50M	60	1	
		705887	50x50M	80	1	
		705888	50x50M	100	1	
		705889	50x50M	120	1	
		705891	50x50M	150	1	
		705892	50x50M	180	1	
		705894	50x50M	220	1	
		705895	50x50M	240	1	
705896	50x50M	320	1			
705898	50x50M	400	1			

Coated abrasives







**BASIC★ A-B01 C JJ CLOTH ROLL**

Universal use



With highly flexible cloth rolls from TYROLIT you can machine almost any material. When finishing surfaces, preparation either by hand or using an orbital sander is required. When machining wood, paint and lacquer, TYROLIT recommends BASIC\* cloth rolls for hand-guided grinding.

For finishing coatings, smoothing and cleaning composites, and for clean intermediate grinding, we recommend cloth rolls on an orbital sander.

	Shape		Type no.	Dimension	Specification	PU
		Roll	20781	40x50M	60	1
			20793	40x50M	80	1
			20794	40x50M	100	1
			20796	40x50M	120	1
			20797	40x50M	150	1
			20798	40x50M	180	1
			20799	40x50M	220	1
			20801	40x50M	240	1
			20803	40x50M	320	1
			20805	40x50M	400	1
			20806	50x50M	60	1
			20807	50x50M	80	1
			20811	50x50M	100	1
			20813	50x50M	120	1
			20816	50x50M	150	1
			20817	50x50M	180	1
			20819	50x50M	220	1
			20821	50x50M	240	1
			20822	50x50M	320	1
			20824	50x50M	400	1
		Roll	34061912	100x50M	60	1
			34061913	100x50M	80	1
			34061919	100x50M	100	1
			34061934	100x50M	120	1
			34061938	100x50M	150	1
			34061939	100x50M	180	1
			34061951	100x50M	240	1
			34061953	100x50M	320	1
			34061954	100x50M	400	1
			34061960	115x50M	60	1
			34062015	115x50M	80	1
			34062021	115x50M	100	1
			34062022	115x50M	120	1
			34062023	115x50M	150	1

Coated abrasives



**BASIC★ A-B01 C JJ CLOTH ROLL**

Universal use



With highly flexible cloth rolls from TYROLIT you can machine almost any material. When finishing surfaces, preparation either by hand or using an orbital sander is required. When machining wood, paint and lacquer, TYROLIT recommends BASIC\* cloth rolls for hand-guided grinding.

For finishing coatings, smoothing and cleaning composites, and for clean intermediate grinding, we recommend cloth rolls on an orbital sander.

	Shape	Type no.	Dimension	Specification	PU	
		Roll	34062024	115x50M	180	1
			34062025	115x50M	240	1
			34062026	115x50M	320	1
			34062027	115x50M	400	1

# PREMIUM★★★ FLEECE ROLLS

## UNIVERSAL USE

**+ Long lifetime**

Thanks to 100% impregnation, the abrasive grain is not only located on the surface, but also inside the fleece.

**+ Flexible use**

The abrasive fabric adapts perfectly to any workpiece surface.



**+ Universal use**

The assortment offers a wide selection of possible uses on all common materials

TYROLIT fleece rolls are used for cleaning and processing surfaces using orbital sanders or for hand-guided grinding. A wide range of speci-

cations offer the user a variety of surface finish options. The assortment extends from coarse specifications for cleaning weld

seams through to ultra-fine and polishing fleece.

### PREMIUM★★★ FLEECE ROLLS

Universal use



	Shape	Type no.	Dimension	Conforms to	Design	Colour	PU
	Roll	120653	100 x 10m	P150	A COARSE	BROWN	1
		120667	100 x 10m	P220-240	A MEDIUM	RED-BROWN	1
		120671	100 x 10m	P320	A FINE	RED-BROWN	1
		120674	100 x 10m	P400-500	A VERY FINE	RED-BROWN	1
		120676	100 x 10m	P800	C SUPERFINE	GREY	1
		120682	100 x 10m	P400-500	A GP - GREEN	GREEN	1
		120688	115 x 10m	P150	A COARSE	BROWN	1
		120689	115 x 10m	P220-240	A MEDIUM	RED-BROWN	1
		120693	115 x 10m	P320	A FINE	RED-BROWN	1
		120694	115 x 10m	P400-500	A VERY FINE	RED-BROWN	1
		120700	115 x 10m	P800	C SUPERFINE	GREY	1
		120716	115 x 10m	P400-500	A GP - GREEN	GREEN	1







**4.12 SHEETS**  
HAND SANDING AND SUPERFINISHING





## SHEETS FOR HAND SANDING AND SUPERFINISHING

Any kind of surface finishing requires thorough preparation. This can be done by hand or using an orbital sander.

Wood, paint or lacquer are usually abraded by hand. Deburring work can also be accomplished by hand. However, for perfect intermediate sanding, we recommend using an orbital sander. This also allows smooth finishing of coatings and smoothing of composite materials.

For jobs like these we offer abrasive sheets in a wide range of designs, such as cloth, paper and fleece rolls. They allow easy and flexible working on virtually any material.

### Shapes



Sheet

# Application recommendations



Performance Level	Specification	Pages	All in One
CLOTH SHEETS <b>BASIC★</b>	A-B01 C JX	277, 278	●
	A-B01 C JJ	278	●



Performance Level	Specification	Pages	Steel	NF metals	Paint / lacquer	Wood	Stone	Wet
PAPER SHEETS <b>PREMIUM★★★</b>	A-P07 P C	276	●	●	●	●		●
	C-P68 P A	276	●	●	●	●	●	●
	C-P68 P C	276	●	●	●	●	●	●



Performance Level	Specification	Pages	Plastic	Wood
PAPER SHEETS <b>BASIC★</b>	A-B35 P C	277	●	●
	A-B35 P A	277	●	●



Performance Level	Pages	All in One
FLEECE ROLLS <b>PREMIUM★★★</b>	279	●

Items with grey lettering are only available on request.

Coated abrasives

### PREMIUM\*\*\* A-P07 P C PAPER SHEETS

For steel, nonferrous metals, wood, paints and lacquers



The special feature of the PREMIUM\*\*\* paper sheets is a latex-finished backing, which makes them ideal for wet and dry finishing. This is the perfect product for preparing and machining metal, wood, paint and lacquer.

The closed coating of the PREMIUM\*\*\* paper sheets delivers an excellent surface finish.

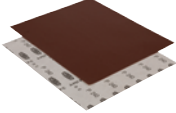
	Shape	Type no.	Dimension	Grain	PU	
	■	Sheet	706001	230x280	60	50
		706002	230x280	80	50	
		706003	230x280	100	50	
		706004	230x280	120	50	
		706005	230x280	150	50	
		706006	230x280	180	50	
		706007	230x280	220	50	
		706008	230x280	240	50	
		706009	230x280	320	50	
		706010	230x280	400	50	
		706011	230x280	600	50	
		706012	230x280	800	50	
		706013	230x280	1000	50	
		706014	230x280	1200	50	

### PREMIUM\*\*\* C-P68 P C | C-P68 P A PAPER SHEETS

For steel, nonferrous metals, wood, paints and lacquers



The paper sheets made of silicon carbide are the perfect product for preparing and machining metal, wood, paint and lacquer. The special feature of the PREMIUM\*\*\* sheets is a latex-finished backing, which makes them ideal for wet and dry finishing.

The closed coating of the PREMIUM\*\*\* paper sheets delivers an excellent surface finish.

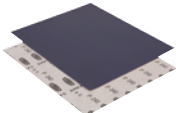
	Shape	Type no.	Dimension	Grain	PU	
	■	Sheet	724257	230x280	80	50
		724264	230x280	100	50	
		724267	230x280	120	50	
		724268	230x280	150	50	
		724271	230x280	180	50	
		724272	230x280	220	50	
		724273	230x280	240	50	
		724275	230x280	320	50	

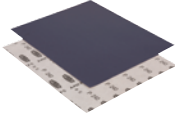

	Shape	Type no.	Dimension	Grain	PU	
	■	Sheet	724276	230x280	400	50
			724281	230x280	600	50
			724283	230x280	800	50
			724284	230x280	1000	50
			724285	230x280	1200	50

### BASIC★ A-B35 P C | A-B35 P A

#### PAPER SHEETS

For paints, lacquers and wood



With a semi-open grain distribution on a lightweight paper backing, TYROLIT paper sheets are ideal for dry grinding. This enables use on different types of wood, paints and lacquers.

The semi-open coating of the BASIC\* paper sheets prevents loading of the product and delivers an excellent surface finish.

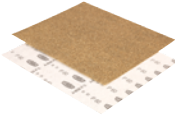
	Shape	Type no.	Dimension	Grain	PU	
	■	Sheet	706015	230x280	60	50
			706016	230x280	80	50
			706018	230x280	100	50
			706020	230x280	120	50
			706021	230x280	150	50
			706022	230x280	180	50
			706023	230x280	240	50

### BASIC★ A-B01 C JX CLOTH SHEETS

#### Universal use



With the flexible cloth sheets from TYROLIT you can machine almost any material. When finishing surfaces, preparation either by hand or using an orbital sander is required. When machining wood, paint and lacquer, TYROLIT recommends BASIC\* cloth sheets.

However, our products can also be used for finishing coatings, or smoothing and cleaning composites.

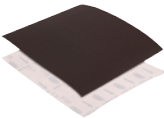
	Shape	Type no.	Dimension	Grain	PU	
	■	Sheet	705989	230x280	40	50
			705990	230x280	60	50
			705991	230x280	80	50
			705992	230x280	100	50
			705993	230x280	120	50
			705994	230x280	150	50

**BASIC★ A-B01 C JX CLOTH SHEETS**

Universal use



With the flexible cloth sheets from TYROLIT you can machine almost any material. When finishing surfaces, preparation either by hand or using an orbital sander is required. When machining wood, paint and lacquer, TYROLIT recommends BASIC★ cloth sheets.

However, our products can also be used for finishing coatings, or smoothing and cleaning composites.

	Shape		Type no.	Dimension	Grain	PU
		Sheet	705995	230x280	180	50
			705996	230x280	220	50
			705997	230x280	240	50
			705998	230x280	320	50
			705999	230x280	400	50
			706000	230x280	600	50

**BASIC★ A-B01 C JJ CLOTH SHEETS**

Universal use



With highly flexible cloth sheets from TYROLIT you can machine almost any material. When finishing surfaces, preparation either by hand or using an orbital sander is required. When machining wood, paint and lacquer, TYROLIT recommends the BASIC★ cloth sheets.

However, our products can also be used for finishing coatings, or smoothing and cleaning composites.

	Shape		Type no.	Dimension	Grain	PU
		Sheet	20832	230x280	60	50
			20833	230x280	80	50
			20834	230x280	100	50
			20835	230x280	120	50
			20836	230x280	150	50
			20842	230x280	180	50
			20844	230x280	220	50
			20851	230x280	240	50
			20860	230x280	320	50
			20868	230x280	400	50

# PREMIUM★★★ FLEECE SHEETS

## UNIVERSAL USE

### + Long lifetime

Thanks to 100% impregnation, the abrasive grain is not only located on the surface, but also inside the fleece.

### + Flexible use

The abrasive fabric adapts perfectly to any workpiece surface.



### + Universal use

The assortment offers a wide selection of possible uses on all common materials.

Our fleece sheets are used for cleaning and processing surfaces using orbital sanders or for hand-guided grinding. A wide range of speci-

cations offer the user a variety of surface finish options. The assortment extends from coarse specifications for cleaning weld

seams through to ultra-fine and polishing fleece.

## PREMIUM★★★ FLEECE SHEETS

Universal use



	Shape	Type no.	Dimension	Conforms to	Design	Colour	PU
	Sheet	120769	152x229	P150	A COARSE	BROWN	10
		120770	152x229	P220-240	A MEDIUM	RED-BROWN	10
		120772	152x229	P320	A FINE	RED-BROWN	10
		120774	152x229	P400-500	A VERY FINE	RED-BROWN	10
		120777	152x229	P220-240	S MEDIUM	BLACK	10
		120779	152x229	P800	C SUPERFINE	GREY	10
		120781	152x229	P400-500	A GP - GREEN	GREEN	10
		120787	152x229	-	POLISH	WHITE	10



TYROLIT

**BOSCH**  
503  
50/60 Hz 1.85 A 340 W  
10000 min<sup>-1</sup>  
and 104000021 2011  
D-70745 Leinfelden-Echterdingen



633







## **4.13 TYROLIT FAST CHANGE DUAL ACTION SANDER**





## TYROLIT FAST CHANGE FOR DUAL ACTION SANDERS

TYROLIT Fast Change discs offer a simple and convenient solution for surface treatment. Disc changes are quick and easy thanks to the Velcro fastening.

These tools are available with paper or film backings and can be used on nearly all materials. We offer discs with different numbers of holes for optimum material removal or extraction. They are easily applied to our back up pads.

The different grit sizes allow grinding from coarse to fine on ferrous and nonferrous metals and on wood, lacquers, paint and composites.

## Application recommendations



Performance level	Specification	Page	Steel	All in One	Compo- sites	Plastic	Gel coat	Wood	Hard Stone	Marble
<b>PREMIUM</b> ★★★	A-P21 P B	285, 286			●	●	●	●		
	A-P21 P C	285, 286			●	●	●	●		
	A-P22 FI	284, 285			●	●	●	●		
	ZA-P45 V	284		●						
	ZA-P45 P F	284		●						
	C-P65 P E	286, 287		●		●	●		●	●

Items with grey lettering are only available on request.

## Shapes



Disc

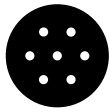

Disc 7H

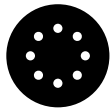

Disc 8H

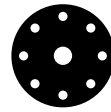

Disc 9H

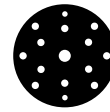

Disc 15H

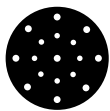

Disc 17H

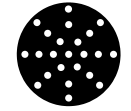

Pad TFC 23



Coated abrasives

**PREMIUM★★★ ZA-P45 V | ZA-P45 P F TFC**  
 Universal use



TYROLIT FAST CHANGE enables you to change a disc very quickly thanks to the Velcro fastening. A unique, strong paper backing combined with zirconium makes this product extremely abrasive and durable, and active coolants enable cool, clean grinding to be performed on the workpiece.

Thanks to the thin fibre backing with grit 40 and strong paper backing the TFC is the optimal tool for removing smaller welding and spot weld seams.





	Shape	Type no.	Diameter	Grain	Holes	Max. RPM	PU
	 Disc	706139	125	40	0	10,500	50
		706141	125	60	0	10,500	50
		706142	125	80	0	10,500	50
		706143	125	120	0	10,500	50
		706144	150	60	0	8,800	50
		706145	150	80	0	8,800	50
		706146	150	120	0	8,800	50

**PREMIUM★★★ A-P22 FI TFC**  
 For plastic, composites, gel coat and wood





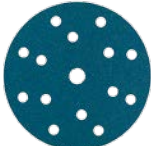

TYROLIT FAST CHANGE enables you to change a disc very quickly thanks to the Velcro fastening. This durable and flexible product has been developed with a special film backing to achieve improved edge stability and stock removal rate.

The product delivers an exceptionally even finish on lacquers, paints and composites. Clogging and loading of the disc is reduced, thus increasing the product's lifetime.

	Shape	Type no.	Diameter	Grain	Holes	Max. RPM	PU
	 Disc 8H	706147	125	40	8	10,500	50
		706148	125	60	8	10,500	50
		706149	125	80	8	10,500	50
		706150	125	100	8	10,500	50
		706151	125	120	8	10,500	50
		706152	125	150	8	10,500	50
		706154	125	180	8	10,500	50
		706155	125	240	8	10,500	50
		706157	125	320	8	10,500	50
		706158	125	400	8	10,500	50
	 Disc 15H	34063266	150	40	15	8,800	50
		34063267	150	60	15	8,800	50
		34063292	150	80	15	8,800	50
		34063294	150	100	15	8,800	50
		34063296	150	120	15	8,800	50
		34063298	150	150	15	8,800	50
		34063299	150	180	15	8,800	50

Coated abrasives

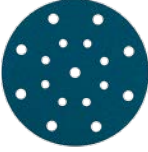

	Shape	Type no.	Diameter	Grain	Holes	Max. RPM	PU
		Disc 15H 34063300	150	240	15	8,800	50
		34063301	150	320	15	8,800	50
		34063303	150	400	15	8,800	50
		Disc 17H 34036456	150	40	17	8,800	50
		34036457	150	60	17	8,800	50
		34036458	150	80	17	8,800	50
		34036459	150	100	17	8,800	50
		34036460	150	120	17	8,800	50
		34036501	150	150	17	8,800	50
		34036502	150	180	17	8,800	50
		34036503	150	240	17	8,800	50
		34036504	150	320	17	8,800	50
		34036505	150	400	17	8,800	50

**PREMIUM★★★ A-P21 P C | A-P21 P B TFC**





For plastic, composites, gel coat and wood

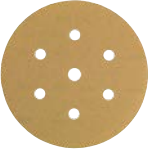

TYROLIT FAST CHANGE enables you to change a disc very quickly thanks to the Velcro fastening. The thin paper backing makes the disc ideal for finishing various wood surfaces and for preparing paint, lacquer or wax surfaces.

The product delivers an exceptionally even finish on lacquers, paints and

composites. Clogging and loading of the disc is reduced, thus increasing the product's lifetime.

	Shape	Type no.	Diameter	Grain	Holes	Max. RPM	PU
		Disc 8H 706219	125	40	8	10,500	50
		706221	125	60	8	10,500	50
		706222	125	80	8	10,500	50
		706223	125	100	8	10,500	50
		706224	125	120	8	10,500	50
		706225	125	150	8	10,500	50
		706226	125	180	8	10,500	50
		706227	125	240	8	10,500	50
		706228	125	320	8	10,500	50
		706229	125	400	8	10,500	50
		Disc 706244	150	40		8,800	50
		706245	150	60		8,800	50
		706246	150	80		8,800	50
		706248	150	120		8,800	50
		706250	150	180		8,800	50
		706251	150	240		8,800	50

**PREMIUM★★★ A-P21 P C | A-P21 P B TFC**

For plastic, composites, gel coat and wood



TYROLIT FAST CHANGE enables you to change a disc very quickly thanks to the Velcro fastening. The thin paper backing makes the disc ideal for finishing various wood surfaces and for preparing paint, lacquer or wax surfaces.

The product delivers an exceptionally even finish on lacquers, paints and

composites. Clogging and loading of the disc is reduced, thus increasing the product's lifetime.

	Shape	Type no.	Diameter	Grain	Holes	Max. RPM	PU	
		Disc 7H	706255	150	40	7	8,800	50
		706258	150	60	7	8,800	50	
		706259	150	80	7	8,800	50	
		706260	150	100	7	8,800	50	
		706261	150	120	7	8,800	50	
		706262	150	150	7	8,800	50	
		706264	150	180	7	8,800	50	
		706265	150	240	7	8,800	50	
		706266	150	320	7	8,800	50	
		Disc 9H	706268	150	40	9	8,800	50
		706269	150	60	9	8,800	50	
		706270	150	80	9	8,800	50	
		706272	150	100	9	8,800	50	
		706273	150	120	9	8,800	50	
		706274	150	150	9	8,800	50	
		706276	150	180	9	8,800	50	
		706277	150	240	9	8,800	50	
		706278	150	320	9	8,800	50	
		706280	150	400	9	8,800	50	

**PREMIUM★★★ C-P65 P E TFC**

For hard stone, steel, composites, plastics and soft stone.





TYROLIT FAST CHANGE enables you to change a disc very quickly thanks to the Velcro fastening. The thin paper backing makes the disc ideal for finishing tasks. The product delivers an exceptionally even finish on metals, lacquers, composites, marble and stone.

The product delivers an exceptionally even finish on hard stone, steel and composites. Clogging and loading of the disc is reduced, thus increasing the product's lifetime.

	Shape	Type no.	Diameter	Grain	Holes	Max. RPM	PU	
		Disc	6957	125	40	0	10,500	50
		6958	125	60	0	10,500	50	
		6960	125	80	0	10,500	50	
		6964	125	120	0	10,500	50	

Coated abrasives

	Shape	Type no.	Diameter	Grain	Holes	Max. RPM	PU	
		Disc	6968	125	180	0	10,500	50
		6969	125	220	0	10,500	50	
		6979	125	320	0	10,500	50	
		6991	125	400	0	10,500	50	
		6993	125	600	0	10,500	50	
		7007	125	800	0	10,500	50	
		7008	180	40	0	7,300	50	
		7030	180	60	0	7,300	50	
		7055	180	80	0	7,300	50	
		7058	180	120	0	7,300	50	
		7070	180	180	0	7,300	50	
		7072	180	220	0	7,300	50	
		7086	180	320	0	7,300	50	
		7087	180	400	0	7,300	50	
		7093	180	600	0	7,300	50	
7100	180	800	0	7,300	50			



**PREMIUM★★★ ACCESSORIES**

For TFC



Our back up pads can be used on most dual action sanders and their medium density provides the ideal support for finishing and preparing surfaces. The specially developed product design delivers outstanding dust extraction.

You can use practically any disc with our back up pads. They fit discs with 0, 6, 7, 9 and 15 holes.

	Shape	Type no.	Diameter	Grain	Holes	Grade	Max. RPM	PU	Design
		PAD TFC	710006	115	M14	HARD	13,300	5	
		710007	125	M14	HARD	12,300	5		
		710008	150	5/16-M8	23	HARD	10,500	1	Suitable for discs with 0, 6, 7, 9 and 15 holes
		710009	150	5/16-M8	23	MEDIUM	10,500	1	Suitable for discs with 0, 6, 7, 9 and 15 holes





**TYROLIT**

**TYROLIT**  
★★★  
PREMIUM  
100x100x19.1  
A 150  
C 400/150  
009010603547  
MAX RPM 6800





## **4.14 ROLLERS** BURNISHING MACHINE



## ROLLERS FOR BURNISHING MACHINES

TYROLIT rollers are used on portable equipment such as burnishing machines for general grinding jobs, cleaning, finishing and for polishing uneven or curved surfaces.



Our products allow a consistent, high-quality surface finish throughout their lifetime. With our comprehensive assortment, we offer products for removing welding tracks, scratches or oxidation residues. These tools

are especially popular for surface pre-treatment over large areas.



The patented shape of the newly developed spiral rollers means they are extremely easy and convenient

to use without lateral deflection. You can also increase your productivity by avoiding typical roller imprinting on the workpiece. In addition, vibrations are considerably reduced and the load is minimised.



## Application recommendation

Performance line	Pages	 Steel	 Stainless steel	 NF metals
ROLLERS <b>PREMIUM★★★</b>	292	•	•	•

Performance line	Pages	 Steel	 Stainless steel	 NF metals
SPIRAL ROLLERS <b>PREMIUM★★★</b>	293	•	•	•

Performance line	Pages	 Steel	 Stainless steel	 Plastic
ROUGH GRINDING WHEEL <b>PREMIUM★★★</b>	294	•	•	•

Items with grey lettering are only available on request.

## Shapes



1LA C



1LA VL

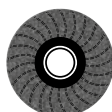

1LA VL-C

**PREMIUM★★★ ROLLERS**

For steel, stainless steel and nonferrous metals



PREMIUM\*\*\* rollers are used on burnishing machines for general grinding processes, cleaning, finishing and for polishing uneven or curved surfaces. As the wear pattern remains stable throughout the product lifetime, a consistent high-quality surface finish is delivered. The comprehensive assortment offers products for removing welding

tracks, scratches and oxidation residue, as well as for pre-treating surfaces.

	Shape	Type no.	Dimension	Grain	Design	Colour	Max. RPM	Rec. speed	PU	
		1LA C	62144	100x100x19.1 S4	40		6,800	3,700	1	
			62153	100x100x19.1 S4	60		6,800	3,700	1	
			62154	100x100x19.1 S4	80		6,800	3,700	1	
			62155	100x100x19.1 S4	120		6,800	3,700	1	
			62178	100x100x19.1 S4	180		6,800	3,700	1	
		1LA VL	60159	100x100x19.1 S4		A COARSE	RED-BROWN	6,800	2,400	1
			60170	100x100x19.1 S4		A MEDIUM	RED-BROWN	6,800	2,400	1
			60184	100x100x19.1 S4		A FINE	RED-BROWN	6,800	2,400	1
			60185	100x100x19.1 S4		A VERY FINE	RED-BROWN	6,800	2,400	1
		1LA VL-C	60337	100x100x19.1 S4	60	A COARSE	RED-BROWN	6,800	2,400	1
			60351	100x100x19.1 S4	80	A MEDIUM	GREY	6,800	2,400	1
			60352	100x100x19.1 S4	120	A FINE	GREY	6,800	2,400	1
			60354	100x100x19.1 S4	180	A VERY FINE	GREY	6,800	2,400	1

Coated abrasives



# PREMIUM\*\*\* SPIRAL ROLLERS FOR STEEL, STAINLESS STEEL AND NONFERROUS METALS

**+ Reduced working times**  
Work steps do not need to be repeated, as roller imprinting is avoided.

**+ Reduced load**  
Significantly reduced vibrations prevent damage to health.



**+ Consistent results**  
Consistent high-quality finish thanks to the stable grinding surface pattern.

The patented shape of the newly developed PREMIUM\*\*\* spiral rollers means they are extremely easy and convenient to use without lateral deflection. Using the PREMIUM\*\*\* spiral rollers significantly increases productivity by avoiding typical roller

imprinting on the workpiece. This means grinding processes do not have to be performed again.



In addition, vibrations are considerably reduced and the load is minimised. The convenient and intuitive

operation does not require extensive training to learn, meaning convincing results are achieved immediately.

## PREMIUM\*\*\* SPIRAL ROLLERS

For steel, stainless steel and nonferrous metals



	Shape	Type no.	Dimension	Grain	Design	Colour	Max. RPM	Rec. speed	PU
		1LA VL 94134	100x100x19.1 S4		A COARSE	RED-BROWN	6,800	2,400	1
		94204	100x100x19.1 S4		A MEDIUM	RED-BROWN	6,800	2,400	1
		94210	100x100x19.1 S4		A VERY FINE	RED-BROWN	6,800	2,400	1
		1LA VL-C 94223	100x100x19.1 S4	60	A COARSE	RED-BROWN	6,800	2,400	1
		94234	100x100x19.1 S4	80	A MEDIUM	GREY	6,800	2,400	1
		94237	100x100x19.1 S4	120	A FINE	GREY	6,800	2,400	1

# PREMIUM★★★ ROUGH CLEANING ROLLERS FOR STEEL, STAINLESS STEEL AND PVC

**+ Powerful**  
TYROLIT rough cleaning wheels are characterised by a long lifetime and an excellent grinding surface pattern.



**+ Versatile tool**  
Not only for removing rust, paint, lacquer and underbody sealant, but also for preparing surfaces for welding, soldering and anodising.

**+ User-friendly**  
Enables the user to perform quiet, non-strenuous work.

With the TYROLIT rough cleaning roller for burnishing machines, you can effortlessly remove rust, paint, lacquer and underbody sealant from your

workpiece. The porous nylon fibres, treated with aggressive abrasives, meet any challenge. Particularly suitable for cleaning large, even surfaces.

At the same time, they prevent clogging or loading.

## PREMIUM★★★ ROUGH CLEANING ROLLERS

For steel, stainless steel and PVC



	Shape	Type no.	Dimension	Grain	Design	Colour	Max. RPM	Rec. speed	PU
	1GR	34077301	100x100x19.1 S4		C COARSE	BLACK	6,800	2,400	1

Coated abrasives



**4.15 ROLLERS**  
FLOORSTANDING GRINDER





## ROLLERS FOR FLOORSTANDING GRINDERS

TYROLIT rollers are used on stationary machines such as floorstanding grinders for general grinding jobs, cleaning, finishing and for polishing uneven or curved surfaces.

Our products allow a consistent, high-quality surface finish throughout their lifetime. With our comprehensive assortment, we offer products for

removing welding tracks, scratches or oxidation residues. These tools are especially popular for surface pre-treatment over large areas.

Rollers for floorstanding grinders are available in many different grain sizes and so always produce the desired result.



## Application recommendation



Performanceline	Pages	Steel	Stainless steel	NF metals
<b>PREMIUM</b> ***	298, 299	•	•	•

Items with grey lettering are only available on request.

## Shapes



1 LA C



**PREMIUM★★★ ROLLERS**

For steel, stainless steel and nonferrous metals



PREMIUM\*\*\* rollers for bench grinders can be used for general grinding processes, including cleaning, finishing and for polishing uneven or curved surfaces. As the wear pattern remains stable throughout the product life-time, a consistent high-quality surface finish is delivered.

The comprehensive assortment offers products for removing welding tracks, scratches and oxidation residue, as well as for pre-treating surfaces.

Shape	Type no.	Shape	Dimension	Grain	Max. RPM	Rec. speed	PU
 	1LA C 62180	1LA	165x25x25.4	40	5,200	3,300	2
	62181	1LA	165x25x25.4	60	5,200	3,300	2
	62190	1LA	165x25x25.4	80	5,200	3,300	2
	62194	1LA	165x25x25.4	120	5,200	3,300	2
	62197	1LA	165x25x25.4	150	5,200	3,300	2
	62202	1LA	165x25x25.4	180	5,200	3,300	2
	62212	1LA	165x25x25.4	220	5,200	3,300	2
	62239	1LA	165x25x25.4	320	5,200	3,300	2
	62258	1LA	165x30x54	40	5,200	3,300	2
	62274	1LA	165x30x54	60	5,200	3,300	2
	62277	1LA	165x30x54	80	5,200	3,300	2
	62291	1LA	165x30x54	100	5,200	3,300	2
	62298	1LA	165x30x54	120	5,200	3,300	2
	62299	1LA	165x30x54	150	5,200	3,300	2
	62304	1LA	165x30x54	180	5,200	3,300	2
	62332	1LA	165x30x54	220	5,200	3,300	2
	62334	1LA	165x30x54	240	5,200	3,300	2
	62342	1LA	165x30x54	320	5,200	3,300	2
	62353	1LA	165x50x54	40	5,200	3,300	1
	62384	1LA	165x50x54	50	5,200	3,300	1
	62409	1LA	165x50x54	60	5,200	3,300	1
	62416	1LA	165x50x54	80	5,200	3,300	1
	62419	1LA	165x50x54	100	5,200	3,300	1
	62434	1LA	165x50x54	120	5,200	3,300	1
	62436	1LA	165x50x54	150	5,200	3,300	1
	62437	1LA	165x50x54	180	5,200	3,300	1
	62448	1LA	165x50x54	220	5,200	3,300	1
	62453	1LA	165x50x54	240	5,200	3,300	1
62471	1LA	165x50x54	320	5,200	3,300	1	

Coated abrasives

	Shape	Type no.	Shape	Dimension	Grain	Max. RPM	Rec. speed	PU
	1LA C	62484	1LA	200x50x54	40	3,800	2,600	1
		62491	1LA	200x50x54	60	3,800	2,600	1
		62505	1LA	200x50x54	80	3,800	2,600	1
		62506	1LA	200x50x54	100	3,800	2,600	1
		62507	1LA	200x50x54	180	3,800	2,600	1
		62516	1LA	200x50x54	320	3,800	2,600	1
		62518	1LA	250x50x100	60	3,000	2,000	1
		62521	1LA	250x50x100	80	3,000	2,000	1
		62524	1LA	250x50x100	100	3,000	2,000	1
		62547	1LA	250x50x100	120	3,000	2,000	1
		62548	1LA	250x50x100	220	3,000	2,000	1

**PREMIUM★★★ ACCESSORIES**

For rollers

These reduction bushes can be used for bench grinder roller applications. With this set, you have the option of reducing the original bore diameter to 32, 25, 22, 20, 16 or 12 millimetres.

	Shape	Type no.	Dimension	Design	PU
		27	34024028	54x32	Reduction from 54 to 32, 1
					25, 22, 20, 16, 12







# CATALOGUE 18

## DIAMOND TOOLS

<b>Grinding information</b>	<b>302</b>
Explanation of labels	302
Colour codes	302
Specification	303
Machine pictograms	303
<b>Angle grinder</b>	<b>305</b>
5.1 Dry cutting saw blades	306
5.2 Diamond cup wheels	317
<b>Petrol cutting saw</b>	<b>323</b>
5.3 Dry cutting saw blades	324
<b>Floor saw</b>	<b>335</b>
5.4 Diamond saws	336
<b>Table saws</b>	<b>341</b>
5.5 Diamond saws	342
<b>Core drilling</b>	<b>347</b>
5.6 Dry drill bits	348
5.7 Wet drill bits	355
<b>TYROLIT machines</b>	<b>365</b>
5.8 Overview	366

# SPECIFIC INFORMATION

## DIAMOND TOOLS

### Product label



Registered trademark

Max. speed

Quality line

Application and safety pictograms

TYROLIT, founding member of oSa®

Specification

Dimensions: external x internal Ø

Segment height and length

Type number

Material suitability

### Colour codes



<b>Label</b>	Universal	Concrete	Hard stone	Tiles	Marble	Asphalt	Abrasive materials
<b>Colour code</b>	yellow	red	blue	green	green	grey	grey
<b>Material</b>	Universal building materials	Concrete	Hard stone	Tiles, ceramic materials	Soft stone, marble	Abrasive materials	Abrasive materials

## Specification

### DCAB★★★-FC

			<b>FC</b>	FASTCUT
			<b>S</b>	SILENT
			<b>LL</b>	LOGLIFE
		<b>★★★</b>		PREMIUM***
		<b>★★</b>		STANDARD**
		<b>★</b>		BASIC*
	<b>AB</b>			Abrasive materials
	<b>U</b>			Universal building materials
	<b>C</b>			Concrete
	<b>H</b>			Hard stone
	<b>A</b>			Asphalt
	<b>M</b>			Marble, soft stone
	<b>T</b>			Tiles, ceramics
<b>DC</b>				Dry cutting

## Machines



Angle grinder



Floor saw



Petrol cutting saw



Table saw



Wet core bit



Dry core bit









**5.1 DRY CUTTING SAW BLADES**  
ANGLE GRINDER



## DRY-CUTTING SAW BLADES FOR ANGLE GRINDERS

TYROLIT provides laser welded and directly sintered dry-cutting saw blades that meet the highest standards of quality and safety.

With TYROLIT dry cutting saw blades, plastics, fibreglass or bullet-proof glass can be machined in addition to countless standard materials, such as hard stone, concrete or asphalt. Innovative products, such as ultra-thin and sound-insulated dry cutting saw blades, underline the continuous further development and optimisation of diamond products.

### TGD® technology

TGD® (TYROLIT GRAIN DISTRIBUTION) is a unique technology developed by Tyrolit, which ensures consistently fast cutting rates, an extremely long lifetime and noticeable smooth running through optimised grain distribution. This provides for clean cuts that require no reworking. Furthermore, significantly less vibration is generated, resulting in less strain on the operator and the

machine. These advantages are particularly economically evident in continuous operation: The operator can distribute his effort evenly over the day and machines remain serviceable longer.



### Shapes



**1A1R**  
Dry cutting saw blade



**C3/C3W**  
Dry cutting saw blade



**C6/C6W**  
Dry cutting saw blade



**UC3**  
Dry cutting saw blade



**C6R**  
Dry cutting saw blade



**C3S/C3SW**  
Dry cutting saw blade



**C3R**  
Dry cutting saw blade

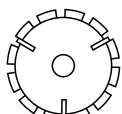

**FRSU**  
Dry cutting saw blade

Diamond tools



## Application recommendation



Performance level	Specification	Pages	Universal	Concrete	Hard stone	Abrasive materials	Soft stone	Tiles
<b>PREMIUM***</b>	DCU*** 4in1 TGD 4in1	308	●					
	DCU***	309	●					
	DCU***- FC 4in1 FASTCUT	309	●					
	DCU***-S SILENT	309	●					
	DCC***	310		●				
	DCC*** FC FASTCUT	310		●				
	DCH***	312				●		
	DCH*** TGD	311				●		
	DCH***-FC FASTCUT	312				●		
	DCAB***	313					●	
	DCM***	313						●
	DCT***	312						



Performance level	Specification	Pages	Universal	Concrete
<b>STANDARD**</b>	DCU**	314	●	
	DCU** FC FASTCUT	314	●	
	DCC**	314		●



Performance level	Specification	Pages	Universal	Hard stone	Abrasive materials	Tiles
<b>BASIC*</b>	DCU*	315	●			
	DCU*-FC FASTCUT	315	●			
	DCH*	315		●		
	DCAB*	316				●
	DCT*	316				

Items with grey lettering are only available on request.

# PREMIUM★★★ DRY CUTTING SAW BLADE DCU★★★ 4IN1-TGD

+ **Low cutting costs**  
because of high  
cutting speed

+ **Universal use**  
on concrete, hard stone,  
abrasive materials  
and steel



+ **Consistently fast cutting performance,**  
very long lifetime and noticeable smooth running with TGD® technology (Tyrolit Grain Distribution), a unique technology developed by Tyrolit for the optimised distribution of grain

+ **Reduced load for the user**  
as a result of unique smooth running



Materials able to be machined:  
Universal building materials, such as concrete, natural stone, clay brick, cellular concrete, etc. Details: the DCU★★★4in1 dry cutting saw blade

impresses with excellent results when cutting concrete, hard stone, abrasive materials and steel.  
The possibility for universal use offers the user a product which is ready-

to-use at any time without a wheel change and ensures the successful completion of a project.

## PREMIUM★★★ DRY CUTTING SAW BLADE DCU★★★ 4in1



	Shape	Type no.	Dimension	Segment height	Classification
		C3W 704617	230x2.4x22.23	14	4in1



**PREMIUM\*\*\* DRY CUTTING SAW BLADE**  
DCU\*\*\*



Materials able to be machined: Universal building materials, such as concrete, clay brick, natural stone, steel, etc. TYROLIT provides laser welded and directly sintered dry cutting saws that meet the highest quality and safety standards.  
With TYROLIT dry cutting saws, even plastics, fibreglass or bullet-proof

glass can be machined in addition to countless standard materials, such as hard stone, concrete or asphalt. Innovative products, such as ultra-thin and sound-insulated dry cutting saw blades, underline the continuous further development and optimisation of diamond products.

	Shape	Type no.	Dimension	Segment height
		C6W 464537	115x2.2x22.23	10
		464539	125x2.2x22.23	10
		464540	150x2.4x22.23	12
		464543	180x2.4x22.23	12
		464544	230x2.4x22.23	12

**PREMIUM\*\*\* DRY CUTTING SAW BLADE**  
DCU\*\*\*-FC 4in1



Materials able to be machined: Universal building materials, such as concrete, clay brick, natural stone, steel, etc. TYROLIT provides laser welded and directly sintered dry cutting saws that meet the highest quality and safety standards.  
With TYROLIT dry cutting saws, even plastics, fibreglass or bullet-proof

glass can be machined in addition to countless standard materials, such as hard stone, concrete or asphalt. Innovative products, such as ultra-thin and sound-insulated dry cutting saw blades, underline the continuous further development and optimisation of diamond products.

	Shape	Type no.	Dimension	Segment height	Classification
		C6R 474743	115x2x22.23	10	FASTCUT 4in1
		474746	125x2x22.23	10	FASTCUT 4in1
		474751	150x2.4x22.23	9	FASTCUT 4in1
		474752	180x2.4x22.23	9	FASTCUT 4in1
		474753	230x2.4x22.23	9	FASTCUT 4in1

**PREMIUM\*\*\* DRY CUTTING SAW BLADE**  
DCU\*\*\*-S



Materials able to be machined: Universal building materials, such as concrete, clay brick, natural stone, steel, etc. TYROLIT provides laser welded and directly sintered dry cutting saws that meet the highest quality and safety standards.  
With TYROLIT dry cutting saws, even plastics, fibreglass or bullet-proof

glass can be machined in addition to countless standard materials, such as hard stone, concrete or asphalt. Innovative products, such as ultra-thin and sound-insulated dry cutting saw blades, underline the continuous further development and optimisation of diamond products.

	Shape	Type no.	Dimension	Segment height	Classification
		C2G 474771	230x2.6x22.23	9	SILENT



Diamond tools

**PREMIUM\*\*\* DRY CUTTING SAW BLADE**  
DCC\*\*\*



Materials able to be machined: concrete, reinforced concrete, concrete products, hard materials, etc. TYROLIT provides laser welded and directly sintered dry cutting saws that meet the highest quality and safety standards.  
With TYROLIT dry cutting saws, even plastics, fibreglass or bullet-proof

glass can be machined in addition to countless standard materials, such as hard stone, concrete or asphalt. Innovative products, such as ultra-thin and sound-insulated dry cutting saw blades, underline the continuous further development and optimisation of diamond products.



	Shape	Type no.	Dimension	Segment height	
		C6W	465488	115x2.2x22.23	10
			465489	125x2.2x22.23	10
			465490	150x2.4x22.23	12
			465491	180x2.4x22.23	12
			465492	230x2.4x22.23	12

**PREMIUM\*\*\* DRY CUTTING SAW BLADE**  
DCC\*\*\*-FC Wall chaser blade



Materials able to be machined: Concrete, clay brick, cellular concrete. Details: tool for the milling of slots in concrete and masonry. For use with all common wall chasers. TYROLIT provides laser welded and directly sintered dry cutting saws that meet the highest quality and safety standards.

With TYROLIT dry cutting saws, even plastics, fibreglass or bullet-proof glass can be machined in addition to countless standard materials, such as hard stone, concrete or asphalt. Innovative products, such as ultra-thin and sound-insulated dry cutting saw blades, underline the continuous further development and optimisation of diamond products.

	Shape	Type no.	Dimension	Segment height	Classification	
		C3R	598008	125x2.0x22.23	7	FASTCUT
			598010	140x2.4x22.23	9	FASTCUT
			598011	150x2.4x22.23	9	FASTCUT

# PREMIUM★★★ DRY CUTTING SAW BLADE DCH★★★-TGD

+ **Low cutting costs**  
because of high  
cutting speed

+ **Reduced load for the user**  
as a result of unique smooth  
running

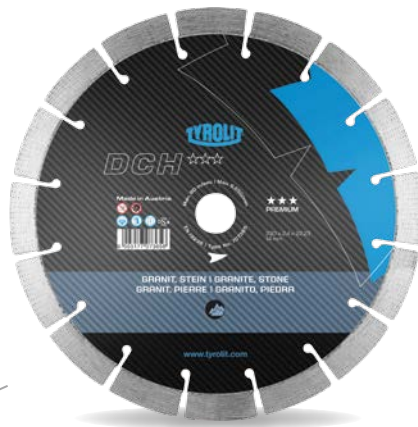

+ **Consistently fast cutting performance,**  
very long lifetime and no-  
ticeable smooth running with  
TGD® technology (Tyrolit Grain  
Distribution), a unique technol-  
ogy developed by Tyrolit for the  
optimised distribution of grain

+ **No reworking**  
due to very clean  
cutting edges



Details: the DCH\*\*\* dry cutting saw blade, specially developed using TGD® technology for hard stone, impresses with its cutting ability and smooth running. Reduced effort over

the entire lifetime allows for higher productivity. The perfectly optimised segments for the application create very clean, chip-free edges and ensure a flawless result.

Materials able to be machined:  
Concrete blocks, granite, gneiss,  
porphyry, paving slab, etc.

## PREMIUM★★★ DRY CUTTING SAW BLADE DCH\*\*\*-TGD





	Shape	Type no.	Dimension	Segment height
		C3W 707365	230x2.4x22.23	14

**PREMIUM\*\*\* DRY CUTTING SAW BLADE**  
DCH\*\*\*



Materials able to be machined: Granite, gneiss, porphyry, paving slab, hard limestone, etc. TYROLIT provides laser welded and directly sintered dry cutting saws that meet the highest quality and safety standards. With TYROLIT dry cutting saws, even plastics, fibreglass or bullet-proof glass can be machined in addition to countless standard materials, such as

hard stone, concrete or asphalt. Innovative products, such as ultra-thin and sound-insulated dry cutting saw blades, underline the continuous further development and optimisation of diamond products.



	Shape	Type no.	Dimension	Segment height
		C6W 464697	115x2.2x22.23	10
		464698	125x2.2x22.23	10
		464699	150x2.4x22.23	12

**PREMIUM\*\*\* DRY CUTTING SAW BLADE**  
DCH\*\*\*-FC



The DCH\*\*\*-FC from TYROLIT enables the user to carry out cutting work swiftly and to precise dimensions, without any great exertion. The DCH\*\*\*-FC is an ultra-thin diamond cut-off wheel with a segment thickness of 1.2 or 1.9 mm. It is distinguished by an extremely high cutting ability with minimal dust generation and extremely smooth running. TYROLIT provides laser welded and directly sintered dry cutting saws that meet the highest quality and safety standards. With TYROLIT dry cutting

saws, even plastics, fibreglass or bullet-proof glass can be machined in addition to countless standard materials, such as hard stone, concrete or asphalt. Innovative products, such as ultra-thin and sound-insulated dry cutting saw blades, underline the continuous further development and optimisation of diamond products.



	Shape	Type no.	Dimension	Segment height	Classification
		C3 475790	115x1.2x22.23	7	FASTCUT
		475793	125x1.2x22.23	7	FASTCUT
		C3W 475797	180x1.9x22.23	9	FASTCUT
		475800	230x1.9x22.23	9	FASTCUT

**PREMIUM\*\*\* DRY CUTTING SAW BLADE**  
DCT\*\*\*



Materials able to be machined: Ceramic tile, fine stoneware, porcelain. Details: A 20-16 mm reduction bush is supplied with a disc diameter of 105 mm. TYROLIT provides laser welded and directly sintered dry cutting saws that meet the highest quality and safety standards. With TYROLIT dry cutting saws, even plastics, fibreglass or bullet-proof

glass can be machined in addition to countless standard materials, such as hard stone, concrete or asphalt. Innovative products, such as ultra-thin and sound-insulated dry cutting saw blades, underline the continuous further development and optimisation of diamond products.

	Shape	Type no.	Dimension	Segment height
		1A1R 639558	105x1.2x20	10
		639559	115x1.2x22.23	10
		639560	125x1.2x22.23	10
		676791	200x1.6x22.23	10
		639635	230x1.6x22.23	10

Diamond tools



**PREMIUM\*\*\* DRY CUTTING SAW BLADE**  
DCM\*\*\*



Materials able to be machined: marble, fibreglass reinforced plastic, PVC, carbon fibre, composites, fibreglass, bulletproof glass, etc. Details: with electroplated coating, also suitable for rescue operations. TYROLIT provides laser welded and directly sintered dry cutting saws that meet the highest quality and safety standards.

With TYROLIT dry cutting saws, even plastics, fibreglass or bullet-proof glass can be machined in addition to countless standard materials, such as hard stone, concrete or asphalt. Innovative products, such as ultra-thin and sound-insulated dry cutting saw blades, underline the continuous further development and optimisation of diamond products.

	Shape	Type no.	Dimension	Segment height	
		UC3	315968	115x2.5x22.23	2
			315967	125x2.5x22.23	2
			547611	150x3.0x22.23	2
			315966	180x3.0x22.23	2
			315965	230x3.0x22.23	2

**PREMIUM\*\*\* DRY CUTTING SAW BLADE**  
DCAB\*\*\*



Materials able to be machined: abrasive concrete, cellular concrete, floor pavement, plaster, pumice stone, etc. TYROLIT provides laser welded and directly sintered dry cutting saws that meet the highest quality and safety standards.

With TYROLIT dry cutting saws, even plastics, fibreglass or bullet-proof glass can be machined in addition to countless standard materials, such as hard stone, concrete or asphalt. Innovative products, such as ultra-thin and sound-insulated dry cutting saw blades, underline the continuous further development and optimisation of diamond products.

	Shape	Type no.	Dimension	Segment height	
		C3W	465976	115x2.2x22.23	10
			465977	125x2.2x22.23	10
			465979	150x2.2x22.23	10
		C3SW	465980	230x2.4x22.23	10

**PREMIUM\*\*\* DRY CUTTING SAW BLADE**  
DCAB\*\*\* tuck point blade



Materials able to be machined: mortar joints. Details: tool for milling and repairing mortar joints. TYROLIT provides laser welded and directly sintered dry cutting saws that meet the highest quality and safety standards. With TYROLIT dry cutting saws, even plastics, fibreglass or bullet-proof glass can be machined in addition to countless standard materials, such

as hard stone, concrete or asphalt. Innovative products, such as ultra-thin and sound-insulated dry cutting saw blades, underline the continuous further development and optimisation of diamond products.



	Shape	Type no.	Dimension	Segment height	
		FRSU	563873	115x7.2x22.23	7
			535829	125x7.2x22.23	7

**STANDARD\*\* DRY CUTTING SAW BLADE**  
DCU\*\*



Materials able to be machined: Universal building materials, such as concrete, clay brick, natural stone, steel, etc. TYROLIT provides laser welded and directly sintered dry cutting saws that meet the highest quality and safety standards.  
With TYROLIT dry cutting saws, even plastics, fibreglass or bullet-proof

glass can be machined in addition to countless standard materials, such as hard stone, concrete or asphalt. Innovative products, such as ultra-thin and sound-insulated dry cutting saw blades, underline the continuous further development and optimisation of diamond products.



	Shape	Type no.	Dimension	Segment height	
		C3	467443	115x2.0x22.23	7
			467444	125x2.0x22.23	7
			467445	150x2.6x22.23	9
			467446	180x2.6x22.23	9
			467448	230x2.6x22.23	9

**STANDARD\*\* DRY CUTTING SAW BLADE**  
DCU\*\*-FC



Materials able to be machined: Universal building materials, such as concrete, clay brick, natural stone, steel, etc. TYROLIT provides laser welded and directly sintered dry cutting saws that meet the highest quality and safety standards.  
With TYROLIT dry cutting saws, even plastics, fibreglass or bullet-proof

glass can be machined in addition to countless standard materials, such as hard stone, concrete or asphalt. Innovative products, such as ultra-thin and sound-insulated dry cutting saw blades, underline the continuous further development and optimisation of diamond products.



	Shape	Type no.	Dimension	Segment height	Classification	
		C3R	467414	115x2.0x22.23	7	FASTCUT
			467416	125x2.0x22.23	7	FASTCUT
			467428	150x2.4x22.23	9	FASTCUT
			467430	180x2.4x22.23	9	FASTCUT
			467431	230x2.4x22.23	9	FASTCUT

**STANDARD\*\* TROCKENSCHNITTSÄGE**  
DCC\*\*



Materials able to be machined: concrete, reinforced concrete, concrete products, hard materials, etc. TYROLIT provides laser welded and directly sintered dry cutting saws that meet the highest quality and safety standards.  
With TYROLIT dry cutting saws, even plastics, fibreglass or bullet-proof

glass can be machined in addition to countless standard materials, such as hard stone, concrete or asphalt. Innovative products, such as ultra-thin and sound-insulated dry cutting saw blades, underline the continuous further development and optimisation of diamond products.

	Shape	Type no.	Dimension	Segment height	
		C3	474774	115x2.0x22.23	7
			474775	125x2.0x22.23	7
			536789	130x2.2x22.23	7
			474777	150x2.6x22.23	9
			474778	180x2.6x22.23	9
			474780	230x2.6x22.23	9

Diamond tools

**BASIC★ DRY CUTTING SAW BLADE**  
DCU\*



Materials able to be machined: Universal building materials, such as concrete, clay brick, natural stone, etc. Details: A 20-16 mm reduction bush is supplied with a disc diameter of 105 mm. TYROLIT provides laser welded and directly sintered dry cutting saws that meet the highest quality and safety standards.

With TYROLIT dry cutting saws, even plastics, fibreglass or bullet-proof glass can be machined in addition to countless standard materials, such as hard stone, concrete or asphalt. Innovative products, such as ultra-thin and sound-insulated dry cutting saw blades, underline the continuous further development and optimisation of diamond products.

	Shape	Type no.	Dimension	Segment height	
		C3	466082	105x2.0x20	7
			466083	115x2.0x22.23	7
			466084	125x2.6x22.23	7
			466086	150x2.6x22.23	9
			466087	180x2.6x22.23	9
			466090	230x2.6x22.23	9

**BASIC★ DRY CUTTING SAW BLADE**  
DCU\*-FC



Materials able to be machined: Universal building materials, such as concrete, clay brick, natural stone, etc. Details: A 20-16 mm reduction bush is supplied with a disc diameter of 105 mm. TYROLIT provides laser welded and directly sintered dry cutting saws that meet the highest quality and safety standards.

With TYROLIT dry cutting saws, even plastics, fibreglass or bullet-proof glass can be machined in addition to countless standard materials, such as hard stone, concrete or asphalt. Innovative products, such as ultra-thin and sound-insulated dry cutting saw blades, underline the continuous further development and optimisation of diamond products.

	Shape	Type no.	Dimension	Segment height	Classification	
		C3R	467266	105x2.0x20	7	FASTCUT
			467267	115x2.0x22.23	7	FASTCUT
			467268	125x2.0x22.23	7	FASTCUT
			467271	150x2.4x22.23	9	FASTCUT
			467273	180x2.4x22.23	9	FASTCUT
			467276	230x2.4x22.23	9	FASTCUT

**BASIC★ DRY CUTTING SAW BLADE**  
DCH\*



Materials able to be machined: Granite, porphyry, paving slab, hard limestone, etc. TYROLIT provides laser welded and directly sintered dry cutting saws that meet the highest quality and safety standards.

as hard stone, concrete or asphalt. Innovative products, such as ultra-thin and sound-insulated dry cutting saw blades, underline the continuous further development and optimisation of diamond products.

With TYROLIT dry cutting saws, even plastics, fibreglass or bullet-proof glass can be machined in addition to countless standard materials, such

	Shape	Type no.	Dimension	Segment height	
		C3	467386	115x2.0x22.23	7
			467387	125x2.0x22.23	7
			467388	180x2.6x22.23	9
			467389	230x2.6x22.23	9



**BASIC★ DRY CUTTING SAW BLADE**  
DCAB\*



Materials able to be machined: abrasive concrete, cellular concrete, floor pavement, plaster, pumice stone, etc. TYROLIT provides laser welded and directly sintered dry cutting saws that meet the highest quality and safety standards.

With TYROLIT dry cutting saws, even plastics, fibreglass or bullet-proof

glass can be machined in addition to countless standard materials, such as hard stone, concrete or asphalt. Innovative products, such as ultra-thin and sound-insulated dry cutting saw blades, underline the continuous further development and optimisation of diamond products.

	Shape	Type no.	Dimension	Segment height
		C3W 465672	115x2.2x22.23	9
		465674	125x2.2x22.23	9
		465677	150x2.2x22.23	10
		465686	230x2.4x22.23	10



**BASIC★ DRY CUTTING SAW BLADE**  
DCT\*



Materials able to be machined: Ceramic tiles. TYROLIT provides laser welded and directly sintered dry cutting saws that meet the highest quality and safety standards.

With TYROLIT dry cutting saws, even plastics, fibreglass or bullet-proof

glass can be machined in addition to countless standard materials, such as hard stone, concrete or asphalt. Innovative products, such as ultra-thin and sound-insulated dry cutting saw blades, underline the continuous further development and optimisation of diamond products.

	Shape	Type no.	Dimension	Segment height
		1A1R 475975	100x1.6x23.23	7
		475978	115x1.6x22.23	7
		475980	125x1.6x22.23	7
		475983	180x2.0x22.23	9
		475986	230x2.0x22.23	9





## **5.2 DIAMOND CUP WHEELS** ANGLE GRINDER



## DIAMOND CUP WHEELS FOR ANGLE GRINDERS

TYROLIT diamond cup wheels enable quick and accurate grinding of uneven concrete, stone and floor pavement surfaces. In addition to their universal range of applications, high stock removal rates and a long lifetime are main characteristics of TYROLIT diamond cup wheels.

## Application recommendation



Performance level	Specification	Pages	Universal	Abrasive materials
<b>PREMIUM***</b>	DGU***	320	•	
	DGU*** Turbo	320	•	
	DGAB***	320		•



Performance level	Specification	Pages	Universal
<b>STANDARD**</b>	Single row DGU**	320	•
	Double row DGU**	320	•
	DGU** Turbo	321	•

Items with grey lettering are only available on request.

## Formen

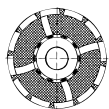

**STHD** cup wheels  
With PU foam coating

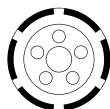

**STS-S** cup wheels  
Single row segments



**STS-D** cup wheels  
Double row segments



**STS-T** cup wheels  
Turbo segments





### PREMIUM\*\*\* DIAMOND CUP WHEEL DGU\*\*\*



Materials able to be machined: Concrete, natural stone and general building materials. Details: with PU foam coating for quiet grinding and shaping of corners and edges. TYROLIT diamond cup wheels enable quick and accurate grinding of uneven concrete, stone and floor pavement surfaces.

High stock removal rates and lifetime are at the forefront of TYROLIT diamond cup wheels, as is their universal range of application. Thorough colour coding helps you to quickly find the right product for every application.

	Shape	Type no.	Dimension	Segment height	
		STHD	356569	100x18x22.23	5
			350694	110x18x22.23	5
			367833	110x18xM14	5
			348387	125x18x22.23	5
			828013	180x19x22.23	5



### PREMIUM\*\*\* DIAMOND CUP WHEEL DGU\*\*\*-Turbo



Machinable materials: Concrete, natural stone and general building materials. Details: turbo style arranged segments for a fine grinding surface pattern and shaping of corners and edges. Quick dust removal. A 22, 23-16 mm reduction bush is supplied with a wheel diameter of 100 mm. TYROLIT diamond cup wheels enable quick and accurate grinding of

uneven concrete, stone and floor pavement surfaces.

High stock removal rates and lifetime are at the forefront of TYROLIT diamond cup wheels, as is their universal range of application. Thorough colour coding helps you to quickly find the right product for every application.



	Shape	Type no.	Dimension	Segment height	Classification	
		STS-T	598061	100x18x22.23	5	W-Segment
			34179930	125x20x22.23	5	W-Segment
			34179971	180x32x22.23	5	W-Segment

### STANDARD\*\* DIAMOND CUP WHEEL DGU\*\*-Double row



Materials able to be machined: Concrete, natural stone and general building materials. Details: double row segments for medium stock removal and long lifetime. A 22, 23-16 mm reduction bush is supplied with wheel diameters of 100 and 110 mm. TYROLIT diamond cup wheels enable quick and accurate grinding of uneven concrete, stone and floor pavement surfaces. High stock removal rates and lifetime are at the forefront of TYROLIT

diamond cup wheels, as is their universal range of application. Thorough colour coding helps you to quickly find the right product for every application.

	Shape	Type no.	Dimension	Segment height	Classification	
		STS-D	494339	100x18x22.23	5	Double row
			494349	110x32x22.23	5	Double row
			494361	125x18x22.23	5	Double row
			494394	180x20x22.23	5	Double row





**STANDARD★★ DIAMOND CUP WHEEL**

DGU\*\*-Single row



Materials able to be machined: Concrete, natural stone and general building materials. Details: single row segments for high stock removal. A 22, 23-16 mm reduction bush is supplied. TYROLIT diamond cup wheels enable quick and accurate grinding of uneven concrete, stone and floor pavement surfaces.

High stock removal rates and lifetime are at the forefront of TYROLIT diamond cup wheels, as is their universal range of application. Thorough colour coding helps you to quickly find the right product for every application.

	Shape	Type no.	Dimension	Segment height	Classification
		STS-D 494333	100x18x22.23	5	Single row



**STANDARD★★ DIAMOND CUP WHEEL**

DGU\*\*-Turbo



Machinable materials: Concrete, natural stone and general building materials. Details: turbo style arranged segments for a fine grinding surface pattern and shaping of corners and edges. Quick dust removal. A 22, 23-16 mm reduction bush is supplied with a wheel diameter of 100 mm. TYROLIT diamond cup wheels enable quick and accurate grinding of

uneven concrete, stone and floor pavement surfaces. High stock removal rates and lifetime are at the forefront of TYROLIT diamond cup wheels, as is their universal range of application. Thorough colour coding helps you to quickly find the right product for every application.

	Shape	Type no.	Dimension	Segment height	Classification
		STS-T 494342	100x18x22.23	5	Turbo
		494365	125x20x22.23	5	Turbo
		494391	180x32x22.23	5	Turbo







## **5.3 DRY CUTTING SAW BLADES** PETROL CUTTING SAW





## DRY-CUTTING SAW BLADES FOR PETROL CUTTING SAWS

TYROLIT provides laser welded and directly sintered dry-cutting saw blades that meet the highest standards of quality and safety.

With TYROLIT dry cutting saw blades, plastics, fibreglass or bullet-proof glass can be machined in addition to countless standard materials, such as hard stone, concrete or asphalt. Innovative products, such as ultra-thin and sound-insulated dry cutting saw blades, underline the continuous further development and optimisation of diamond products.

### TGD® Technology

TGD® (TYROLIT GRAIN DISTRIBUTION) is a unique technology developed by Tyrolit, which ensures consistently fast cutting rates, an extremely long lifetime and noticeable smooth running through optimised grain distribution. This provides for clean cuts that require no reworking. Furthermore, significantly less vibration is generated, resulting in less strain on the operator and the

machine. These advantages are particularly economically evident in continuous operation: The operator can distribute his effort evenly over the day and machines remain serviceable longer.



### Shapes



**C1SW**  
Dry cutting saw blade



**C3/C3W**  
Dry cutting saw blade



**C6W**  
Dry cutting saw blade



**UC3**  
Dry cutting saw blade



**C3R**  
Dry cutting saw blade



**C7SW**  
Dry cutting saw blade



## Application recommendation



Performance level	Specification	Pages	Universal	Concrete	Hard stone	Asphalt	Soft stone
<b>PREMIUM***</b>	DCU*** 4in1 TGD	326	•				
	DCU***	327	•				
	DCC***	327		•			
	DCH*** TGD	328			•		
	DCH***	328			•		
	DCA***	328				•	
	DCA+C*** 2in1	328			•	•	



Performance level	Specification	Pages	Universal	Concrete	Asphalt
<b>STANDARD**</b>	DCU**	330	•		
	DCU**-FC FASTCUT	330	•		
	DCC**	331		•	
	DCC** LL LONGLIFE	331		•	
	DCA**	332			•



Performance level	Specification	Pages	Universal	Concrete	Hard stone	Asphalt
<b>BASIC*</b>	DCU*	332	•			
	DCU*-FC	333	•			
	DCH*	333			•	
	DCA*	334				•
	DCA+C*	334			•	•

Items with grey lettering are only available on request.

# PREMIUM★★★ DRY CUTTING SAW BLADE DCU★★★ 4IN1-TGD

+ **Low cutting costs**  
because of high  
cutting speed

+ **Universal use**  
on concrete, hard stone,  
abrasive materials and steel



+ **Consistently fast cutting performance,**  
very long lifetime and no-  
ticeable smooth running with  
TGD® technology (Tyrolit Grain  
Distribution), a unique technol-  
ogy developed by Tyrolit for the  
optimised distribution of grain

+ **Reduced load for the user**  
as a result of unique smooth  
running



Materials able to be machined:  
Universal building materials, such as  
concrete, natural stone, clay brick,  
cellular concrete, etc. Details: the  
DCU\*\*\*4in1 dry cutting saw blade

impresses with excellent results when  
cutting concrete, hard stone, abrasive  
materials and steel.  
The possibility for universal use offers  
the user a product which is ready-

to-use at any time without a wheel  
change and ensures the successful  
completion of a project.

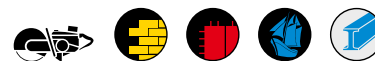
## PREMIUM★★★ DRY CUTTING SAW BLADE DCU\*\*\* 4in1 - TGD



	Shape	Type no.	Dimension	Segment height	Classification	
		C3W	736088	300x2.6x20	14	4in1
		22373	300x2.6x22.23	14	4in1	
		59580	300x2.6x25.4	14	4in1	
		736102	350x3.0x20	14	4in1	
		22377	350x3.0x25.4	14	4in1	
		59543	400x3.0x20	14	4in1	
		59545	400x3.0x25.4	14	4in1	

**PREMIUM\*\*\* DRY CUTTING SAW BLADE**  
DCU\*\*\*



Materials able to be machined: Universal building materials, such as concrete, clay brick, natural stone, etc. TYROLIT provides laser welded and directly sintered dry cutting saws that meet the highest quality and safety standards.  
With TYROLIT dry cutting saws, even plastics, fibreglass or bullet-proof

glass can be machined in addition to countless standard materials, such as hard stone, concrete or asphalt. Innovative products, such as ultra-thin and sound-insulated dry cutting saw blades, underline the continuous further development and optimisation of diamond products.

	Shape	Type no.	Dimension	Segment height	
		C6W	464545	300x2.6x20	12
		464546	300x2.6x22.23	12	
		464549	300x2.6x25.4	12	
		464551	350x3.0x20	12	
		464552	350x3.0x22.23	12	
		464553	350x3.0x25.4	12	
		464555	400x3.0x20	12	
		464556	400x3.0x25.4	12	

**PREMIUM\*\*\* DRY CUTTING SAW BLADE**  
DCC\*\*\*



Materials able to be machined: concrete, reinforced concrete, concrete products, hard materials, etc. TYROLIT provides laser welded and directly sintered dry cutting saws that meet the highest quality and safety standards.  
With TYROLIT dry cutting saws, even plastics, fibreglass or bullet-proof

glass can be machined in addition to countless standard materials, such as hard stone, concrete or asphalt. Innovative products, such as ultra-thin and sound-insulated dry cutting saw blades, underline the continuous further development and optimisation of diamond products.

	Shape	Type no.	Dimension	Segment height	
		C6W	465493	300x2.6x20	12
		465494	300x2.6x22.23	12	
		465495	300x2.6x25.4	12	
		465496	350x3.0x20	12	
		465498	350x3.0x22.23	12	
		465499	350x3.0x25.4	12	
		465501	400x3.0x20	12	

# PREMIUM★★★ DRY CUTTING SAW BLADE DCH★★★-TGD

+ **Low cutting costs**  
because of high  
cutting speed

+ **Reduced load for the user**  
as a result of unique smooth  
running



+ **Consistently fast cutting performance**, very long lifetime and noticeable smooth running with TGD® technology (Tyrolit Grain Distribution), a unique technology developed by Tyrolit for the optimised distribution of grain

+ **No reworking**  
due to very clean  
cutting edges



Details: the DCH\*\*\* dry cutting saw blade, specially developed using TGD® technology for hard stone, impresses with its cutting ability and smooth running. Reduced effort over

the entire lifetime allows for higher productivity. The perfectly optimised segments for the application create very clean, chip-free edges and ensure a flawless result.

Materials able to be machined: Concrete blocks, granite, gneiss, porphyry, paving slab, etc.

## PREMIUM★★★ DRY CUTTING SAW BLADE DCH\*\*\*-TGD



	Shape	Type no.	Dimension	Segment height	
		C3W	736095	300x2.6x20	14
			43485	300x2.6x25.4	14
			736105	350x3.0x20	14
			43490	350x3.0x25.4	14





**PREMIUM\*\*\* DRY CUTTING SAW BLADE**  
DCH\*\*\*

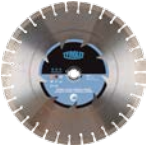

Materials able to be machined: Granite, gneiss, porphyry, paving slab, hard limestone, etc. TYROLIT provides laser welded and directly sintered dry cutting saws that meet the highest quality and safety standards. With TYROLIT dry cutting saws, even plastics, fibreglass or bullet-proof glass can be machined in addition to countless standard materials, such as

hard stone, concrete or asphalt. Innovative products, such as ultra-thin and sound-insulated dry cutting saw blades, underline the continuous further development and optimisation of diamond products.



	Shape	Type no.	Dimension	Segment height	
		C6W	464702	300x2.6x20	12
			464703	300x2.6x22.23	12
			464706	300x2.6x25.4	12
			464707	350x3.0x20	12
			464710	350x3.0x22.23	12
			464711	350x3.0x25.4	12
			464712	400x3.0x20	12

**PREMIUM\*\*\* DRY CUTTING SAW BLADE**  
DCA\*\*\*



Materials able to be machined: Asphalt, sandstone, extremely abrasive materials. Details: protective segments against the undercutting-effect. TYROLIT provides laser welded and directly sintered dry cutting saws that meet the highest quality and safety standards. With TYROLIT dry cutting saws, even plastics, fibreglass or bullet-proof

glass can be machined in addition to countless standard materials, such as hard stone, concrete or asphalt. Innovative products, such as ultra-thin and sound-insulated dry cutting saw blades, underline the continuous further development and optimisation of diamond products.



	Shape	Type no.	Dimension	Segment height	
		C7SW	465982	300x2.8x20	10
			465983	300x2.8x22.23	10
			465984	300x2.8x25.4	10
			465985	350x3.0x20	10
			465987	350x3.0x25.4	10

**PREMIUM\*\*\* DRY CUTTING SAW BLADE**  
DCA+C\*\*\*-2in1



Materials able to be machined: asphalt, green concrete with soft to hard material surcharges and a small amount of cured concrete. Details: protective segments against the undercutting-effect. TYROLIT provides laser welded and directly sintered dry cutting saws that meet the highest quality and safety standards.

With TYROLIT dry cutting saws, even plastics, fibreglass or bullet-proof glass can be machined in addition to countless standard materials, such as hard stone, concrete or asphalt. Innovative products, such as ultra-thin and sound-insulated dry cutting saw blades, underline the continuous further development and optimisation of diamond products.



	Shape	Type no.	Dimension	Segment height	Classification
		C73SW	465640	300x2.6.20	2in1
			465642	350x3.0x25.4	10

**STANDARD\*\* DRY CUTTING SAW BLADE**  
DCU\*\*



Materials able to be machined: Universal building materials, such as concrete, clay brick, natural stone, etc. TYROLIT provides laser welded and directly sintered dry cutting saws that meet the highest quality and safety standards.  
With TYROLIT dry cutting saws, even plastics, fibreglass or bullet-proof

glass can be machined in addition to countless standard materials, such as hard stone, concrete or asphalt. Innovative products, such as ultra-thin and sound-insulated dry cutting saw blades, underline the continuous further development and optimisation of diamond products.



	Shape	Type no.	Dimension	Segment height	
		C3W	464853	300x2.6x20	10
		464854	300x2.6x22.23	10	
		464855	300x2.6x25.4	10	
		464858	350x3.0x20	10	
		464859	350x3.0x25.4	10	
		465667	400x3.2x20	10	

**STANDARD\*\* DRY CUTTING SAW BLADE**  
DCU\*\*-FC



Materials able to be machined: Universal building materials, such as concrete, clay brick, natural stone, etc. TYROLIT provides laser welded and directly sintered dry cutting saws that meet the highest quality and safety standards.  
With TYROLIT dry cutting saws, even plastics, fibreglass or bullet-proof

glass can be machined in addition to countless standard materials, such as hard stone, concrete or asphalt. Innovative products, such as ultra-thin and sound-insulated dry cutting saw blades, underline the continuous further development and optimisation of diamond products.

	Shape	Type no.	Dimension	Segment height	Classification
		C3R	467433	300x3.0x20	10 FASTCUT
		467434	300x3.0x22.23	10 FASTCUT	
		467435	300x3.0x25.4	10 FASTCUT	
		467436	350x3.0x20	10 FASTCUT	
		467439	350x3.0x25.4	10 FASTCUT	



Diamond tools

**STANDARD\*\* DRY CUTTING SAW BLADE**  
DCC\*\*



Materials able to be machined: concrete, reinforced concrete, concrete products, hard materials, etc. TYROLIT provides laser welded and directly sintered dry cutting saws that meet the highest quality and safety standards.  
With TYROLIT dry cutting saws, even plastics, fibreglass or bullet-proof

glass can be machined in addition to countless standard materials, such as hard stone, concrete or asphalt. Innovative products, such as ultra-thin and sound-insulated dry cutting saw blades, underline the continuous further development and optimisation of diamond products.



	Shape		Type no.	Dimension	Segment height
		C3W	465503	300x2.6x20	10
			465505	300x2.6x22.23	10
			465507	300x2.6x25.4	10
			465509	350x3.0x20	10
			465662	350x3.0x22.23	10
			465512	350x3.0x25.4	10
			485041	400x3.0x20	10

**STANDARD\*\* DRY CUTTING SAW BLADE**  
DCC\*\*-LL



Materials able to be machined: concrete, reinforced concrete, concrete products, hard materials, etc. TYROLIT provides laser welded and directly sintered dry cutting saws that meet the highest quality and safety standards.  
With TYROLIT dry cutting saws, even plastics, fibreglass or bullet-proof

glass can be machined in addition to countless standard materials, such as hard stone, concrete or asphalt. Innovative products, such as ultra-thin and sound-insulated dry cutting saw blades, underline the continuous further development and optimisation of diamond products.

	Shape		Type no.	Dimension	Segment height	Classification
		C3W	484994	300x2.6x20	10	LONGLIFE
			484996	300x2.6x22.23	10	LONGLIFE
			484999	300x2.6x25.4	10	LONGLIFE
			485001	350x3.0x20	10	LONGLIFE
			485003	350x3.0x22.23	10	LONGLIFE
			485004	400x3.2x20	10	LONGLIFE

**STANDARD\*\* DRY CUTTING SAW BLADE**  
DCA\*\*



Materials able to be machined: Asphalt, sandstone, extremely abrasive materials. Details: protective segments against the undercutting-effect. TYROLIT provides laser welded and directly sintered dry cutting saws that meet the highest quality and safety standards. With TYROLIT dry cutting saws, even plastics, fibreglass or bullet-proof

glass can be machined in addition to countless standard materials, such as hard stone, concrete or asphalt. Innovative products, such as ultra-thin and sound-insulated dry cutting saw blades, underline the continuous further development and optimisation of diamond products.

	Shape	Type no.	Dimension	Segment height	
		C1SW	465519	300x2.8x20	10
		465520	350x3.0x20	10	
		465522	350x3.0x25.4	10	
		465525	400x3.2x25.4	10	
		465526	450x3.6x25.4	10	

**BASIC\* DRY CUTTING SAW BLADE**  
DCU\*



Materials able to be machined: Universal building materials, such as concrete, clay brick, natural stone, etc. Details: A 20-16 mm reduction bush is supplied with a disc diameter of 105 mm. TYROLIT provides laser welded and directly sintered dry cutting saws that meet the highest quality and safety standards.

With TYROLIT dry cutting saws, even plastics, fibreglass or bullet-proof glass can be machined in addition to countless standard materials, such as hard stone, concrete or asphalt. Innovative products, such as ultra-thin and sound-insulated dry cutting saw blades, underline the continuous further development and optimisation of diamond products.

	Shape	Type no.	Dimension	Segment height	
		C3W	466093	300x2.6x20	10
		466094	300x2.6x22.23	10	
		466095	300x2.6x25.4	10	
		466096	350x3.0x20	10	
		466098	350x3.0x22.23	10	
		466099	350x3.0x25.4	10	
		529399	400x3.2x25.4	10	
		529401	450x3.2x25.4	10	

Diamond tools





**BASIC★ DRY CUTTING SAW BLADE**  
DCU\*-FC



Materials able to be machined: Universal building materials, such as concrete, clay brick, natural stone, etc. Details: A 20-16 mm reduction bush is supplied with a disc diameter of 105 mm. TYROLIT provides laser welded and directly sintered dry cutting saws that meet the highest quality and safety standards.

With TYROLIT dry cutting saws, even plastics, fibreglass or bullet-proof glass can be machined in addition to countless standard materials, such as hard stone, concrete or asphalt. Innovative products, such as ultra-thin and sound-insulated dry cutting saw blades, underline the continuous further development and optimisation of diamond products.



	Shape	Type no.	Dimension	Segment height	Classification
		C3W 467280	300x3.0x20	10	FASTCUT
		467281	300x3.0x22.23	10	FASTCUT
		467282	300x3.0x25.4	10	FASTCUT
		467285	350x3.0x20	10	FASTCUT
		467288	350x3.0x22.23	10	FASTCUT
		467289	350x3.0x25.4	10	FASTCUT

**BASIC★ DRY CUTTING SAW BLADE**  
DCH\*



Materials able to be machined: Granite, porphyry, paving slab, hard limestone, etc. TYROLIT provides laser welded and directly sintered dry cutting saws that meet the highest quality and safety standards. With TYROLIT dry cutting saws, even plastics, fibreglass or bullet-proof glass can be machined in addition to countless standard materials, such

as hard stone, concrete or asphalt. Innovative products, such as ultra-thin and sound-insulated dry cutting saw blades, underline the continuous further development and optimisation of diamond products.



	Shape	Type no.	Dimension	Segment height
		C3W 467391	300x2.6x20	10
		467392	300x2.6x22.23	10
		467394	300x2.6x25.4	10
		467395	350x3.0x20	10
		467396	350x3.0x22.23	10
		467400	350x3.0x25.4	10

**BASIC★ DRY CUTTING SAW BLADE**  
DCA\*

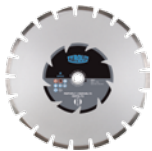

Materials able to be machined: Asphalt, sandstone, extremely abrasive materials. TYROLIT provides laser welded and directly sintered dry cutting saws that meet the highest quality and safety standards. With TYROLIT dry cutting saws, even plastics, fibreglass or bullet-proof glass can be machined in addition to countless standard materials, such

as hard stone, concrete or asphalt. Innovative products, such as ultra-thin and sound-insulated dry cutting saw blades, underline the continuous further development and optimisation of diamond products.



	Shape	Type no.	Dimension	Segment height	
		C1SW	465649	300x2.8x20	10
			465656	300x2.8x22.23	10
			465650	300x2.8x25.4	10
			465651	350x3.0x20	10
			465652	350x3.0x25.4	10
			529402	400x3.2x25.4	10
			529403	450x3.6x25.4	10

**BASIC★ DRY CUTTING SAW BLADE**  
DCA+C\* 2in1



Machines up to 15 kW | soft to medium-hard aggregates. Materials able to be machined: Green concrete, asphalt and a small amount of cured concrete. Details: all diameters are laser welded. With protective segments to guard against premature steel blade wear in the contact zone – (undercutting-effect). Also suitable for petrol cutting saws. Suitable for cutting

expansion joints, widening grooves and bevelling groove edges (groove depths of up to 15 cm). Tools for larger cutting depths are available on request. Large assortment of products ensures the optimum tool for varying construction site requirements in terms of concrete quality, maturity and choice of machine.

	Shape	Type no.	Dimension	Segment height	Classification	
		C1SW	736309	300x2.8x20	10	2in1
			736311	300x2.8x25.4	10	2in1
			736313	350x3.0x20	10	2in1
			80653	350x3.0x25.4	10	2in1

Diamond tools





**5.4 DIAMOND SAWS**  
FLOOR SAW





## DIAMOND SAW BLADES FOR FLOOR SAWS



Decades of experience in the production and application of floor saws and machines give TYROLIT the edge in the marketplace. As a result, our products can be seen as innovative solutions for large-scale projects while remaining cost-effective for everyday construction site use.



TYROLIT floor saw blades are designed to work perfectly with TYROLIT Hydrostress machines as well as all common floor saws.

- + Exceptional and consistent cutting performance coupled with a long service life
- + Universal use
- + Innovative diamond segment design
- + Quiet when working on reinforced concrete
- + Clean cutting edges
- + Large product range: diameters from 300 – 1200 mm in various segment widths



## Application recommendation

Performance level	Specification	Pages	  		
			Cured concrete	Asphalt	Green concrete
<b>PREMIUM***</b>	FSC***	338	●		
	FSA***	338		●	
	DCA+C*** 2in1	338		●	●

Performance level	Specification	Pages	  		
			Cured concrete	Asphalt	Green concrete
<b>BASIC★</b>	DCU*	339	●		
	DCA*	339		●	
	DCA+C* 2in1	339		●	●

Items with grey lettering are only available on request.

## Shapes



C1SW floor saw blade



C3W floor saw blade



C1S floor saw blade



C7W floor saw blade



C5 floor saw blade



C7SW floor saw blade



C73SW floor saw blade

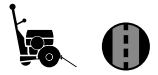

## PREMIUM★★★ FLOOR SAW BLADE | ASPHALT FSA\*\*\*



Machines up to 15 kW | soft to very hard aggregates. Details: laser welded up to a diameter of 600 mm. with protective segments to guard against premature steel blade wear in the contact zone – (undercutting-effect) and measuring bore for easy wear control of the segment height. A 35-25.4 mm reduction bush is supplied for saw blades with a 35 mm bore.

Suitable for repairing asphalt road surfaces, installation work (cables,

conduits, etc.) as well as removing damaged asphalt surfaces up to a thickness of 32 cm. The tools boast an extremely high cutting rate, long lifetime and a low cutting pressure to protect the machine.

	Shape	Type no.	Dimension	Segment height
		C7SW 574838	300x3.2x25.4	9
		574844	350x3.2x25.4	9
		574845	400x3.2x25.4	9
		574846	450x3.6x25.4	9
		574848	500x3.6x25.4	9
		574850	600x3.6x25.4	9

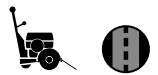

## PREMIUM★★★ FLOOR SAW BLADE | CURED CONCRETE FSC\*\*\*



Machines up to 15 kW | soft to medium-hard aggregates. Details: Laser welded up to a diameter of 600 mm. Equipped with measuring bore for easy wear control of the segment height. A 35-25.4 mm reduction bush is supplied for saw blades with a 35 mm bore.

Suitable for repairing, dismantling and demolishing roads and factory

buildings. Can also be used to remove damaged concrete slabs and to break through stonework up to 32 cm thick. The tools boast an extremely high cutting rate, long lifetime and a low cutting pressure to protect the machine.

	Shape	Type no.	Dimension	Segment height
		C7W 574853	300x3.2x25.4	12
		574854	350x3.2x25.4	12
		574855	400x3.2x25.4	12
		574856	450x3.6x25.4	12
		574857	500x3.6x25.4	12
		574858	600x3.6x25.4	12



## PREMIUM★★★ FLOOR SAW BLADE | GREEN CONCRETE DCA+C\*\*\* -2in1



Machines up to 15 kW | soft to medium-hard aggregates. Materials able to be machined: Green concrete, asphalt and a small amount of cured concrete. Details: all diameters are laser welded. With protective segments to guard against premature steel blade wear in the contact zone – (undercutting-effect). Also suitable for petrol cutting saws.

Suitable for cutting expansion joints, widening grooves and bevelling

groove edges (groove depths of up to 15 cm). Tools for larger cutting depths are available on request. Large assortment of products ensures the optimum tool for varying construction site requirements in terms of concrete quality, maturity and choice of machine. The tools boast an extremely high cutting rate, very long lifetime and a low cutting pressure to protect the machine.

	Shape	Type no.	Dimension	Segment height
		C73SW 465640	300x2.6x20	10
		465642	350x3.0x25.4	10

**BASIC★ FLOOR SAW BLADE | GREEN CONCRETE**  
DCA+C\* 2in1



Machines up to 15 kW | soft to medium-hard aggregates. Materials able to be machined: Green concrete, asphalt and a small amount of cured concrete. Details: all diameters are laser welded. With protective segments to guard against premature steel blade wear in the contact zone – (undercutting-effect). Also suitable for petrol cutting saws. Suitable for cutting

expansion joints, widening grooves and bevelling groove edges (groove depths of up to 15 cm). Tools for larger cutting depths are available on request. Large assortment of products ensures the optimum tool for varying construction site requirements in terms of concrete quality, maturity and choice of machine.

	Shape	Type no.	Dimension	Segment height	Classification
		C1SW 736309	300x2.8x20	10	2in1
		736311	300x2.8x25.4	10	2in1
		736313	350x3.0x20	10	2in1
		80653	350x3.0x25.4	10	2in1

**BASIC★ FLOOR SAW BLADE | ASPHALT**  
DCA\*

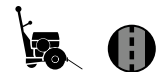

Machines up to 15 kW | soft to medium-hard aggregates. Details: All tools are laser welded. With protective segments to guard against premature steel blade wear in the contact zone – (undercutting-effect). Also suitable for petrol cutting saws.

Suitable for repairing asphalt road surfaces, installation work (cables, conduits, etc.) as well as removing damaged asphalt surfaces up to a thickness of 16 cm. The tools boast a high cutting rate and long lifetime.

	Shape	Type no.	Dimension	Segment height
		C1SW 465650	300x2.8x25.4	10
		465652	350x3.0x25.4	10
		529402	400x3.2x25.4	10
		529403	450x3.6x25.4	10

**BASIC★ FLOOR SAW BLADE | CURED CONCRETE**  
DCU\*

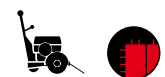

Machines up to 15 kW | soft to medium-hard aggregates. Details: All tools are laser welded. Also suitable for petrol cutting saws. Suitable for repairing, dismantling and demolishing roads and factory buildings. Can also be used to remove damaged concrete slabs and to

break through stonework up to 16 cm thick. The tools boast a high cutting rate and long lifetime

	Shape	Type no.	Dimension	Segment height
		C3W 466095	300x2.6x25.4	10
		466099	350x3.0x25.4	10
		529399	400x3.2x25.4	10
		529401	450x3.6x25.4	10









**5.5 DIAMOND SAWS**  
TABLE SAWS





## DIAMOND SAW BLADES FOR TABLE SAWS

TYROLIT table saw blades impress with an excellent cutting performance and a long lifetime. They are optimised for the relevant material or application.

TYROLIT table saw blades are developed to work perfectly with TYROLIT Hydrostress machines and therefore meet all cutting work challenges and deliver the best results.

## Application recommendation



Performance level	Specification	Pages	Universal	Hard stone	Engineering bricks	Abrasive materials	Soft stone	Tiles
<b>PREMIUM★★★</b>	EB-T***	344	•					
	EH-T***	345		•				
	TSS10***	346			•			
	F40***	345				•		
	ES-T***	344					•	
	DCT***	345						•



Performance level	Specification	Pages	Universal
<b>STANDARD★★</b>	XB-T**	2in1 346	•

Items with grey lettering are only available on request.

## Shapes



C1W table saw blade



C2W table saw blade



C1 table saw blade



C2 table saw blade



C5 table saw blade



1A1R table saw blade

### PREMIUM\*\*\* TABLE SAW BLADE EB-T\*\*\*



Materials able to be machined: cellular concrete, sand-lime brick, pumice stone, clay brick, etc. Details: 35-30 mm and 30-25.4 mm reduction bushes are included with disc diameters up to 900 mm. A 60-55 mm reduction bush is supplied with disc diameters of 900 mm and upwards. TYROLIT table saw blades impress with an excellent cutting performance

and a long lifetime. TYROLIT table saw blades are developed to work perfectly with TYROLIT Hydrostress machines and therefore meet all cutting work challenges and deliver the best results.

	Shape	Type no.	Dimension	Segment height
		C2W 5692	250x2.2x35	7
		5693	300x2.4x35	7
		5696	350x2.8x35	7
		5707	400x3.2x35	7
		C1W 5708	500x3.6x35	7
		5715	600x3.6x35	7
		5720	625x3.6x35	7
		C5 5721	650x3.9x35	7
		C1 5723	900x4.7x60	7
		175115	1000x4.7x60	7

### PREMIUM\*\*\* TABLE SAW BLADE ES-T\*\*\*



Materials able to be machined: soft stone, such as marble and sand-lime brick. Details: 35-30 mm and 30-25.4 mm reduction bushes are supplied. TYROLIT table saw blades impress with an excellent cutting performance and a long lifetime.

TYROLIT table saw blades are developed to work perfectly with TYROLIT Hydrostress machines and therefore meet all cutting work challenges and deliver the best results.

	Shape	Type no.	Dimension	Segment height
		C2 5684	300x2.4x35	7
		5685	350x2.8x35	7





### PREMIUM\*\*\* TABLE SAW BLADE DCT\*\*\*



Materials able to be machined: ceramic tiles, fine stoneware, porcelain, terrazzo slabs. Details: ultra-thin saw blades with excellent properties. 35-30 mm and 30-25.4 mm reduction bushes are supplied. TYROLIT table saw blades impress with an excellent cutting performance

and a long lifetime. TYROLIT table saw blades are developed to work perfectly with TYROLIT Hydrostress machines and therefore meet all cutting work challenges and deliver the best results.



	Shape	Type no.	Dimension	Segment height	
		1A1R	639566	180x1.4x35	10
			701934	200x1.6x35	10
			639568	230x1.6x35	10
			639569	250x1.6x35	10
			639570	300x2.0x35	10
			639571	350x2.0x35	10

### PREMIUM\*\*\* TABLE SAW BLADE EH-T\*\*\*



Materials able to be machined: granite, gneiss, hard sand-lime brick, hard clay brick. Details: 35-30 mm and 30-25.4 mm reduction bushes are supplied. TYROLIT table saw blades impress with an excellent cutting performance

and a long lifetime. TYROLIT table saw blades are developed to work perfectly with TYROLIT Hydrostress machines and therefore meet all cutting work challenges and deliver the best results.

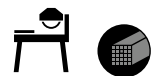

	Shape	Type no.	Dimension	Segment height	
		C2W	5687	250x2.2x35	7
			5688	300x2.6x35	7
			5689	350x2.8x35	7

### PREMIUM\*\*\* TABLE SAW BLADE F40\*\*\*



Materials able to be machined: type F40 is designed primarily for refractory cutting. TYROLIT table saw blades impress with an excellent cutting performance and a long lifetime.

TYROLIT table saw blades are developed to work perfectly with TYROLIT Hydrostress machines and therefore meet all cutting work challenges and deliver the best results.

	Shape	Type no.	Dimension	Segment height	
		C2W	817606	300x2.4x25.4	7
			817603	350x2.8x25.4	7
			817607	400x3.2x25.4	7
			547136	500x3.6x25.4	7



### PREMIUM\*\*\* TABLE SAW BLADE

TSS10\*\*\*



Materials able to be machined: type TSS10 has been specially designed for the machining of engineering bricks (e.g. Stradalit). Details: 35-30 mm and 30-25.4 mm reduction bushes are supplied. TYROLIT table saw blades impress with an excellent cutting performance and a long lifetime. TYROLIT table saw blades are developed to work perfectly with TYROLIT

Hydrostress machines and therefore meet all cutting work challenges and deliver the best results.

	Shape	Type no.	Dimension	Segment height
		C1 894258	350x2.8x35	9







### STANDARD\*\* TABLE SAW BLADE

XB-T\*\*



Materials able to be machined: cellular concrete, sand-lime brick, pumice stone, clay brick, etc. Details: 35-30 mm and 30-25.4 mm reduction bushes are included with diameters up to 600 mm. A 60-55 mm reduction bush is supplied with diameters of 625 mm and upwards. TYROLIT table saw blades impress with an excellent cutting performance

and a long lifetime. TYROLIT table saw blades are developed to work perfectly with TYROLIT Hydrostress machines and therefore meet all cutting work challenges and deliver the best results.

	Shape	Type no.	Dimension	Segment height	Classification
		C2W 284967	250x2.2x35	7	
		284968	300x2.4x35	7	
		284969	350x2.8x35	7	
		284970	400x3.2x35	7	
		C1W 462504	500x3.2x35	9	
		462506	600x3.6x35	9	
		355613	625x3.6x60	9	
		C1 355631	650x3.9x60	9	
		355633	700x3.9x60	9	
		338399	900x4.8x60	9	
		C5 437376	1000x4.8x60	9	
		C2GW 188495	350x2.8.35	7	SILENT
	C1GW 203258	700x3.9x60	7	SILENT	

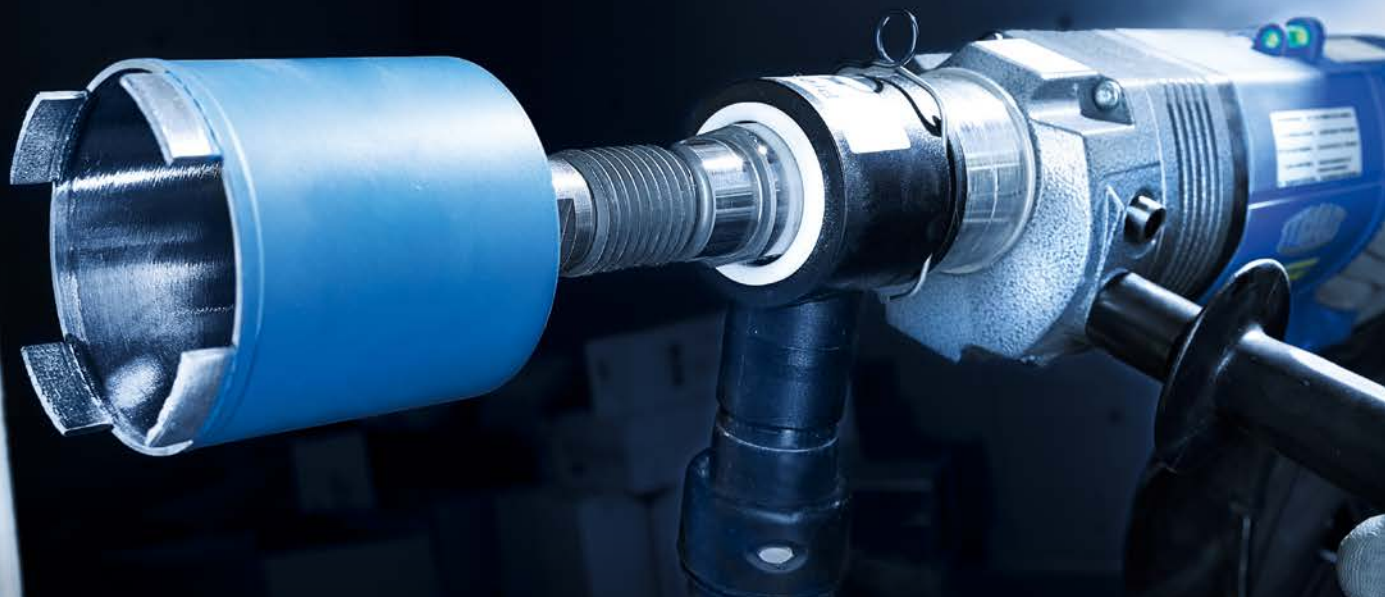

## **5.6 DRY DRILL BITS**

### **CORE DRILLING**



## DRILL BITS FOR DRY DRILLING

TYROLIT dry drill bits combine with the TYROLIT DME18SD 1.8 kW drill motor to create a perfect dry drilling system.

Openings in the lid allow the connection of an industrial suction unit for 100% dust extraction, thus saving on time-intensive reworking.



## Selecting the right dry drill bit

DIAMETER	≤ 82 mm	≥ 91 mm
SPEED	2,000-3,000 rpm	1,000-1,500 rpm
Plasterboard Cellular concrete Plastic tubes (PVC, PP, PE) Soft fire-resistant bricks Sandstone, porous natural stone Tiles Roof tiles Clinker Fine stoneware	Without hammer operation	
Soft sand-lime brick Clay brick Lightweight concrete slabs Woodchip-concrete blocks and slabs Fireclay bricks	Hammer operation recommended (no drill hammer)	
Concrete block Hard sand-lime brick Terrazzo Concrete Lightly reinforced concrete	Hammer operation required (no drill hammer)	

**PREMIUM\*\*\* DRY DRILL BITS**  
DDL\*\*\*



The newly developed premium dry drill bit impresses in all manner of ways. The patented manufacturing process with segments of just 3 mm wide not only achieves a dramatic reduction in weight for significantly shorter drilling times, but also reduces the pressure and formation of dust. TYROLIT dry drill bits combine with the TYROLIT DME18SD\*\*\* 1.8 kW drill

motor to create the perfect dry drilling system. Openings in the lid allow the connection of an industrial suction unit for 100% dust extraction, thus saving on time-intensive reworking.

	Type no.	Dimension	Segment height
	HOLT 597949	67x70xM16	9
	597950	81x70xM16	9
	479949	51x150xM16	9
	532197	55x150xM16	9
	499798	61x150xM16	9
	499802	67x150xM16	9
	532198	71x150xM16	9
	475894	81x150xM16	9
	532200	91x150xM16	9
	499803	101x150xM16	9
	532201	106x150xM16	9
	532202	111x150xM16	9
	532204	116x150xM16	9
	532205	121x150xM16	9
	499804	126x150xM16	9
	532206	131x150xM16	9
	532207	141x150xM16	9
532208	151x150xM16	9	

**STANDARD\*\* DRY DRILL BITS**  
DDL\*\*



Quality tool for daily use, impressive performance and lifetime. TYROLIT dry drill bits combine with the TYROLIT DME18SD\*\*\* 1.8 kW drill motor to create the perfect dry drilling system. Openings in the lid allow

the connection of an industrial suction unit for 100% dust extraction, thus saving on time-intensive reworking.

	Type no.	Dimension	Segment height
	HOLT	899272	32x150xM16
		899271	42x150xM16
		252911	52x150xM16
		252912	56x150xM16
		252913	62x150xM16
		252914	68x150xM16
		252915	72x150xM16
		252916	82x150xM16
		252917	92x150xM16
		252918	102x150xM16
		252919	107x150xM16
		252920	117x150xM16
		252921	127x150xM16
		252923	162x150xM16
252924	200x150xM16		

**BASIC\* DRY DRILL BITS**  
DDL\*



Perfect tool for installing sockets and junction boxes as well as smaller breakthrough jobs. TYROLIT dry drill bits combine with the TYROLIT DME18SD\*\*\* 1.8 kW drill motor to create the perfect dry drilling system. Openings in the lid allow

the connection of an industrial suction unit for 100% dust extraction, thus saving on time-intensive reworking.







	Type no.	Dimension	Segment height
	HOLT	650292	68x70xM16
		650293	82x70xM16

**ACCESSORIES DRY DRILL BITS**

Connections for all common machines



Adapter suitable for all commercial machines - with and without soft impact drill bit connection: M16. Accessories for TYROLIT PREMIUM\*\*\* and BASIC\* dry drill bits guarantee optimum results on all commercial machines – with and without soft impact.

	Type no.	Connection to machine	Pilot drills / centring spikes
	850026	5/8"	SDS pilot drill
	850011	HEX SW12	SDS pilot drill
	116264	HEX SW12	Cone pilot drill
	707827	HEX SW12	Centring spike 120/233 mm
	707831	SDS	Centring spike 120/233 mm
	707834	M18 x 2.5	Centring spike 120/233 mm
	707824	5/8"	Centring spike 120/233 mm





**ACCESSORIES DRY DRILL BITS**

Compact universal dust extraction system



Dust extraction adapter compatible with all drilling diameters. Accessories for TYROLIT PREMIUM\*\*\* and BASIC\* dry drill bits guarantee optimum results on all commercial machines – with and without soft impact.

	Type no.	Designation	Product info
	10983845	Centering spike 120 mm	BASIC* drill PREMIUM*** NL 70 mm drill
	10986189	Centering spike 233 mm	NL 150 mm drill
	10986190	Strap wrench	For releasing the drill bit from the dust extraction adaptor
	10983964	Dust extraction adapter with M16 connection	For connecting to an industrial vacuum cleaner

**ACCESSORIES DRY DRILL BITS**

Centring aids



Pilot drill with SDS connection or cone facilitates the precise positioning of the drill bits and enables exact results. When using a centring shaft, openings can also be made in 30 cm thick walls using 150 mm drill bits. Accessories for TYROLIT PREMIUM\*\*\* and BASIC\* dry drill bits guarantee optimum results on all commercial machines – with and without soft impact.

	Type no.	Designation	Product info
	579420	Pilot drill SDS 160 mm	NL 60/70 mm drill
	579424	Pilot drill SDS 260 mm	NL 150 mm drill
	116263	Pilot drill A-taper 160 mm only for adaptor 116254	NL 60/70 mm drill
	579503	Centering shaft SDS 250 mm	NL 150 mm drill

**PREMIUM\*\*\* TILE DRILLS**  
DDT\*\*\*



TYROLIT vacuum brazed diamond coring bit for all ceramic tiles, fine stoneware and marble slabs. Maximum drilling comfort, suitable for universal use with M14 connection for angle grinders, and adapter for drilling machines. Suitable for dry and wet drilling. Perfect, chip-free drilling in tiled and sanitary areas.

	Type no.	Diameter	Length	Mounting	Segment height
	HOLT 69833	6	45	HEX	4
	69848	8	45	HEX	4
	69855	10	45	HEX	4
	69856	12	45	HEX	4
	69860	14	45	HEX	4
	69769	20	45	M14	4
	69768	38	45	M14	4
	69767	52	45	M14	4
	69766	65	45	M14	4
	51392	75	45	M14	4

**PREMIUM\*\*\* TILE DRILL-SET**  
DDT\*\*\*



The TYROLIT tile drill-set consists of universally applicable, vacuum-brazed diamond core bites for vacuum-brazed tile drill-set for universal use and maximum drilling comfort. The drills are equipped with with M14 connector for angle grinders as well as adaptors for drill motors. Our products are suitable for dry and wet drilling and always deliver perfect, chip-free drilling holes in tiles and sanitary ware.

For easy use and mounting the set contains different adaptors, an allen key as well as a pilot drill for exact and accurate work.

Type no.	Contents
51470	ø 20, 38, 52, 65, 75 mm M14/HEX adapter M14/SDS adapter Allen key 6x110 pilot drill A/F 19 wrench



Diamond tools



## 5.7 WET DRILL BITS CORE DRILLING





## DRILL BITS FOR WET DRILLING

Decades of experience in the production and application of core drill bits and drilling machines give TYROLIT the edge in the marketplace.

As a result, our products can be viewed as innovative solutions for large-scale projects while remaining cost-effective for everyday construction site use. Especially suitable for drilling reinforced or normal concrete. Can be operated on a drill rig or hand-held.

TYROLIT core drill bits are designed to work perfectly with TYROLIT Hydrostress machines.



## Speeds

DIAMETER	SPEED	Drive power
Concrete (2-3 m/s)		
mm	rpm	kW
18	2,100-3,200	1
32	1,200-1,800	
42	900-1,400	2
52	750-1,100	
62	620-950	3
72	550-800	
82	470-700	4
102	370-550	
122	310-470	3
152	250-380	
162	240-350	4
182	210-320	
202	190-280	3
250	150-230	
300	130-190	4
400	100-140	
500	80-120	4

## Information/ Recommendations

- + Highest levels of performance at peripheral speeds of 2-3 m/s on concrete (1.2-1.8 m/s on reinforced concrete, 3.2-3.8 m/s on very abrasive materials).
- + Above drill diameters of 450 mm, large diameter flange (GR-F) is recommended as drill adaptor. Drill range with GR-F adaptor on request.
- + The correct drill rig mounting is essential.
- + The correct coolant quantity is also important for the optimum drilling performance ("milky" consistency of the water).
- + The machine application and safety information must be read and understood before starting work. The drilling safety manual will be sent to you on request.

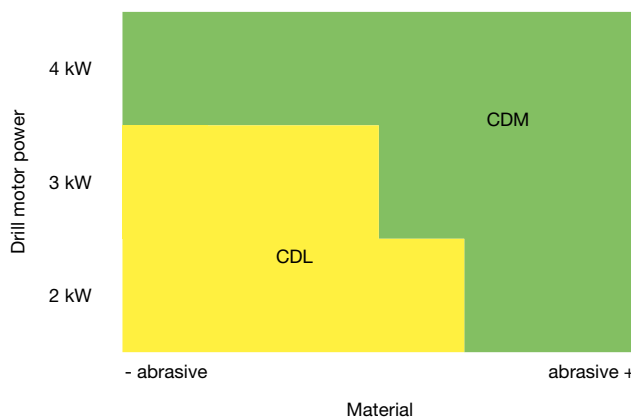

## Service

- + Products for concrete (asphalt, masonry, steel and special applications on request).
- + Mountings and connection threads available to comply with local standards and tailored to suit all types of motors (electric, hydraulic).
- + Perfect system solution in conjunction with TYROLIT Hydrostress drill motors and drill rigs.
- + Extensive range of accessories available.
- + Special dimensions and individual solutions available on request.
- + We will be pleased to provide technical support and system solutions for special construction sites.

## STANDARD\*\* WET DRILLING BITS CDL\*\*



Drill motors up to 3 kW | soft to medium-hard concrete aggregates. Details: quality tools for everyday use. An impressive drilling speed-lifetime ratio. Universal use, lasting quality. Laser welded segments up to a diameter of 250 mm for maximum safety.

Decades of experience in the production and application of core drill bits and drilling machines give TYROLIT the edge in the marketplace.

As a result our products can be viewed as innovative solutions for large-

scale projects while remaining cost-effective for everyday construction site use. Especially suited to drilling reinforced or normal concrete. Can be operated on drill rigs or off-hand. TYROLIT core drill bits are developed to work perfectly with TYROLIT Hydrostress machines.

	Type no.	Diameter	Length	Segment height	Connection	
	HOHL3	475019	32	400	7	R1/2"
		475024	42	450	7	R1/2"
	HOHL1D	466842	52	450	8.5	11/4"
		466843	62	450	8.5	11/4"
		466844	72	450	8.5	11/4"
		466845	82	450	8.5	11/4"
		466846	92	450	8.5	11/4"
		466847	102	450	8.5	11/4"
		466848	107	450	8.5	11/4"
		466849	112	450	8.5	11/4"
		466850	122	450	8.5	11/4"
		466852	127	450	8.5	11/4"
		466853	132	450	8.5	11/4"
		500056	142	450	8.5	11/4"
		466854	152	450	8.5	11/4"
		466855	162	450	8.5	11/4"
		466856	182	450	8.5	11/4"
		466857	202	450	8.5	11/4"
466858	250	450	8.5	11/4"		

## STANDARD★★ WET DRILLING BITS

CDM\*\*



Drill motors over 3 kW | medium-hard to hard concrete aggregates. Details: quality tools for everyday use. an impressive drilling speed-lifetime ratio. Universal use, lasting quality. Laser welded segments up to a diameter of 250 mm for maximum safety.

Decades of experience in the production and application of core drill bits and drilling machines give TYROLIT the edge in the marketplace.

As a result our products can be viewed as innovative solutions for large-

scale projects while remaining cost-effective for everyday construction site use. Especially suited to drilling reinforced or normal concrete. Can be operated on drill rigs or off-hand. TYROLIT core drill bits are developed to work perfectly with TYROLIT Hydrostress machines.



	Type no.	Diameter	Length	Segment height	Connection
HOHL1D	466887	52	450	8.5	1 1/4"
	476408	52	450	8.5	PIXIE
	466888	62	450	8.5	1 1/4"
	466889	72	450	8.5	1 1/4"
	500259	77	450	8.5	1 1/4"
	466890	82	450	8.5	1 1/4"
	476438	82	450	8.5	PIXIE
	466891	92	450	8.5	1 1/4"
	466892	102	450	8.5	1 1/4"
	476440	102	450	8.5	PIXIE
	466893	107	450	8.5	1 1/4"
	466894	112	450	8.5	1 1/4"
	476442	112	450	8.5	PIXIE
	466895	122	450	8.5	1 1/4"
	466896	127	450	8.5	1 1/4"
	466898	132	450	8.5	1 1/4"
	500268	142	450	8.5	1 1/4"
	546639	142	450	8.5	PIXIE
	466899	152	450	8.5	1 1/4"
	476449	152	450	8.5	PIXIE
	466900	162	450	8.5	1 1/4"
	476450	162	450	8.5	PIXIE
	466902	182	450	8.5	1 1/4"
	466903	202	450	8.5	1 1/4"
	476452	202	450	8.5	PIXIE
	500289	225	450	8.5	1 1/4"
	544172	225	450	8.5	PIXIE
	466904	250	450	8.5	1 1/4"
	476453	250	450	8.5	PIXIE

## STANDARD\*\* WET DRILLING BITS

### CDM\*\* thin-walled



Medium-hard to hard concrete aggregates. Details: quality tools for everyday use. an impressive drilling speed-lifetime ratio. Universal use, lasting quality. 2.0 mm segment width up to a diameter of 121 mm and 2.5 mm segment width from a diameter of 131 mm upwards.

Decades of experience in the production and application of core drill bits and drilling machines give TYROLIT the edge in the marketplace.

As a result our products can be viewed as innovative solutions for large-

scale projects while remaining cost-effective for everyday construction site use. Especially suited to drilling reinforced or normal concrete. Can be operated on drill rigs or off-hand. TYROLIT core drill bits are developed to work perfectly with TYROLIT Hydrostress machines.

	Type no.	Diameter	Length	Segment height	Connection	
	HOHL2	495674	36	350	7	R1/2"
		495817	41	350	7	R1/2"
		495818	51	350	7	R1/2"
		495820	61	350	7	R1/2"
		495824	71	350	7	R1/2"
		495826	81	350	7	R1/2"
		495830	91	350	7	R1/2"
		495832	101	400	7	R1/2"
		495833	111	400	7	R1/2"
		495834	121	400	7	R1/2"
		495836	131	400	7	R1/2"
		495837	141	400	7	R1/2"
		495838	151	400	7	R1/2"
		495841	161	400	7	R1/2"
		495842	171	400	7	R1/2"
		495843	181	400	7	R1/2"
	495844	191	400	7	R1/2"	
	495845	201	400	7	R1/2"	

## ACCESSORIES WET DRILLING BITS

### Adapter



Decades of experience in the production and application of core drill bits and drilling machines give TYROLIT the edge in the marketplace. As a result our products can be viewed as innovative solutions for large-scale projects while remaining cost-effective for everyday construction site use.

Especially suited to drilling reinforced or normal concrete. Can be operated on drill rigs or off-hand. TYROLIT core drill bits are developed to work perfectly with TYROLIT Hydrostress machines.

	Type no.	Connection 1	Connection 2	
	ADAPT	374035	1 1/4" F	R1/2" F
		381983	R1/2" M	1 1/4" M
		462700	HT 1.5 F	1 1/4" M
		681095	HT 2 F	1 1/4" M
		759007	R1/2" M	10
		909220	1 1/4" F	3-LOCH



**ACCESSORIES WET DRILLING BITS**

## Sharpening plates



Decades of experience in the production and application of core drill bits and drilling machines give TYROLIT the edge in the marketplace. As a result our products can be viewed as innovative solutions for large-scale projects while remaining cost-effective for everyday construction site use.

Especially suited to drilling reinforced or normal concrete. Can be operated on drill rigs or off-hand. TYROLIT core drill bits are developed to work perfectly with TYROLIT Hydrostress machines.

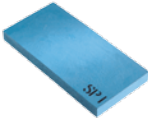
	Type no.	Length	Height	Width
	SP1 497322	55	25	320
	484627	160	30	320
	484672	320	55	320

**ACCESSORIES WET DRILLING BITS**

## Brazing magnets



Decades of experience in the production and application of core drill bits and drilling machines give TYROLIT the edge in the marketplace. As a result our products can be viewed as innovative solutions for large-scale projects while remaining cost-effective for everyday construction site use.

Especially suited to drilling reinforced or normal concrete. Can be operated on drill rigs or off-hand. TYROLIT core drill bits are developed to work perfectly with TYROLIT Hydrostress machines.

	Type no.	Length	Protrusion 1	Protrusion 2
	HMAG 529455	56	0.75	1
	529456	56	0.5	1.25

**ACCESSORIES WET DRILLING BITS**

## Extensions



Decades of experience in the production and application of core drill bits and drilling machines give TYROLIT the edge in the marketplace. As a result our products can be viewed as innovative solutions for large-scale projects while remaining cost-effective for everyday construction site use.

Especially suited to drilling reinforced or normal concrete. Can be operated on drill rigs or off-hand. TYROLIT core drill bits are developed to work perfectly with TYROLIT Hydrostress machines.

	Type no.	Length	Connection
	HVERL 400439	100	R1/2"
	378198	100	1 1/4"
	359475	200	R1/2"
	359471	200	1 1/4"
	359476	300	R1/2"
	359472	300	1 1/4"
	889232	400	R1/2"
	359473	400	1 1/4"
	707230	500	R1/2"
	359474	500	1 1/4"

**ACCESSORIES WET DRILLING BITS**

## Water liners



Decades of experience in the production and application of core drill bits and drilling machines give TYROLIT the edge in the marketplace. As a result our products can be viewed as innovative solutions for large-scale projects while remaining cost-effective for everyday construction site use.

Especially suited to drilling reinforced or normal concrete. Can be operated on drill rigs or off-hand. TYROLIT core drill bits are developed to work perfectly with TYROLIT Hydrostress machines.

	Type no.	Connection
	WSPB 478074	SW12
	122567	1 1/4"
	122569	R1/2"



Diamant-  
werkzeuge









## **5.8 TYROLIT MACHINES OVERVIEW**



## **TILE SAW TTE250★★★**

### **CUTTING DEPTH UP TO 60 mm**

Large cutting lengths from a short total saw length

Clean cut thanks to precise saw table guidance. Practical handling and easy to transport due to compact design and lightweight construction. Exceptionally easy to clean due to detachable water tank made from robust, high quality plastic. Maximum safety due to centrally located emergency stop switch. Highly flexible with a range of adjustment and application options.



## **MASONRY SAW TBE350★★**

### **CUTTING DEPTH UP TO 110 mm**

Uncompromising price-performance ratio

Clean cut thanks to sturdy saw table with anti-slip support. Mitre cutting made extremely easy with swivelling saw head. Permanent tool cooling and reduction of servicing requirements to a minimum due to anti-contamination positioning of water pump. Easy to transport thanks to detachable table feet. Maximum safety due to centrally located emergency stop switch. Highly flexible with a range of adjustment and application options.



---

## **DRILL MOTOR DME22SU★★**

### CORE DRILLING UP TO Ø 180 mm

Ideal for electrical and installation work

Easy handling due to adjustable side handle and soft start. Optimum speeds thanks to three-speed transmission and variable speed setting. Safe working due to integrated overload cut-outs and PRCD safety switch. Dry drilling is possible with the included M16 adapter.



---

## **DRILL RIG DRA150★★**

### CORE DRILLING UP TO Ø 150 mm

Ideal for electrical and installation work

Suitable for 550 mm long drill bits. 90°-45° diagonal adjustment with angle indicator. Easy handling due to centre indicator, spirit levels and carrying handle. Secure attachment by means of dowel foot.



## CORE DRILLING SYSTEM DRS160★★

### CORE DRILLING UP TO Ø 160 mm

#### The ideal core drill entry model

Optimally matched system solution consisting of drill motor and drill rig. Easiest handling using preset speed and compact lightweight construction. Controlled working and overloading prevention thanks to LED-based electronic load indicator. Maximum safety due to integrated PRCD safety switch.



## CORE DRILLING SYSTEM DRU160★★★

### CORE DRILLING UP TO Ø 160 mm

#### The lightweight among drill rigs up to Ø 160 mm

Precise drilling thanks to optimised support with sturdy roller guide. Quick mounting of common drill motors with standardised clamping collar system. Time-saving drill rig set-up by means of centre indicator, angle indicator and spirit level. Convenient operation via user-friendly hand crank. Maximum flexibility thanks to dowel or vacuum attachment facility. Simplified adjustment tasks and utilisation of the entire drill bit length due to intelligent system design.





## CORE DRILLING SYSTEM DRA250★★★ DRU250★★★ CORE DRILLING UP TO Ø 250 mm

Impressive stability and drilling performance through sturdy processing and robust drilling columns with wide gear teeth

Precise drilling thanks to optimised support with sturdy roller guide. Easy transport along with simple assembly and disassembly due to compact lightweight construction. Quick and safe drill motor mounting using proven ModulDrill quick change clamping system. Convenient operation using two speed feed gearbox and user-friendly hand crank. Easy diagonal drilling using integrated angle indicator. Maximum flexibility thanks to dowel or vacuum attachment facility.



## FLOOR SAW FSG513 CUTTING DEPTH UP TO 170 MM

Excellent cutting behaviour through intelligent weight distribution.

Easy handling due to ergonomically arranged control panel. High resilience and vibration reduction thanks to extremely robust, high quality chassis. Increased flexibility with left and right cutting function and corner cutting function. Safe and easy to transport using balanced transport hook. Optimum tool cooling is provided via the proven water supply system. Service-friendly machine design. Reliable Honda petrol engine with cyclone air filter. Precise cutting using standard cut indicator. Maximum safety due to centrally located emergency stop switch and integrated brake.





9118-11  
III 1959-59C

9118-11  
III 1959-59C

9118-11  
III 1959-59C

9118-11  
III 1959-59C

1735

9118-11  
III 1959-59C

9118-11  
III 1959-59C

HYMO

DEMAG

DEMAG 200g

9118-11  
III 1959-59C

9118-11  
III 1959-59C



# NOTES

<b>Safety</b>	<b>372</b>
SAFETY BRAND TYROLIT	372
TYROLIT QUALITY MANAGEMENT SYSTEM	372
Final inspection - checks at TYROLIT	372
Safety	373
Storage of grinding wheels	373
Checking of grinding wheels on delivery	373
Checking of grinding wheels prior to mounting	374
Clamping methods for grinding wheels	374
Test run prior to start-up	376
Eye protection and protective clothing	376
Summary	376
Safety information	376
Dos & don'ts	377
Table of recommended speeds	378
<b>Quick product search</b>	<b>379</b>
Keyword index	380
Product finder	382
Index	389
<b>General</b>	<b>431</b>
TYROLIT addresses	432
Legal notice	436

# SAFETY

## SafetyBrand TYROLIT

Our aim was and is to make our products even safer for our users:

Through our work as the founder member of the “Organisation for the Safety of Abrasives (oS<sup>a</sup>)”, through close cooperation with the safety authorities and through practical communication with our users all over the world.

### aim of oSa<sup>®</sup>

The main aim of oSa<sup>®</sup> is defined in terms of absolute protection for the users of grinding tools, whereby members undertake to provide a consistently high level of quality, adopt a rigorous approach towards quality assurance and strive to develop new, improved standards of safety.



## TYROLIT Quality Management System

The TYROLIT quality management system has been certified to ISO 9001:2000 by an external authorised body for the entire production area. Production is carried out in accordance with European Standards:

- EN12413 for grinding wheels made of bonded abrasives
- EN13236 for grinding wheels made of diamond or boron nitride
- EN13743 for special abrasives on an underlay such as vulcanised fibre grinding wheels, flap grinding wheels, flap discs and mounted points.

On account of the fact that in the approval principles (EN-Standard) very high requirements are set on the grinding tools concerning defined technical grinding parameters, TYROLIT basically delivers all grinding tools corresponding to these principles. As a result we guarantee a constantly high safety level, also in countries without compulsory approvals.

## Final Inspection

TYROLIT is constantly doing final inspections concerning imbalance, bursting tests, cutting & grinding tests according to EN12413.

Resin bonded products undergo a final inspection regarding a visual and identification test, a geometry, imbalance, bursting and side load test as well as a control grinding and cutting process.

Resin and ceramic bonded products undergo a final inspection regarding a visual and identification test, a geometry, imbalance, bursting and side load test as well as a test run, a sound test.



## Safety

The following plays an equal part when it comes to safety when grinding: machine manufacturer, grinding wheel producer and user.

Grinding wheels are subject to a high load during the grinding process. This is why grinding machines, grinding bodies, handling and application must be optimally harmonised to ensure safe grinding. For the grinding machines, it is generally important to observe the machine conditions and the stipulation of the protection cover.

Whereas the manufacturer implements the safety measures in line with regulations in relation to the grinding machine and grinding wheels, the user is responsible for safety when grinding through use of the grinding machine for the intended purpose, as well as through correct handling and application of the grinding wheels.

### the following must be observed:

- Checking of grinding bodies on delivery
- Handling and storage of grinding bodies
- Labelling, synchronisation with machine data
- Checking of grinding wheels prior to clamping
- Clamping methods for grinding wheels
- Test run of grinding bodies prior to start-up
- Eye protection and protective clothing (see also FEPA safety code)

## Storage of the grinding wheels

Grinding wheels are to be stored in suitable racks or containers so that they are not damaged and so that it is easily possible to remove wheels without disturbing the storage setup. Older stock should be used first.

### During storage, the following must be noted

Store the grinding wheels in a dry, rust-free condition and do not expose grinding wheels to large temperature fluctuations.

### Storage for different types of grinding bodies

- Store cut-off wheels on a level underlay without intermediate layers and weigh them down with a steel or cast iron plate
- Store large straight grinding wheels in an upright position and make sure they cannot roll away
- Stack cylinder wheels, cylindrical grinding discs and grinding plates using soft intermediate layers
- Stack grinding discs, shape 11, in each cases faces or bases together
- Store small grinding wheels in suitable containers

## Checking of grinding wheels on delivery

Check packaging on delivery. If damage is visible on the packaging, the grinding wheel should be checked particularly thoroughly for any possible transport damage.

## Identification of the grinding wheels

The purpose of the identification is to give people, in particular those who carry out the clamping of the grinding wheels, information for safe use and proper application.

### grinding wheels may only be used if they are identified with the following minimum information

- manufacturer,
- dimensions of grinding wheel,
- material (at least the type of bond),
- maximum permissible RPM of new grinding wheel and maximum operating speed in m/s.

The user is obliged to match the machine speed to the maximum permissible speed given in the identification.

## Checking of grinding wheels prior to clamping

Each time before clamping, the grinding wheels must be cleaned and checked for damage by means of visual inspection.

The sound test should be repeated. Damaged grinding wheels must not be mounted.

For the sound test, lightweight grinding wheels are pushed onto a mandrel or shaft, heavy grinding wheels are placed on a firm floor.

The grinding wheel is tapped with a non-metal object at several points.

An undamaged grinding wheel gives a clear ring, while a damaged one gives a dull or clanking sound.

All contact surfaces on grinding wheels, intermediate layers and wheel flanges must be level (flat) and be free from foreign bodies. Foreign particles between grinding wheels and wheel flanges create pressure points and stresses, which can lead to breakage of the grinding wheel.

## Clamping methods for grinding wheels

Depending on the type of machine and grinding method, as well as the grinding wheel shape, a distinction can be made between the following clamping methods

- Mounting in the central bore using wheel flanges
- Mounting using embedded fixing elements
- Mounting using support plates
- Mounting using clamping head

### Mounting in the central bore using wheel flanges

A distinction should be made between the following wheel flange types for central bores

- recessed wheel flange
- straight wheel flanges for portable grinding machines
- special flanges
- stepped flanges
- locating flanges and tapered wheel flanges.

The purpose of the wheel flanges is to transfer drive forces. They must therefore be in such a condition that there is no deformation of the wheel flange during clamping. The contact surfaces must be level (flat) and must not show any burring, and the run-out of the grinding wheel must be safeguarded.

Only wheel flanges that have the same external diameter and the same shape on the contact side may be used. They must be recessed so that only a ring-shaped area of the wheel flange is on the surface.

### Clamping using embedded fixing elements

The grinding wheels are fixed using embedded fixing elements on the grinding machine. Examples of this are the clamping of cylindrical and taper cup wheels, or the fixing of mounted points with embedded steel shafts in collets on portable grinding machines.

### Clamping of grinding wheels on support plates

The grinding wheels are either cemented or fixed with inserted nuts.

### Clamping of grinding segments in clamping heads

Grinding segments are clamped to one grinding unit (segment head) in clamping heads. On the contact surfaces between the grinding segments and the clamping pieces, adhesive strips can be placed on the grinding segments to avoid stresses in the grinding segments.

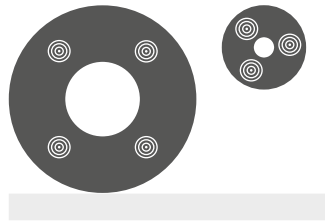

⊙ Examples of tapping points during the sound test

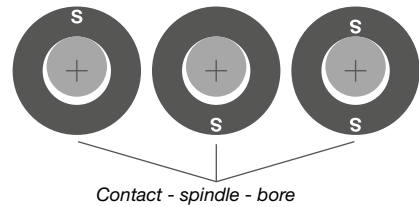

Examples of identifying wheel orientation

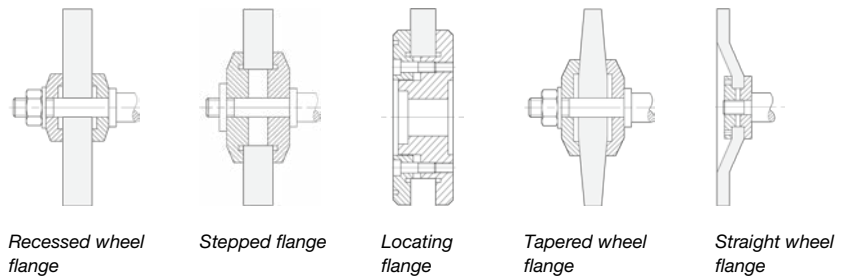

Recessed wheel flange

Stepped flange

Locating flange

Tapered wheel flange

Straight wheel flange

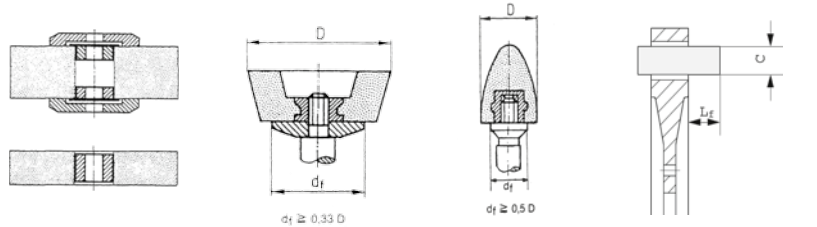

Example of the correct way to use reducing rings

Clamping of taper cup wheels with a thread insert

Clamping of a grinding cone, shape 16, with a thread insert

Clamping of grinding segments in clamping heads  $L_f = 1.5 C$

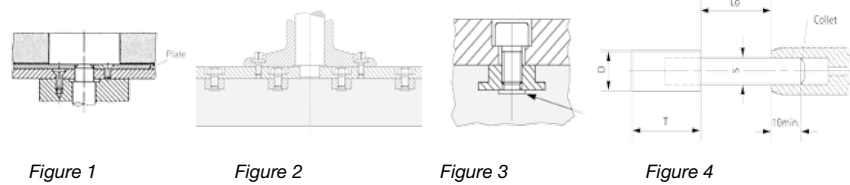

Figure 1

Figure 2

Figure 3

Figure 4

Fig. 1: Grinding wheel, cemented

Fig. 2: Grinding wheel with inserted nuts

Fig. 3: Correct bolt connection, bolt end must not touch the base of the grinding wheel

Fig. 4: Clamping of mounted points

## Test run prior to start-up

Every standard grinding wheel (D greater than 80mm) must undergo a test run at maximum operating speed before being used for the first time and after every re-mounting.

The duration of a test run for grinding wheels is on portable grinding machines 1/2 minute and on all other grinding machines 1 minute.

The test run may only be carried out once the danger zone has been secured and – where the grinding wheel must be used with the machine guard – this has been placed on it. The grinding wheel can only be used for the intended work once the test run has been passed without complaint.

## Summary

The most important points for safe use of grinding wheels are summarised again below:

- Adjustment of the machine data to the identification data
- Checking of grinding wheels prior to mounting
- Mounting carried out by skilled people
- Checking of the functionality of the machine guard
- Test run of grinding wheels prior to grinding work
- Personal safety

## Eye protection and protective clothing

All grinding tasks where people are at risk from flying particles off grinding wheels or workpieces must only be carried out using eye protection (safety glasses) and when necessary, other protective clothing (e.g. leather apron and leather gloves).

## SAFETY INFORMATION



Use gloves



Use dust mask



Wet grinding



Not permitted for side grinding



Use eye protection



Personal safety



Dry grinding



No freehand work



Use ear protection



Pay attention to the safety recommendations



Do not use damaged wheels



Fe, S, Cl Frei



## DO'S & DON'TS

- ✓ Handle and store grinding tools carefully; use the oldest tools first.
- ✓ Prior to mounting or use, grinding wheels must be cleaned and undergo a visual check for cracks or possible damage.
- ✓ Ceramic bonded grinding tools must undergo a sound check before mounting.
- ✓ Make sure that the speed of the machine (RPM) does not exceed the maximum operating speed specified on the packaging or on the abrasive.
- ✓ Ensure that the bore of the grinding tool – with or without thread – fits the shaft of the machine perfectly; and that the wheel flanges are clean, flat, the same size and suitable for the grinding tool to be clamped.
- ✓ As intended or supplied, use the intermediate layers between the grinding wheel and wheel flanges.
- ✓ Only use machines with protection/guards and ensure their proper condition and fixture before the machine is switched on.
- ✓ After each mounting, carry out a test run for at least one minute at the operating speed and ensure machine guard is mounted correctly. In doing so, ensure that any fragments would not be able to hit you or someone else in the event of a possible breakage.
- ✓ Eye protection is always recommended for all grinding processes. For off-hand grinding, protective goggles or a safety mask is recommended.
- ✓ When working with cut-off or roughing wheels, ensure that the air supply and protective measures sufficiently correspond with the material to be processed. Suitable extraction systems should be fitted for all dry grinding processes.
- ✓ Only use machines that are also suitable for grinding tools with hub.
- ✓ Before stopping the machine, cut off the supply of cooling lubricant and remove the excess cooling lubricant from the grinding wheel.
- × Do not use abrasives that are exposed to particularly humid/wet conditions or high temperatures prior to mounting.
- × Never use abrasives that have been dropped, damaged or that look like they would not be fit for purpose.
- × Never exceed the maximum permissible operating speed specified.
- × Do not use wheel flanges with surfaces that are not free of foreign bodies (e. g. grinding swarf), flat or burr-free.
- × Do not tighten the clamping device or wheel flange too much.
- × Do not use recessed wheel flanges or flanges with recesses for grinding discs or cones.
- × Never use force when clamping and do not make any changes to the grinding tool.
- × Only use one-way adapters (hubs) once.
- × Only switch on the machine when the protection cover is correctly and securely fixed (machine guards or covers should be set in such a way that they divert sparks and grinding particles away from the body).
- × Only start the machine if there is no contact between the workpiece and the grinding tool.
- × Never work with grinding tools without sufficient air supply (never without breathing apparatus and ear protection, particularly in enclosed spaces) and without personal safety equipment (see pictogram).
- × Use a suitable grinding tool – an unsuitable product can create excessive grinding particles and dust.
- × Avoid mechanical damage to the grinding wheel as a result of force effects, jolting or heating.
- × Never use grinding machines in an improper condition or that contain faulty components.
- × Do not use cut-off wheels for grinding work (do not exert a lateral load on any cut-off wheels of shape 41 or 42).
- × Never mount more than one grinding tool on one shaft.

# SPEED RECOMMENDATIONS

Rotational speeds and peripheral speeds depending on the external diameter  $\varnothing=D$  of the grinding wheels.

Rotations n per minute min <sup>-1</sup> depends on external diameter D of grinding wheel and the maximum operating speed $V_s$											
D in mm	Maximum operating speed $V_s$ in m/s										
	16	20	25	32	35	40	50	63	80	100	125
3											
4	75.300	95.400									
5	61.100	76.300	95.400								
6	50.900	63.600	79.500								
8	38.100	47.700	59.600	76.300	83.500	95.400					
10	30.500	38.100	47.700	61.100	66.800	76.300	95.400				
13	23.500	29.300	36.700	47.000	51.400	58.700	73.400	92.500			
16	19.000	23.800	29.800	38.100	41.700	47.700	59.600	75.200	95.400		
20	15.200	19.000	23.800	30.500	33.400	38.100	47.700	60.100	76.300	95.400	
25	12.200	15.200	19.000	24.400	26.700	30.500	38.100	48.100	61.100	76.300	95.400
32	9.540	11.900	14.900	19.000	20.800	23.800	29.800	37.600	47.700	59.600	74.600
35	8.730	10.900	13.600	17.400	19.000	21.800	27.200	34.300	43.600	54.400	68.200
40	7.630	9.540	11.900	15.200	16.700	19.000	23.800	30.000	38.100	47.700	59.600
50	6.110	7.630	9.540	12.200	13.300	15.200	19.000	24.000	30.500	38.100	47.700
63	4.850	6.060	7.570	9.700	10.600	12.100	15.100	10.000	24.200	30.300	37.800
80	3.810	4.770	5.960	7.630	8.350	9.540	11.900	15.000	19.000	23.800	29.800
100	3.050	3.810	4.770	6.110	6.680	7.630	9.540	12.000	15.200	19.000	23.800
115	2.650	3.320	4.150	5.310	5.810	6.640	8.300	10.400	13.200	16.600	20.700
125	2.440	3.050	3.810	4.880	5.340	6.110	7.630	9.620	12.200	15.200	19.000
150	2.030	2.540	3.180	4.070	4.450	5.090	6.360	8.020	10.100	12.700	15.900
175	1.740	2.180	2.720	3.490	3.810	4.360	5.450	6.870	8.730	10.900	13.600
180	1.690	2.120	2.650	3.390	3.710	4.240	5.300	6.680	8.480	10.600	13.200
200	1.520	1.900	2.380	3.050	3.340	3.810	4.770	6.010	7.630	9.540	11.900
225	1.350	1.690	2.120	2.710	2.970	3.390	4.240	5.340	6.790	8.480	10.600
230	1.320	1.660	2.070	2.650	2.900	3.320	4.150	5.230	6.640	8.300	10.300
250	1.220	1.520	1.900	2.440	2.670	3.050	3.810	4.810	6.110	7.630	9.540
300	1.010	1.270	1.590	2.030	2.220	2.540	3.180	4.010	5.090	6.360	7.950
350	870	1.090	1.360	1.740	1.900	2.180	2.720	3.430	4.360	5.450	6.820
400	760	950	1.190	1.520	1.670	1.900	2.380	3.000	3.810	4.770	5.960
450	670	840	1.060	1.350	1.480	1.690	2.120	2.670	3.390	4.240	5.300
500	610	760	950	1.220	1.330	1.520	1.900	2.400	3.050	3.810	4.770
600	500	630	790	1.010	1.110	1.270	1.590	2.000	2.540	3.180	3.970
700	430	540	680	870	950	1.090	1.360	1.710	2.180	2.720	3.410
750	400	500	630	810	890	1.010	1.270	1.600	2.030	2.540	3.180
800	380	470	590	760	830	950	1.190	1.500	1.900	2.380	2.980
900	330	420	530	670	740	840	1.060	1.330	1.690	2.120	2.650
1000	300	380	470	610	660	760	950	1.200	1.520	1.900	2.380
1060	280	360	450	570	630	720	900	1.130	1.440	1.800	2.250
1250	250	310	390	500	550	630	790	1.000	1.270	1.590	1.980
1500	200	250	310	400	440	500	630	800	1.010	1.270	1.590



## **QUICK PRODUCT SEARCH**

# INDEX

All of the typical terms and product names used at TYROLIT can be found here.  
The list will help you to find the right product.

## CUTTING CHAPTER

	Page
2in1 BASIC*	33
2in1 PREMIUM***	28
ACCU	24
CERABOND	26
CUT AND GRIND	30
DEEP CUT PROTECTION	25
FOCUR Extra PREMIUM***	30
FOCUR SA for angle grinders	30
FOCUR SA for stationary cutting machines	54
LAB	56
LONGLIFE	27
Super-thin cut-off wheels	21

## GRINDING CHAPTER

	Page
2in1 BASIC*	82
2in1 PREMIUM***	72
3in1 PREMIUM***	74
CERABOND	71
COMFORT START	71
CONFLEX 2in1	74
CONFLEX for stainless steel	77
FASTCUT 2in1	82
FOCUR	81
FOCUR EXTRA PREMIUM***	79
FOCUR EXTRA VIBSTAR	79
LONGLIFE	70
PIPELINER 2in1	82
RONDELLER®	87
SILENTIO 2in1	74
SILENTIO stainless steel	76

## GRINDING CHAPTER

	Page
T-GRIND	78
TOUCH	83
VIBSTAR stainless steel	76

## BRUSHING CHAPTER

	Page
Hand-operated brushes	160
Tapered brushes	136
Wire brushes	143
Round brushes for bench grinders	154
Round brushes for angle grinders	137
Shaft mounted round brushes	147
SHIELD cup brushes	133
Cup brushes	134
Shaft mounted cup brushes	145

## COATED ABRASIVES CHAPTER

	Page
2in1 BASIC*	181
2in1 PREMIUM***	174
2in1 STANDARD**	179
CERABOND	176
CERAMIC	177
COMBI	175
CONDITIONING	186
ELASTIC RONDELLER®	189
FASTCUT	173
LONGLIFE for steel	170
LONGLIFE for steel and stainless steel	172
NATURAL JUTE DISC	198
OVERLAP	174
POLISH	186



# INDEX

All of the typical terms and product names used at TYROLIT can be found here. The list will help you to find the right product.

## COATED ABRASIVES CHAPTER

















	Page
POLISTAR	188
PRE-POLISH	186
QUICK CHANGE DISC	218
SCM QUICK CHANGE DISC	224
SCM SURFACE CONDITIONING MATERIAL belts	254
SCM SURFACE CONDITIONING MATERIAL discs	212
SOFTJOB for straight grinders	222
SOFTJOB for angle grinders	181
TFC TYROLIT FAST CHANGE for dual action sanders	284
TFC TYROLIT FAST CHANGE for angle grinders	207
Fleece rolls	271
Fleece sheets	179

## DIAMOND TOOLS CHAPTER



















	Page
FASTCUT	309
LONGLIFE	331
SILENT	309
4in1	308
2in1 PREMIUM***	329
TGD® dry cutting saw blades	308
TURBO grinding discs	321

# PRODUCT FINDER

## CUTTING







		Tool	Page	
	Angle grinder	 LONGLIFE super-thin cut-off wheels for steel PREMIUM***	21	
		LONGLIFE cut-off wheel for steel PREMIUM***	27	
		Cut-off wheel for steel STANDARD**	31	
			Super-thin cut-off wheel for stainless steel PREMIUM***	22
		Cut-off wheel for stainless steel PREMIUM***	28	
		Cut-off wheel for stainless steel STANDARD**	32	
		Cut-off wheel for stainless steel BASIC*	34	
			Super-thin cut-off wheels for nonferrous metals PREMIUM***	23
		Cut-off wheel for nonferrous metals PREMIUM***	29	
			FOCUR EXTRA cut-off wheel for cast iron PREMIUM***	30
			Cut-off wheel for stone STANDARD**	32
		Cut-off wheel for stone BASIC*	35	
			Super-thin 2in1 cut-off wheels steel/stainless steel PREMIUM***	22
		CERABOND 2in1 cut-off wheel steel/stainless steel PREMIUM***	26	
		2in1 cut-off wheel steel/stainless steel PREMIUM***	28	
		ACCU 2in1 cut-off wheel steel/stainless steel PREMIUM***	24	
		DEEP CUT PROTECTION 2in1 cut-off wheel steel/stainless steel PREMIUM***	25	
		CUT AND GRIND with DEEP CUT PROTECTION 2in1 for steel/stainless steel PREMIUM***	30	
		CUT AND GRIND 2in1 for steel/stainless steel PREMIUM***	31	
		CUT AND GRIND 2in1 for steel/stainless steel BASIC*	33	
		2in1 cut-off wheel steel/stainless steel BASIC*	33	
			2in1 cut-off wheel nonferrous metals/stone PREMIUM***	26
			4in1 dry cutting saw blade for universal building materials PREMIUM***	308
FASTCUT dry cutting saw blade for universal building materials PREMIUM***	309			
SILENT dry cutting saw blade for universal building materials PREMIUM***	309			
Dry cutting saw blade for universal building materials STANDARD**	314			
FASTCUT dry cutting saw blade for universal building materials STANDARD**	314			
Dry cutting saw blade for universal building materials BASIC*	315			
FASTCUT dry cutting saw blade for universal building materials BASIC*	315			
	Dry cutting saw blade for concrete PREMIUM***	310		
Dry cutting saw blade for concrete STANDARD**	314			
	Dry cutting saw blade for hard stone PREMIUM***	311		
FASTCUT dry cutting saw blade for hard stone PREMIUM***	312			
Dry cutting saw blade for hard stone BASIC*	315			
	Dry cutting saw blade for tiles PREMIUM***	312		
Dry cutting saw blade for tiles BASIC*	316			
	Dry cutting saw blade for soft stone PREMIUM***	313		
	Dry-cutting saw blade for abrasive materials PREMIUM***	313		
Tuck point blade for abrasive materials PREMIUM***	313			
Dry-cutting saw blade for abrasive materials BASIC*	316			
	Straight grinder	 Cut-off wheel for steel PREMIUM***	40	
		 Cut-off wheel for stainless steel PREMIUM***	40	

**CUTTING**









		<b>Tool</b>	<b>Page</b>
	Petrol cutting saw	 Cut-off wheel for steel PREMIUM***	44
		Cut-off wheel for steel STANDARD**	45
		Cut-off wheel for steel BASIC*	46
		 Cut-off wheel for rails preMIUM***	44
		Cut-off wheel for rails stanDarD**	46
		 Cut-off wheel for stone PREMIUM***	45
		Cut-off wheel for stone STANDARD**	46
		Cut-off wheel for stone BASIC*	47
		 4in1 dry cutting saw blade for universal building materials PREMIUM***	326
		Dry cutting saw blade for universal building materials PREMIUM**	327
		FASTCUT dry cutting saw blade for universal building materials STANDARD**	330
		Dry cutting saw blade for universal building materials STANDARD**	330
		FASTCUT dry cutting saw blade for universal building materials BASIC*	333
		Dry cutting saw blade for universal building materials BASIC*	332
		 2in1 dry cutting saw blade for concrete PREMIUM***	329
		Dry cutting saw blade for concrete PREMIUM***	327
		LONGLIFE dry cutting saw blade for concrete STANDARD**	331
		Dry cutting saw blade for concrete STANDARD**	331
 DTGD dry cutting saw blade for hard stone PREMIUM***	328		
Dry cutting saw blade for hard stone PREMIUM***	329		
Dry cutting saw blade for hard stone BASIC*	333		
 Dry cutting saw blade for asphalt PREMIUM***	329		
2in1 dry cutting saw blade for asphalt PREMIUM***	329		
Dry cutting saw blade for asphalt STANDARD**	332		
Dry cutting saw blade for asphalt BASIC*	334		
	Stationary cutting machines	 Cut-off wheel for steel PREMIUM***	52
		LAB cut-off wheel for steel PREMIUM***	57
		Cutting and saw sharpening for steel PREMIUM***	58
		Cut-off wheel for steel STANDARD**	54
		Cut-off wheel for steel BASIC*	55
		 Cut-off wheel for stainless steel PREMIUM***	53
		LAB cut-off wheel for stainless steel PREMIUM***	57
		 Cut-off wheel for nonferrous metals PREMIUM***	53
		LAB cut-off wheel for nonferrous metals PREMIUM***	57
		 Cut-off wheel for stone PREMIUM***	54
		 LAB cut-off wheel for titanium PREMIUM***	57
		 Cutting and saw sharpening for HSS PREMIUM***	60
Cut-off wheel for HSS PREMIUM***	60		
 Cut-off wheel for tungsten carbide PREMIUM***	60		
	Floor saws	 2in1 diamond floor saw blade for asphalt PREMIUM***	339
		Diamond floor saw blade for asphalt PREMIUM***	338
		Diamond floor saw blade for asphalt BASIC*	339
		 2in1 diamond floor saw blade for concrete PREMIUM***	339
		Diamond floor saw blade for cured concrete PREMIUM***	338
		Diamond floor saw blade for concrete BASIC*	338

**SAWING**



**SAWING**

		Tool	Page
	Table saws	 Diamond saw for universal building materials PREMIUM***	344
		 Diamond saw for universal building materials STANDARD**	346
		 Diamond saw for soft stone PREMIUM***	344
		 Diamond saw for tiles PREMIUM***	345
		 Diamond saw for hard stone PREMIUM***	345
		 Diamond saw for abrasive materials PREMIUM***	345

**DRILLING**

















	Dry drilling	 Dry drill bits for universal building materials PREMIUM***	350
		 Dry drill bits for universal building materials STANDARD**	351
		 Dry drill bits for universal building materials BASIC*	351
		 Tile drill for universal building materials PREMIUM***	354
	Wet drilling	 Wet drill bits for concrete PREMIUM***	358
		 Thin-walled wet drill bits for concrete PREMIUM***	360

**GRINDING**

	Angle grinder		LONGLIFE rough grinding wheel for steel PREMIUM***	70	
			Rough grinding wheel for steel STANDARD**	80	
			T-Grind rough grinding wheel for steel PREMIUM***	78	
			Rondeller for steel PREMIUM***	87	
			Resin cup wheels for steel PREMIUM***	92	
			LONGLIFE flap disc for steel PREMIUM***	170	
			Flap disc for steel PREMIUM***	171	
			Resin cup wheels for steel STANDARD**	93	
			Polishing paste polishing program for steel PREMIUM***	188	
			JUTE disc for steel PREMIUM***	198	
			Vulcanized fibre disc for steel PREMIUM***	200	
			Tyrolit Fast Change for steel PREMIUM***	207	
			CERABOND 2in1 rough grinding wheel steel/stainless steel PREMIUM***	2in1 rough grinding wheel steel/stainless steel PREMIUM***	71
				2in1 rough grinding wheel steel/stainless steel PREMIUM***	72
				SILENTIO 2in1 rough grinding wheel steel/stainless steel PREMIUM***	74
				CONFLEX 2in1 rough grinding wheel steel/stainless steel PREMIUM***	74
				2in1 rough grinding wheel steel/stainless steel BASIC*	82
				FASTCUT 2in1 rough grinding wheel steel/stainless steel BASIC*	82
				PIPELINER 2in1 rough grinding wheel steel/stainless steel BASIC*	82
				CUT AND GRIND 2in1 steel/stainless steel PREMIUM***	30
				CERABOND 2in1 flap disc steel/stainless steel PREMIUM***	176
				LONGLIFE 2in1 flap disc steel/stainless steel PREMIUM***	172
				FASTCUT 2in1 flap disc steel/stainless steel PREMIUM***	173
				OVERLAP 2in1 flap disc steel/stainless steel PREMIUM***	174
				2in1 flap disc steel/stainless steel PREMIUM***	174
				COMBI 2in1 flap disc steel/stainless steel PREMIUM***	175
				2in1 flap disc steel/stainless steel STANDARD**	179
				SOFTJOB 2in1 flap disc steel/stainless steel STANDARD**	181
				2in1 flap disc steel/stainless steel BASIC*	181
				CONDITIONING 2in1 polishing program steel/stainless steel PREMIUM***	186
				PRE-POLISH 2in1 polishing program steel/stainless steel PREMIUM***	186
				ELASTIC RONDELLER 2in1 steel/stainless steel PREMIUM***	189



















**GRINDING**























	Tool	Page
	Angle grinder	 2in1 rough cleaning wheel steel/stainless steel STANDARD** 193 Cut & Grind 2in1 steel/stainless steel BASIC* 33
		 3in1 rough grinding wheel steel/stainless steel/cast iron PREMIUM*** 74
		 Rough grinding wheel for stainless steel PREMIUM*** 75 VIBSTAR rough grinding wheel for stainless steel PREMIUM*** 76 SILENTIO rough grinding wheel for stainless steel PREMIUM*** 76 CONFLEX rough grinding wheel for stainless steel PREMIUM*** 77 Rough grinding wheel for stainless steel STANDARD** 81 Touch grinding wheel for stainless steel BASIC* 83 Resin cup wheels for stainless steel PREMIUM*** 92 CERAMIC flap disc for stainless steel PREMIUM*** 177 Polishing paste polishing program for stainless steel PREMIUM*** 187 JUTE disc for stainless steel PREMIUM*** 199 Vulcanized fibre disc for stainless steel PREMIUM*** 201
	 Rough grinding wheel for nonferrous metals PREMIUM*** 77 Touch grinding wheel for nonferrous metals BASIC* 83 Flap disc for nonferrous metals PREMIUM*** 179 Polishing paste polishing program for nonferrous metals PREMIUM*** 187 JUTE disc for nonferrous metals PREMIUM*** 198 Vulcanized fibre disc for nonferrous metals PREMIUM*** 205 TYROLIT FAST CHANGE for nonferrous metals PREMIUM*** 207	
	 T-Grind rough grinding wheel for cast iron PREMIUM*** 78 FOCUR Extra rough grinding wheel for cast iron PREMIUM*** 79 FOCUR Extra VIBSTAR rough grinding wheel for cast iron PREMIUM*** 79 FOCUR rough grinding wheel for cast iron STANDARD** 81 Rough grinding wheel for cast iron BASIC* 83	
	 Rough grinding wheel for stone PREMIUM*** 80 Rough grinding wheel for stone STANDARD** 81 Rough grinding wheel for stone BASIC* 83 Rondeller for stone PREMIUM*** 88 Resin cup wheels for stone PREMIUM*** 92 Resin cup wheels for stone STANDARD** 93 Polistar for stone PREMIUM*** 188	
	 Diamond cup wheel for universal building materials PREMIUM*** 320 Diamond cup wheel for universal building materials STANDARD** 320	
	 Diamond cup wheel for abrasive materials PREMIUM*** 320	
	 Rondeller for plastic PREMIUM*** 188 ELASTIC RONDELLER for plastic PREMIUM*** 189 Rough cleaning wheel for plastic STANDARD** 193	
	 Tyrolit Fast Change for composite materials PREMIUM*** 207	
	 Vulcanized fibre disc for wood BASIC* 205	
	 TYROLIT Fast Change for gel coat PREMIUM*** 207	
	 POLISH polishing program for universal use PREMIUM*** 186 SCM discs for universal use PREMIUM*** 212	
	 ELASTIC RONDELLER for paints and lacquers PREMIUM*** 189	
	Mini angle grinder	 QUICK-CHANGE discs for steel PREMIUM*** 218 QUICK-CHANGE SCM discs for steel PREMIUM*** 224 QUICK-CHANGE rough cleaning wheel for steel PREMIUM*** 224

Notes

















**GRINDING**

		<b>Tool</b>	<b>Page</b>
	Mini angle grinder	 QUICK-CHANGE discs for steel and stainless steel PREMIUM***	219
		QUICK-CHANGE MINIDISC for steel and stainless steel PREMIUM***	221
		QUICK-CHANGE SOFTJOB discs for steel and stainless steel PREMIUM***	222
		 QUICK-CHANGE rough cleaning wheel for stainless steel PREMIUM***	224
		QUICK-CHANGE SCM discs for stainless steel PREMIUM***	224
		 QUICK-CHANGE SCM discs for nonferrous metals PREMIUM***	224
		 QUICK-CHANGE SCM discs for plastic PREMIUM***	224
		QUICK-CHANGE rough cleaning wheel for plastic PREMIUM***	224
		QUICK-CHANGE discs for plastic PREMIUM***	222
		 QUICK-CHANGE discs for wood PREMIUM***	222
		QUICK-CHANGE SCM discs for wood PREMIUM***	224
			Straight grinder
Ceramic mounted points for steel PREMIUM***	106		
ELASTIC mounted points for steel PREMIUM***	112		
Tungsten carbide burrs for steel PREMIUM***	118		
Spiral belts for steel PREMIUM***	230		
Rough cleaning wheel for steel STANDARD**	235		
Fleece flap wheels spindle mounted for steel PREMIUM***	240		
Mounted flap wheels for steel PREMIUM***	242		
Mounted flap wheels for steel BASIC*	247		
 1F80 grinding wheels for stainless steel PREMIUM***	98		
Resin-bonded mounted points for stainless steel PREMIUM***	105		
ELASTIC mounted points for stainless steel PREMIUM***	112		
Tungsten carbide burrs for stainless steel PREMIUM***	118		
Spiral belts for stainless steel PREMIUM***	230		
Rough cleaning wheels for stainless steel STANDARD**	235		
Fleece flap wheels spindle mounted for stainless steel PREMIUM***	240		
Mounted flap wheels for stainless steel PREMIUM***	242		
Mounted flap wheels for stainless steel BASIC*	247		
 1F80 grinding wheels for nonferrous metals PREMIUM***	99		
ELASTIC mounted points for nonferrous metals PREMIUM***	112		
Tungsten carbide burrs for nonferrous metals PREMIUM***	121		
Spiral belts for nonferrous metals PREMIUM***	230		
Fleece flap wheels spindle mounted for nonferrous metals PREMIUM***	240		
Mounted flap wheels for nonferrous metals PREMIUM***	242		
Mounted flap wheels for nonferrous metals BASIC*	247		
 1F80 grinding wheels for cast iron PREMIUM***	99		
Resin-bonded mounted points for cast iron PREMIUM***	105		
Tungsten carbide burrs for cast iron PREMIUM***	118		
 Ceramic mounted points for HSS PREMIUM***	110		
 ELASTIC mounted points for plastic PREMIUM***	112		
Rough cleaning wheel for plastic STANDARD**	235		
	Belt grinder	 Mini belts for steel PREMIUM***	252
		Belts for contact grinders for steel PREMIUM***	257
		 Mini belts for stainless steel PREMIUM***	252
		Belts for contact grinders for stainless steel PREMIUM***	257
		 Mini belts for nonferrous metals PREMIUM***	252
		Belts for contact grinders for nonferrous metals PREMIUM***	258
		 SCM mini belts for universal use	254
		Belts for portable belt grinders for universal use BASIC*	255
Belts for contact grinders for universal use PREMIUM***	261		
SCM belts for contact grinders for universal use PREMIUM***	261		

**GRINDING**

		<b>Tool</b>	<b>Page</b>	
	Hand-guided grinding		Paper rolls for steel PREMIUM***	266
			Paper sheets for steel PREMIUM***	276
			Cloth rolls for steel BASIC*	276
			Paper rolls for nonferrous metals PREMIUM***	266
			Paper sheets for nonferrous metals PREMIUM***	276
			Cloth rolls for nonferrous metals BASIC*	276
			Paper rolls for paints and lacquers PREMIUM***	266
			Paper sheets for paints and lacquers PREMIUM***	266
			Paper sheets for paints and lacquers BASIC*	276
			Paper rolls for paints and lacquers BASIC*	277
			Paper rolls for wood PREMIUM***	266
			Paper sheets for wood PREMIUM***	276
			Paper sheets for wood BASIC*	277
			Paper rolls for wood BASIC*	266
			Cloth rolls for wood BASIC*	266
	Cloth rolls for universal use BASIC*	267		
	Fleece rolls for universal use PREMIUM***	271		
	Cloth sheets for universal use BASIC*	277		
	Fleece sheets for universal use BASIC*	279		
	Dual action sander		TYROLIT Fast Change for steel PREMIUM***	286
			TYROLIT Fast Change for composite materials PREMIUM***	286
			TYROLIT Fast Change for gel coat PREMIUM***	284
			TYROLIT Fast Change for wood PREMIUM***	284
			TYROLIT Fast Change for plastic PREMIUM***	284
			TYROLIT Fast Change for soft stone PREMIUM***	286
	Burnishing machine		Rollers for steel PREMIUM***	292
			Spiral rollers for steel PREMIUM***	293
			Rough cleaning rollers for steel PREMIUM***	294
			Rollers for stainless steel PREMIUM***	292
			Spiral rollers for stainless steel PREMIUM***	293
			Rough cleaning rollers for stainless steel PREMIUM***	294
			Rollers for nonferrous metals PREMIUM***	292
			Spiral rollers for nonferrous metals PREMIUM***	293
			Rough cleaning rollers for plastic PREMIUM***	294
	Floorstand grinder		Rollers for steel PREMIUM***	298
			Rollers for stainless steel PREMIUM***	298
			Rollers for nonferrous metals PREMIUM***	298

**BRUSHES**

		Tool		Page		
	Angle grinder		SHIELD cup brushes for steel PREMIUM***	133		
			Cup brushes for steel PREMIUM***	134		
			Tapered brush for steel PREMIUM***	136		
			Round brush for steel PREMIUM***	137		
			SHIELD cup brushes for stainless steel PREMIUM***	134		
			Cup brushes for stainless steel PREMIUM***	135		
			Tapered brush for stainless steel PREMIUM***	136		
			Round brush for stainless steel PREMIUM***	137		
			Cup brush for nonferrous metals PREMIUM***	137		
			Straight grinder		Wire brush for steel PREMIUM***	143
					Shaft mounted cup brush for steel PREMIUM***	145
					Shaft mounted round brushes for steel PREMIUM***	147
	Wire brush for stainless steel PREMIUM***			144		
	Shaft mounted cup brush for stainless steel PREMIUM***			146		
	Shaft mounted round brushes for stainless steel PREMIUM***			148		
	Wire brush for nonferrous metals PREMIUM***			144		
	Shaft mounted cup brush for nonferrous metals PREMIUM***			146		
	Shaft mounted round brushes for nonferrous metals PREMIUM***			148		
	Wire brush for universal use PREMIUM***			145		
	Shaft mounted cup brush for universal use PREMIUM***			147		
	Shaft mounted round brushes for universal use PREMIUM***			149		
	Floorstand grinder				Round brush for steel PREMIUM***	154
					Round brush for stainless steel PREMIUM***	155
					Round brush for universal use PREMIUM***	155
	Hand-guided grinding		Hand-guided tool brush for steel PREMIUM***	160		
			Hand-guided tool brush for stainless steel PREMIUM***	160		
			Hand-guided tool brush for nonferrous metals PREMIUM***	161		



# INDEX-TYPE NO.

Type No.	EAN product	EAN packaging	Page
108	9003170001083	9009010001084	109
109	9003170001090	9009010001091	109
113	9003170001137	9009010001138	109
116	9003170001168	9009010001169	109
118	9003170001182	9009010001183	109
121	9003170001212	9009010001213	109
128	9003170001281	9009010001282	109
130	9003170001304	9009010001305	109
131	9003170001311	9009010001312	109
138	9003170001380	9009010001381	109
139	9003170001397	9009010001398	109
169	9003170001694	9009010001695	109
174	9003170001748	9009010001749	109
190	9003170001908	9009010001909	109
191	9003170001915	9009010001916	109
892	9003170008921	9009010008922	110
907	9003170009072	9009010009073	110
910	9003170009102	9009010009103	110
917	9003170009171	9009010009172	110
921	9003170009218	9009010009219	110
923	9003170009232		112
925	9003170009256		112
929	9003170009294		112
1119	9003170011198	9009010011199	110
1175	9003170011754	9009010011755	110
1197	9003170011976	9009010011977	58
1211	9003170012119	9009010012110	58
1254	9003170012546	9009010012547	59
1649	9003170016490	9009010016491	54
1999	9003170019996	9009010019997	110
2010	9003170020107	9009010020108	106
2011	9003170020114	9009010020115	110
2017	9003170020176	9009010020177	106
2020	9003170020206	9009010020207	110
2021	9003170020213	9009010020214	106
2026	9003170020268	9009010020269	106

Type No.	EAN product	EAN packaging	Page
2027	9003170020275	9009010020276	107
2030	9003170020305	9009010020306	110
2031	9003170020312	9009010020313	107
2039	9003170020398	9009010020399	107
2046	9003170020466	9009010020467	107
2048	9003170020480	9009010020481	107
2055	9003170020558	9009010020559	107
2057	9003170020572	9009010020573	111
2058	9003170020589	9009010020580	107
2060	9003170020602	9009010020603	107
2062	9003170020626	9009010020627	107
2072	9003170020725	9009010020726	107
2078	9003170020787	9009010020788	107
2081	9003170020817	9009010020818	107
2090	9003170020909	9009010020900	107
2111	9003170021111	9009010021112	105
2117	9003170021173	9009010021174	107
2125	9003170021258	9009010021259	107
2133	9003170021333	9009010021334	107
2134	9003170021340	9009010021341	107
2145	9003170021456	9009010021457	107
2148	9003170021487	9009010021488	107
2152	9003170021524	9009010021525	112
2155	9003170021555	9009010021556	112
2163	9003170021630	9009010021631	107
2165	9003170021654	9009010021655	107
2180	9003170021807	9009010021808	111
2189	9003170021890	9009010021891	108
2201	9003170022019	9009010022010	108
2202	9003170022026	9009010022027	108
2204	9003170022040	9009010022041	108
2209	9003170022095	9009010022096	108
2211	9003170022118	9009010022119	105
2221	9003170022217	9009010022218	112
2222	9003170022224	9009010022225	112
2224	9003170022248	9009010022249	112

Type No.	EAN product	EAN packaging	Page	Type No.	EAN product	EAN packaging	Page
2226	9003170022262	9009010022263	112	5689	9003170056892		345
2238	9003170022385	9009010022386	108	5692	9003170056922		344
2248	9003170022484	9009010022485	108	5693	9003170056939		344
2249	9003170022491	9009010022492	105	5696	9003170056960		344
2256	9003170022569	9009010022560	108	5707	9003170057073		344
2258	9003170022583	9009010022584	105	5708	9003170057080		344
2276	9003170022767	9009010022768	108	5715	9003170057158		344
2284	9003170022842	9009010022843	106	5720	9003170057202		344
5267	9003170052672	9009010052673	74	5721	9003170057219		344
5270	9003170052702	9009010052703	72	5723	9003170057233		344
5279	9003170052795	9009010052796	70	6207	9003170062077	9009010062078	109
5287	9003170052870	9009010052871	72	6400	9003170064002	9009010064003	110
5288	9003170052887	9009010052888	70	6401	9003170064019	9009010064010	110
5289	9003170052894	9009010052895	77	6402	9003170064026	9009010064027	110
5294	9003170052948	9009010052949	70	6404	9003170064040	9009010064041	110
5295	9003170052955	9009010052956	77	6405	9003170064057	9009010064058	110
5306	9003170053068	9009010053069	70	6411	9003170064118		112
5308	9003170053082	9009010053083	72	6413	9003170064132		112
5314	9003170053143	9009010053144	70	6660	9003170066600	9009010066601	110
5316	9003170053167	9009010053168	77	6661	9003170066617	9009010066618	110
5331	9003170053310	9009010053311	70	6673	9003170066730	9009010066731	58
5349	9003170053495	9009010053496	73	6710	9003170067102	9009010067103	59
5350	9003170053501	9009010053502	70	6718	9003170067188	9009010067189	59
5351	9003170053518	9009010053519	77	6874	9003170068741	9009010068742	111
5363	9003170053631	9009010053632	70	6879	9003170068796	9009010068797	107
5365	9003170053655	9009010053656	77	6881	9003170068819	9009010068810	111
5368	9003170053686	9009010053687	80	6884	9003170068840	9009010068841	112
5384	9003170053846	9009010053847	70	6886	9003170068864	9009010068865	111
5396	9003170053969	9009010053960	70	6896	9003170068963	9009010068964	107
5406	9003170054065	9009010054066	73	6898	9003170068987	9009010068988	107
5407	9003170054072	9009010054073	70	6899	9003170068994	9009010068995	107
5413	9003170054133	9009010054134	70	6910	9003170069106	9009010069107	111
5416	9003170054164	9009010054165	77	6915	9003170069151	9009010069152	112
5425	9003170054256	9009010054257	80	6920	9003170069205	9009010069206	107
5429	9003170054294	9009010054295	70	6928	9003170069281	9009010069282	107
5485	9003170054850	9009010054851	29	6932	9003170069328	9009010069329	107
5684	9003170056847		344	6941	9003170069410	9009010069411	108
5685	9003170056854		344	6943	9003170069434	9009010069435	108
5687	9003170056878		345	6949	9003170069496	9009010069497	112
5688	9003170056885		345	6957	9003170069571	9009010069572	286

Type No.	EAN product	EAN packaging	Page
6958	9003170069588	9009010069589	286
6959	9003170069595	9009010069596	108
6960	9003170069601	9009010069602	286
6961	9003170069618	9009010069619	108
6964	9003170069649	9009010069640	286
6967	9003170069670	9009010069671	108
6968	9003170069687	9009010069688	287
6969	9003170069694	9009010069695	287
6974	9003170069748	9009010069749	108
6979	9003170069793	9009010069794	287
6991	9003170069915	9009010069916	287
6993	9003170069939	9009010069930	287
7007	9003170070072	9009010070073	287
7008	9003170070089	9009010070080	287
7030	9003170070300	9009010070301	287
7055	9003170070553	9009010070554	287
7058	9003170070584	9009010070585	287
7070	9003170070706	9009010070707	287
7072	9003170070720	9009010070721	287
7086	9003170070867	9009010070868	287
7087	9003170070874	9009010070875	287
7093	9003170070935	9009010070936	287
7100	9003170071000	9009010071001	287
7213	9003170072137		155
8434	9003170084345	9009010084346	189
8833	9003170088336	9009010088337	59
9292	9003170092920	9009010092921	45
10051	9003170100519	9009010100510	189
10054	9003170100540	9009010100541	189
10055	9003170100557	9009010100558	189
10056	9003170100564	9009010100565	189
10058	9003170100588	9009010100589	189
11362	9003170113625	9009010113626	107
11480	9003170114806	9009010114807	109
11481	9003170114813	9009010114814	109
12836	9003170128360	9009010128361	108
12970	9003170129701	9009010129702	59
13068	9003170130684	9009010130685	112
13529	9003170135290	9009010135291	110
13616	9003170136167	9009010136168	77

Type No.	EAN product	EAN packaging	Page
13695	9003170136952	9009010136953	58
14082	9003170140829	9009010140820	22
14085	9003170140850	9009010140851	22
14364	9003170143646	9009010143647	107
15383	9003170153836	9009010153837	108
15685	9003170156851	9009010156852	59
15892	9003170158923	9009010158924	111
16044	9003170160445	9009010160446	107
16118	9003170161183	9009010161184	21
16121	9003170161213	9009010161214	21
16422	9003170164221		137
16425	9003170164252		137
16427	9003170164276		137
16746	9003170167468	9009010167469	144
19012	9003170190121	9009010190122	143
20020	9003170200202	9009010200203	109
20023	9003170200233	9009010200234	109
20026	9003170200264	9009010200265	106
20031	9003170200318	9009010200319	109
20037	9003170200370	9009010200371	109
20047	9003170200479	9009010200470	109
20487	9003170204873		121
20553	9003170205535		121
20555	9003170205559		121
20557	9003170205573		121
20565	9003170205658		121
20587	9003170205870		121
20590	9003170205900		121
20781	9003170207812		269
20793	9003170207935		269
20794	9003170207942		269
20796	9003170207966		269
20797	9003170207973		269
20798	9003170207980		269
20799	9003170207997		269
20801	9003170208017		269
20803	9003170208031		269
20805	9003170208055		269
20806	9003170208062		269
20807	9003170208079		269

Type No.	EAN product	EAN packaging	Page	Type No.	EAN product	EAN packaging	Page
20811	9003170208116		269	23525	9003170235259	9009010235250	92
20813	9003170208130		269	23875	9003170238755	9009010238756	72
20816	9003170208161		269	25590	9003170255905	9009010255906	58
20817	9003170208178		269	26567	9003170265676	9009010265677	107
20819	9003170208192		269	28692	9003170286923	9009010286924	54
20821	9003170208215		269	29238	9003170292382	9009010292383	110
20822	9003170208222		269	30741	9003170307413	9009010307414	29
20824	9003170208246		269	32023	9003170320238	9009010320239	59
20832	9003170208321	9009010208322	278	32141	9003170321419	9009010321410	29
20833	9003170208338	9009010208339	278	32142	9003170321426	9009010321427	29
20834	9003170208345	9009010208346	278	33199	9003170331999	9009010331990	87
20835	9003170208352	9009010208353	278	33436	9003170334365	9009010334366	59
20836	9003170208369	9009010208360	278	35917	9003170359177	9009010359178	58
20842	9003170208420	9009010208421	278	35937	9003170359375	9009010359376	29
20844	9003170208444	9009010208445	278	35944	9003170359443	9009010359444	29
20851	9003170208512	9009010208513	278	35946	9003170359467	9009010359468	29
20860	9003170208604	9009010208605	278	35950	9003170359504	9009010359505	29
20868	9003170208680	9009010208681	278	36663	9003170366632	9009010366633	111
21094	9003170210942	9009010210943	106	37348	9003170373487	9009010373488	52
21125	9003170211253	9009010211254	106	39110	9003170391108	9009010391109	59
21137	9003170211376	9009010211377	106	39128	9003170391283	9009010391284	109
21160	9003170211604	9009010211605	106	39321	9003170393218	9009010393219	29
21166	9003170211666	9009010211667	106	39624	9003170396240	9009010396241	29
21192	9003170211925	9009010211926	106	41489	9003170414890	9009010414891	28
21202	9003170212021	9009010212022	106	41491	9003170414913	9009010414914	28
21232	9003170212328	9009010212329	106	41492	9003170414920	9009010414921	28
21233	9003170212335	9009010212336	106	41493	9003170414937	9009010414938	28
21239	9003170212397	9009010212398	106	41494	9003170414944	9009010414945	29
21262	9003170212625		188	41495	9003170414951	9009010414952	29
21273	9003170212731	9009010212732	112	41499	9003170414999	9009010414990	29
21381	9003170213813		200	41501	9003170415019	9009010415010	29
22373	9003170223737		326	41504	9003170415040	9009010415041	29
22377	9003170223775		326	41505	9003170415057	9009010415058	29
23469	9003170234696	9009010234697	146	41506	9003170415064	9009010415065	29
23470	9003170234702	9009010234703	146	41507	9003170415071	9009010415072	29
23471	9003170234719	9009010234710	146	41508	9003170415088	9009010415089	29
23472	9003170234726	9009010234727	148	41509	9003170415095	9009010415096	29
23473	9003170234733	9009010234734	148	41510	9003170415101	9009010415102	29
23474	9003170234740	9009010234741	148	41511	9003170415118	9009010415119	29
23509	9003170235099	9009010235090	92	41513	9003170415132	9009010415133	29



Type No.	EAN product	EAN packaging	Page
42808	9003170428088	9009010428089	59
42809	9003170428095	9009010428096	59
43485	9003170434850		328
43490	9003170434904		328
45362	9003170453622	9009010453623	105
45421	9003170454216	9009010454217	109
45422	9003170454223	9009010454224	109
45919	9003170459198	9009010459199	77
46586	9003170465861	9009010465862	77
46633	9003170466332	9009010466333	58
47763	9003170477635	9009010477636	77
49856	9003170498562	9009010498563	242
50801	9003170508018	9009010508019	180
51392	9003170513920		354
51470	9003170514705		
51825	9003170518253	9009010518254	21
51838	9003170518383	9009010518384	21
51841	9003170518413	9009010518414	22
51844	9003170518444	9009010518445	23
52433	9003170524339		188
52679	9003170526791	9009010526792	143
54072	9003170540728	9009010540729	112
56895	9003170568951	9009010568952	93
56918	9003170569187	9009010569188	53
57004	9003170570046	9009010570047	87
57005	9003170570053	9009010570054	87
57006	9003170570060	9009010570061	87
58157	9003170581578	9009010581579	53
58158	9003170581585	9009010581586	59
58293	9003170582933	9009010582934	143
59543	9003170595438		326
59545	9003170595452		326
59580	9003170595803		326
60159	9003170601597		292
60170	9003170601702		292
60184	9003170601849		292
60185	9003170601856		292
60337	9003170603379		292
60351	9003170603515		292
60352	9003170603522		292

Type No.	EAN product	EAN packaging	Page
60354	9003170603546		292
60572	9003170605724	9009010605725	60
62144	9003170621441		292
62153	9003170621533		292
62154	9003170621540		292
62155	9003170621557		292
62178	9003170621786		292
62180	9003170621809	9009010621800	298
62181	9003170621816	9009010621817	298
62190	9003170621908	9009010621909	298
62194	9003170621946	9009010621947	298
62197	9003170621977	9009010621978	298
62202	9003170622028	9009010622029	298
62212	9003170622127	9009010622128	298
62239	9003170622394	9009010622395	298
62258	9003170622585	9009010622586	298
62274	9003170622745	9009010622746	298
62277	9003170622776	9009010622777	298
62291	9003170622912	9009010622913	298
62298	9003170622981	9009010622982	298
62299	9003170622998	9009010622999	298
62304	9003170623049	9009010623040	298
62332	9003170623322	9009010623323	298
62334	9003170623346	9009010623347	298
62342	9003170623421	9009010623422	298
62353	9003170623537		298
62384	9003170623841		298
62409	9003170624091		298
62416	9003170624169		298
62419	9003170624190		298
62434	9003170624343		298
62436	9003170624367		298
62437	9003170624374		298
62448	9003170624480		298
62453	9003170624534		298
62471	9003170624718		298
62484	9003170624848		299
62491	9003170624916		299
62505	9003170625050		299
62506	9003170625067		299

Type No.	EAN product	EAN packaging	Page	Type No.	EAN product	EAN packaging	Page
62507	9003170625074		299	82125	9003170821254	9009010821255	244
62516	9003170625166		299	82127	9003170821278	9009010821279	244
62518	9003170625180		299	82256	9003170822565	9009010822566	246
62521	9003170625210		299	82257	9003170822572	9009010822573	246
62524	9003170625241		299	82646	9003170826464	9009010826465	29
62547	9003170625470		299	83585	9003170835855	9009010835856	93
62548	9003170625487		299	83618	9003170836180	9009010836181	44
62694	9003170626941	9009010626942	109	84363	9003170843638	9009010843639	52
62726	9003170627269	9009010627260	29	87215	9003170872157	9009010872158	22
62874	9003170628747	9009010628748	59	87216	9003170872164	9009010872165	22
66490	9003170664905	9009010664906	53	87910	9003170879101	9009010879102	246
66491	9003170664912	9009010664913	53	88461	9003170884617	9009010884618	58
66493	9003170664936	9009010664937	53	88504	9003170885041	9009010885042	109
69766	9003170697668		354	88905	9003170889056	9009010889057	107
69767	9003170697675		354	89383	9003170893831	9009010893832	93
69768	9003170697682		354	89504	9003170895040	9009010895041	109
69769	9003170697699		354	94110	9003170941105	9009010941106	53
69833	9003170698337		354	94134	9003170941341		293
69848	9003170698481		354	94204	9003170942041		293
69855	9003170698559		354	94210	9003170942102		293
69856	9003170698566		354	94223	9003170942232		293
69860	9003170698603		354	94234	9003170942348		293
74499	9003170744997		111	94237	9003170942379		293
75020	9003170750202	9009010750203	44	96205	9003170962056	9009010962057	59
75193	9003170751933	9009010751934	171	97442	9003170974424	9009010974425	59
75647	9003170756471	9009010756472	109	97785	9003170977852	9009010977853	109
75934	9003170759342	9009010759343	46	100660	9003171006605		60
75935	9003170759359	9009010759350	46	100757	9003171007572	9009011007573	106
75936	9003170759366	9009010759367	46	100758	9003171007589	9009011007580	106
75937	9003170759373	9009010759374	46	101000	9003171010008		60
75938	9003170759380	9009010759381	46	101508	9003171015089	9009011015080	108
75939	9003170759397	9009010759398	46	102811	9003171028119		30
78049	9003170780490	9009010780491	174	102813	9003171028133		30
79957	9003170799577	9009010799578	59	102814	9003171028140		54
80143	9003170801430	9009010801431	59	102831	9003171028317		54
80653	9003170806534		334	102850	9003171028508		54
82070	9003170820707	9009010820708	243	102855	9003171028553		54
82078	9003170820783	9009010820784	243	102856	9003171028560		54
82079	9003170820790	9009010820791	243	102859	9003171028591		54
82117	9003170821179	9009010821170	244	103394	9003171033946	9009011033947	108

Type No.	EAN product	EAN packaging	Page
104604	9003171046045	9009011046046	105
104894	9003171048940	9009011048941	109
104962	9003171049626	9009011049627	105
104968	9003171049688	9009011049689	105
105009	9003171050097	9009011050098	108
105367	9003171053678	9009011053679	105
106372	9003171063721	9009011063722	109
108261	9003171082616	9009011082617	105
108262	9003171082623	9009011082624	105
108728	9003171087284		60
111562	9003171115628	9009011115629	221
111567	9003171115673	9009011115674	221
111570	9003171115703	9009011115704	221
111577	9003171115772	9009011115773	221
111584	9003171115840	9009011115841	221
111585	9003171115857	9009011115858	221
111611	9003171116113	9009011116114	221
111631	9003171116311	9009011116312	221
112203	9003171122039	9009011122030	221
112204	9003171122046	9009011122047	221
112205	9003171122053	9009011122054	221
112242	9003171122428	9009011122429	221
112253	9003171122534	9009011122535	221
112254	9003171122541	9009011122542	221
112268	9003171122688	9009011122689	221
112273	9003171122732	9009011122733	221
112279	9003171122794	9009011122795	221
112283	9003171122831	9009011122832	221
112298	9003171122985	9009011122986	221
112308	9003171123081	9009011123082	221
112309	9003171123098	9009011123099	221
112312	9003171123128	9009011123129	222
112320	9003171123203	9009011123204	222
112322	9003171123227	9009011123228	222
112337	9003171123371	9009011123372	222
112339	9003171123395	9009011123396	222
112359	9003171123593	9009011123594	222
112398	9003171123982	9009011123983	219
112401	9003171124019	9009011124010	219
112406	9003171124064	9009011124065	219

Type No.	EAN product	EAN packaging	Page
112411	9003171124118	9009011124119	219
112413	9003171124132	9009011124133	219
112418	9003171124187	9009011124188	219
112432	9003171124323	9009011124324	219
112438	9003171124385	9009011124386	219
112440	9003171124408	9009011124409	219
112447	9003171124477	9009011124478	219
112449	9003171124491	9009011124492	219
112452	9003171124521	9009011124522	219
112455	9003171124552	9009011124553	219
112469	9003171124699	9009011124690	219
112471	9003171124712	9009011124713	219
112486	9003171124866	9009011124867	219
112493	9003171124934	9009011124935	219
112494	9003171124941	9009011124942	219
112505	9003171125054	9009011125055	219
112510	9003171125108	9009011125109	219
112514	9003171125146	9009011125147	219
112527	9003171125276	9009011125277	219
112532	9003171125320	9009011125321	219
112536	9003171125368	9009011125369	219
112542	9003171125429	9009011125420	107
112543	9003171125436	9009011125437	223
112546	9003171125467	9009011125468	223
112550	9003171125504	9009011125505	223
112551	9003171125511	9009011125512	223
112581	9003171125818	9009011125819	223
112588	9003171125887	9009011125888	223
112589	9003171125894	9009011125895	223
112590	9003171125900	9009011125901	223
112591	9003171125917	9009011125918	223
112592	9003171125924	9009011125925	223
112593	9003171125931	9009011125932	223
112599	9003171125993	9009011125994	223
112602	9003171126020	9009011126021	223
112603	9003171126037	9009011126038	223
112917	9003171129175	9009011129176	220
112918	9003171129182	9009011129183	220
112923	9003171129236	9009011129237	220
112924	9003171129243	9009011129244	220

Type No.	EAN product	EAN packaging	Page
112928	9003171129281	9009011129282	220
112934	9003171129342	9009011129343	220
112935	9003171129359	9009011129350	220
112937	9003171129373	9009011129374	220
112947	9003171129472	9009011129473	220
112948	9003171129489	9009011129480	220
112950	9003171129502	9009011129503	221
112961	9003171129618	9009011129619	221
112988	9003171129885	9009011129886	221
113007	9003171130072	9009011130073	221
113023	9003171130232	9009011130233	221
113026	9003171130263	9009011130264	221
113027	9003171130270	9009011130271	221
113031	9003171130317	9009011130318	221
113057	9003171130577	9009011130578	221
113059	9003171130591	9009011130592	221
113299	9003171132991	9009011132992	111
116061	9003171160611	9009011160612	218
116065	9003171160659	9009011160650	218
116097	9003171160970	9009011160971	218
116111	9003171161113	9009011161114	218
116115	9003171161151	9009011161152	218
116127	9003171161274	9009011161275	218
116130	9003171161304	9009011161305	218
116143	9003171161434	9009011161435	218
116152	9003171161526	9009011161527	218
116156	9003171161564	9009011161565	218
116263	9003171162639		353
116264	9003171162646		352
116725	9003171167252	9009011167253	107
116973	9003171169737	9009011169738	108
117058	9003171170580	9009011170581	75
117064	9003171170641	9009011170642	75
117065	9003171170658	9009011170659	75
117068	9003171170689	9009011170680	75
117070	9003171170702	9009011170703	75
117071	9003171170719	9009011170710	75
117072	9003171170726	9009011170727	75
117073	9003171170733	9009011170734	75
117074	9003171170740	9009011170741	75

Type No.	EAN product	EAN packaging	Page
119395	9003171193954		60
120033	9003171200331	9009011200332	107
120093	9003171200935	9009011200936	111
120653	9003171206531		271
120667	9003171206678		271
120671	9003171206715		271
120674	9003171206746		271
120676	9003171206760		271
120682	9003171206821		271
120688	9003171206883		271
120689	9003171206890		271
120693	9003171206937		271
120694	9003171206944		271
120700	9003171207002		271
120716	9003171207163		271
120769	9003171207699	9009011207690	279
120770	9003171207705	9009011207706	279
120772	9003171207729	9009011207720	279
120774	9003171207743	9009011207744	279
120777	9003171207774	9009011207775	279
120779	9003171207798	9009011207799	279
120781	9003171207811	9009011207812	279
120787	9003171207873	9009011207874	279
121385	9003171213850	9009011213851	111
121878	9003171218787	9009011218788	28
122567	9003171225679		362
122569	9003171225693		362
122868	9003171228687	9009011228688	108
123432	9003171234329	9009011234320	112
123644	9003171236446	9009011236447	106
123696	9003171236965	9009011236966	106
124549	9003171245493	9009011245494	111
126460	9003171264609	9009011264600	106
127347	9003171273472	9009011273473	107
127775	9003171277753	9009011277754	109
128345	9003171283457		155
128618	9003171286182	9009011286183	107
129260	9003171292602	9009011292603	106
130009	9003171300093	9009011300094	108
131231	9003171312317	9009011312318	108



Type No.	EAN product	EAN packaging	Page
131779	9003171317794		224
131783	9003171317831		224
131784	9003171317848		224
131786	9003171317862		224
132438	9003171324389	9009011324380	109
135853	9003171358537	9009011358538	109
136087	9003171360875	9009011360876	240
136090	9003171360905	9009011360906	240
136161	9003171361612	9009011361613	240
136164	9003171361643	9009011361644	240
136168	9003171361681	9009011361682	241
136173	9003171361735	9009011361736	241
136193	9003171361933	9009011361934	241
136777	9003171367775	9009011367776	52
139648	9003171396485	9009011396486	180
139651	9003171396515	9009011396516	180
139653	9003171396539	9009011396530	180
140022	9003171400229	9009011400220	52
140351	9003171403510	9009011403511	107
141512	9003171415124	9009011415125	44
142682	9003171426823	9009011426824	108
146601	9003171466010	9009011466011	109
148132	9003171481327		60
148517	9003171485172	9009011485173	109
148718	9003171487183	9009011487184	241
148722	9003171487220	9009011487221	241
150085	9003171500851	9009011500852	108
150465	9003171504651	9009011504652	205
150467	9003171504675	9009011504676	206
150468	9003171504682	9009011504683	206
150469	9003171504699	9009011504690	206
150473	9003171504736	9009011504737	206
151301	9003171513011	9009011513012	52
151928	9003171519280	9009011519281	109
154544	9003171545449	9009011545440	81
154545	9003171545456	9009011545457	81
157800	9003171578003		60
160229	9003171602296	9009011602297	173
160230	9003171602302	9009011602303	173
160235	9003171602357	9009011602358	173

Type No.	EAN product	EAN packaging	Page
160240	9003171602401	9009011602402	173
160242	9003171602425	9009011602426	173
160244	9003171602449	9009011602440	173
160245	9003171602456	9009011602457	173
160246	9003171602463	9009011602464	173
160247	9003171602470	9009011602471	173
160249	9003171602494	9009011602495	173
160251	9003171602517	9009011602518	173
160252	9003171602524	9009011602525	173
160254	9003171602548	9009011602549	173
160255	9003171602555	9009011602556	173
160256	9003171602562	9009011602563	173
160257	9003171602579	9009011602570	173
160258	9003171602586	9009011602587	173
160260	9003171602609	9009011602600	173
162390	9003171623901	9009011623902	112
164485	9003171644852		60
165940	9003171659405	9009011659406	57
167205	9003171672053	9009011672054	57
167207	9003171672077	9009011672078	57
167210	9003171672107	9009011672108	57
167211	9003171672114	9009011672115	57
167214	9003171672145	9009011672146	57
167215	9003171672152	9009011672153	57
167219	9003171672190	9009011672191	57
167220	9003171672206	9009011672207	57
167221	9003171672213	9009011672214	57
167225	9003171672251	9009011672252	57
167226	9003171672268	9009011672269	57
167229	9003171672299	9009011672290	58
167333	9003171673333	9009011673334	57
167334	9003171673340	9009011673341	57
167335	9003171673357	9009011673358	58
167336	9003171673364	9009011673365	58
167338	9003171673388	9009011673389	57
167339	9003171673395	9009011673396	57
167340	9003171673401	9009011673402	57
167342	9003171673425	9009011673426	58
167344	9003171673449	9009011673440	57
167351	9003171673517	9009011673518	57

Type No.	EAN product	EAN packaging	Page
167352	9003171673524	9009011673525	57
167354	9003171673548	9009011673549	58
169096	9003171690965	9009011690966	106
169477	9003171694772	9009011694773	57
169479	9003171694796	9009011694797	57
169543	9003171695434	9009011695435	106
170530	9003171705300	9009011705301	24
170542	9003171705423	9009011705424	24
170567	9003171705676	9009011705677	24
170580	9003171705805	9009011705806	24
170586	9003171705867	9009011705868	24
170587	9003171705874	9009011705875	24
170599	9003171705997	9009011705998	87
175115	9003171751154		344
181071	9003171810714	9009011810715	44
183113	9003171831139	9009011831130	21
183114	9003171831146	9009011831147	21
183592	9003171835922	9009011835923	45
188495	9003171884951		346
196324	9003171963243	9009011963244	52
199648	9003171996487	9009011996488	148
199649	9003171996494	9009011996495	146
199657	9003171996579	9009011996570	160
199658	9003171996586	9009011996587	161
199678	9003171996784	9009011996785	161
199682	9003171996821	9009011996822	160
199689	9003171996890	9009011996891	160
202159	9003172021591	9009012021592	58
203258	9003172032580		346
205056	9003172050560	9009012050561	198
205058	9003172050584	9009012050585	198
205060	9003172050607	9009012050608	198
205822	9003172058221	9009012058222	59
220394	9003172203942	9009012203943	60
222042	9003172220420	9009012220421	35
222043	9003172220437	9009012220438	83
222044	9003172220444	9009012220445	34
222045	9003172220451	9009012220452	47
222854	9003172228549	9009012228540	82
222858	9003172228587	9009012228588	82

Type No.	EAN product	EAN packaging	Page
222860	9003172228600	9009012228601	82
222861	9003172228617	9009012228618	82
222863	9003172228631	9009012228632	82
222865	9003172228655	9009012228656	82
222868	9003172228686	9009012228687	82
222870	9003172228709	9009012228700	82
222872	9003172228723	9009012228724	83
222873	9003172228730	9009012228731	83
222889	9003172228891	9009012228892	83
222892	9003172228921	9009012228922	83
222893	9003172228938	9009012228939	34
222894	9003172228945	9009012228946	34
222896	9003172228969	9009012228960	34
222898	9003172228983	9009012228984	83
222899	9003172228990	9009012228991	33
222900	9003172229003	9009012229004	34
222996	9003172229966	9009012229967	33
222997	9003172229973	9009012229974	33
222998	9003172229980	9009012229981	34
222999	9003172229997	9009012229998	34
223000	9003172230009	9009012230000	34
223002	9003172230023	9009012230024	34
223010	9003172230108	9009012230109	35
223012	9003172230122	9009012230123	35
223015	9003172230153	9009012230154	35
223016	9003172230160	9009012230161	35
223019	9003172230191	9009012230192	35
223020	9003172230207	9009012230208	34
223021	9003172230214	9009012230215	34
223022	9003172230221	9009012230222	34
223023	9003172230238	9009012230239	34
223024	9003172230245	9009012230246	35
223025	9003172230252	9009012230253	35
223027	9003172230276	9009012230277	35
223029	9003172230290	9009012230291	35
223031	9003172230313	9009012230314	35
223032	9003172230320	9009012230321	55
223033	9003172230337	9009012230338	55
223035	9003172230351	9009012230352	46
223037	9003172230375	9009012230376	46

Type No.	EAN product	EAN packaging	Page
223039	9003172230399	9009012230390	46
223040	9003172230405	9009012230406	46
223042	9003172230429	9009012230420	47
223043	9003172230436	9009012230437	47
223129	9003172231297	9009012231298	47
223131	9003172231310	9009012231311	47
223132	9003172231327	9009012231328	47
223134	9003172231341	9009012231342	47
223135	9003172231358	9009012231359	47
223136	9003172231365	9009012231366	47
223516	9003172235165	9009012235166	59
227165	9003172271651	9009012271652	59
227435	9003172274355		155
227450	9003172274508	9009012274509	107
230691	9003172306919	9009012306910	59
233756	9003172337562	9009012337563	79
233757	9003172337579	9009012337570	79
233759	9003172337593	9009012337594	79
233760	9003172337609	9009012337600	79
233762	9003172337623	9009012337624	79
233765	9003172337654	9009012337655	79
233768	9003172337685	9009012337686	79
233771	9003172337715	9009012337716	79
233773	9003172337739	9009012337730	79
233774	9003172337746	9009012337747	79
233776	9003172337760	9009012337761	79
233777	9003172337777	9009012337778	79
233778	9003172337784	9009012337785	79
236317	9003172363172	9009012363173	83
236318	9003172363189	9009012363180	83
236319	9003172363196	9009012363197	83
236320	9003172363202	9009012363203	83
239448	9003172394480	9009012394481	241
241413	9003172414133	9009012414134	92
242270	9003172422701	9009012422702	108
243069	9003172430690	9009012430691	180
243071	9003172430713	9009012430714	180
246870	9003172468709	9009012468700	182
246871	9003172468716	9009012468717	182
246872	9003172468723	9009012468724	182

Type No.	EAN product	EAN packaging	Page
246982	9003172469829	9009012469820	225
246984	9003172469843	9009012469844	225
246985	9003172469850	9009012469851	225
246986	9003172469867	9009012469868	225
246987	9003172469874	9009012469875	181
246988	9003172469881	9009012469882	181
246990	9003172469904	9009012469905	181
246994	9003172469942	9009012469943	181
246995	9003172469959	9009012469950	181
246996	9003172469966	9009012469967	181
246998	9003172469980	9009012469981	181
247001	9003172470016	9009012470017	181
247165	9003172471655	9009012471656	180
247175	9003172471754	9009012471755	181
247366	9003172473666	9009012473667	181
250165	9003172501659	9009012501650	34
250169	9003172501697	9009012501698	34
252911	9003172529110		351
252912	9003172529127		351
252913	9003172529134		351
252914	9003172529141		351
252915	9003172529158		351
252916	9003172529165		351
252917	9003172529172		351
252918	9003172529189		351
252919	9003172529196		351
252920	9003172529202		351
252921	9003172529219		351
252923	9003172529233		351
252924	9003172529240		351
255450	9003172554501	9009012554502	45
255451	9003172554518	9009012554519	44
257533	9003172575339	9009012575330	24
257768	9003172577685	9009012577686	179
263249	9003172632490	9009012632491	241
267341	9003172673417	9009012673418	112
272894	9003172728940	9009012728941	52
273756	9003172737560	9009012737561	108
273810	9003172738109	9009012738100	181
273871	9003172738710	9009012738711	181

Type No.	EAN product	EAN packaging	Page	Type No.	EAN product	EAN packaging	Page
273872	9003172738727	9009012738728	181	293739	9003172937397	9009012937398	188
273873	9003172738734	9009012738735	181	293740	9003172937403		189
273874	9003172738741	9009012738742	182	293790	9003172937908		188
273884	9003172738840	9009012738841	181	297324	9003172973241	9009012973242	82
274654	9003172746548	9009012746549	112	297325	9003172973258	9009012973259	82
275634	9003172756349	9009012756340	92	297327	9003172973272	9009012973273	82
278979	9003172789798		60	297329	9003172973296	9009012973297	82
282077	9003172820774	9009012820775	58	297331	9003172973319	9009012973310	82
282078	9003172820781	9009012820782	58	297333	9003172973333	9009012973334	82
282079	9003172820798	9009012820799	58	299269	9003172992693	9009012992694	40
282080	9003172820804	9009012820805	58	299270	9003172992709	9009012992700	40
282085	9003172820859	9009012820850	59	307876	9003173078761	9009013078762	44
282105	9003172821054	9009012821055	59	309469	9003173094693	9009013094694	52
282110	9003172821108	9009012821109	58	309471	9003173094716	9009013094717	53
282111	9003172821115	9009012821116	58	310183	9003173101834	9009013101835	92
282112	9003172821122	9009012821123	59	310184	9003173101841	9009013101842	92
282113	9003172821139	9009012821130	59	310303	9003173103036		137
282114	9003172821146	9009012821147	59	310305	9003173103050		137
282149	9003172821498	9009012821499	23	310504	9003173105047	9009013105048	106
282150	9003172821504	9009012821505	23	310980	9003173109809	9009013109800	92
284967	9003172849676		346	310992	9003173109922	9009013109923	93
284968	9003172849683		346	310993	9003173109939	9009013109930	93
284969	9003172849690		346	310994	9003173109946	9009013109947	93
284970	9003172849706		346	310995	9003173109953	9009013109954	93
285439	9003172854397	9009012854398	74	310997	9003173109977	9009013109978	92
289327	9003172893273	9009012893274	225	311096	9003173110966	9009013110967	92
289329	9003172893297	9009012893298	225	314463	9003173144633	9009013144634	92
289330	9003172893303	9009012893304	225	315965	9003173159651		313
291583	9003172915838	9009012915839	23	315966	9003173159668		313
291587	9003172915876	9009012915877	23	315967	9003173159675		313
291588	9003172915883	9009012915884	23	315968	9003173159682		313
291947	9003172919478	9009012919479	34	317307	9003173173077	9009013173078	92
291948	9003172919485	9009012919486	34	317532	9003173175323		60
291949	9003172919492	9009012919493	34	318070	9003173180709	9009013180700	92
293641	9003172936413	9009012936414	188	320074	9003173200742	9009013200743	93
293643	9003172936437	9009012936438	188	320075	9003173200759	9009013200750	93
293644	9003172936444	9009012936445	188	320318	9003173203187	9009013203188	182
293645	9003172936451	9009012936452	188	320319	9003173203194	9009013203195	182
293737	9003172937373	9009012937374	188	320320	9003173203200	9009013203201	182
293738	9003172937380	9009012937381	188	320321	9003173203217	9009013203218	182



Type No.	EAN product	EAN packaging	Page
320322	9003173203224	9009013203225	182
320323	9003173203231	9009013203232	182
320335	9003173203354	9009013203355	26
321211	9003173212110	9009013212111	93
321395	9003173213957	9009013213958	92
323970	9003173239704	9009013239705	40
323978	9003173239780	9009013239781	40
324303	9003173243039	9009013243030	40
324402	9003173244029	9009013244020	40
324404	9003173244043	9009013244044	40
325212	9003173252123	9009013252124	40
325219	9003173252192	9009013252193	40
325222	9003173252222	9009013252223	40
325224	9003173252246	9009013252247	40
325228	9003173252284	9009013252285	40
326214	9003173262146	9009013262147	93
330772	9003173307724	9009013307725	110
331314	9003173313145	9009013313146	40
336499	9003173364994	9009013364995	93
337383	9003173373835	9009013373836	26
338399	9003173383995		346
342583	9003173425831	9009013425832	92
342978	9003173429785	9009013429786	26
348387	9003173483879		320
350694	9003173506943		320
351386	9003173513866	9009013513867	92
351693	9003173516935	9009013516936	44
355251	9003173552513	9009013552514	46
355613	9003173556139		346
355631	9003173556313		346
355633	9003173556337		346
356569	9003173565698		320
359471	9003173594711		362
359472	9003173594728		362
359473	9003173594735		362
359474	9003173594742		362
359475	9003173594759		362
359476	9003173594766		362
363478	9003173634783	9009013634784	44
366794	9003173667941	9009013667942	44

Type No.	EAN product	EAN packaging	Page
366888	9003173668887	9009013668888	29
367377	9003173673775	9009013673776	80
367545	9003173675458	9009013675459	81
367546	9003173675465	9009013675466	81
367548	9003173675489	9009013675480	81
367549	9003173675496	9009013675497	81
367550	9003173675502	9009013675503	81
367551	9003173675519	9009013675510	81
367552	9003173675526	9009013675527	81
367553	9003173675533	9009013675534	81
367554	9003173675540	9009013675541	81
367556	9003173675564	9009013675565	81
367557	9003173675571	9009013675572	81
367561	9003173675618	9009013675619	32
367562	9003173675625	9009013675626	32
367565	9003173675656	9009013675657	31
367566	9003173675663	9009013675664	32
367567	9003173675670	9009013675671	32
367568	9003173675687	9009013675688	32
367569	9003173675694	9009013675695	31
367572	9003173675724	9009013675725	32
367574	9003173675748	9009013675749	31
367575	9003173675755	9009013675756	32
367576	9003173675762	9009013675763	32
367577	9003173675779	9009013675770	32
367578	9003173675786	9009013675787	31
367580	9003173675809	9009013675800	32
367581	9003173675816	9009013675817	32
367582	9003173675823	9009013675824	32
367583	9003173675830	9009013675831	31
367585	9003173675854	9009013675855	32
367771	9003173677711	9009013677712	80
367772	9003173677728	9009013677729	80
367773	9003173677735	9009013677736	80
367775	9003173677759	9009013677750	80
367776	9003173677766	9009013677767	32
367777	9003173677773	9009013677774	32
367780	9003173677803	9009013677804	32
367781	9003173677810	9009013677811	31
367782	9003173677827	9009013677828	33

Type No.	EAN product	EAN packaging	Page
367783	9003173677834	9009013677835	32
367785	9003173677858	9009013677859	31
367786	9003173677865	9009013677866	31
367787	9003173677872	9009013677873	33
367788	9003173677889	9009013677880	32
367789	9003173677896	9009013677897	31
367791	9003173677919	9009013677910	32
367800	9003173678008	9009013678009	31
367801	9003173678015	9009013678016	33
367802	9003173678022	9009013678023	32
367803	9003173678039	9009013678030	31
367804	9003173678046	9009013678047	33
367833	9003173678336		320
368002	9003173680025	9009013680026	80
368008	9003173680087	9009013680088	81
368009	9003173680094	9009013680095	31
368010	9003173680100	9009013680101	31
368012	9003173680124	9009013680125	33
368014	9003173680148	9009013680149	81
368016	9003173680162	9009013680163	32
368017	9003173680179	9009013680170	32
372339	9003173723395	9009013723396	240
373520	9003173735206	9009013735207	60
374035	9003173740354		360
377664	9003173776643	9009013776644	92
378198	9003173781982		362
379653	9003173796535	9009013796536	105
381983	9003173819838		360
384142	9003173841426	9009013841427	22
384143	9003173841433	9009013841434	22
384753	9003173847534	9009013847535	45
384754	9003173847541	9009013847542	45
384755	9003173847558	9009013847559	45
384756	9003173847565	9009013847566	45
384757	9003173847572	9009013847573	45
384758	9003173847589	9009013847580	45
384759	9003173847596	9009013847597	46
384760	9003173847602	9009013847603	46
384761	9003173847619	9009013847610	46
384762	9003173847626	9009013847627	46

Type No.	EAN product	EAN packaging	Page
384763	9003173847633	9009013847634	46
384764	9003173847640	9009013847641	46
386001	9003173860014	9009013860015	46
386002	9003173860021	9009013860022	45
388126	9003173881262	9009013881263	240
390531	9003173905319	9009013905310	54
390532	9003173905326	9009013905327	54
396678	9003173966785	9009013966786	52
400439	9003174004394		362
401205	9003174012054	9009014012055	22
408229	9003174082293	9009014082294	52
408496	9003174084969	9009014084960	32
410277	9003174102779	9009014102770	45
415841	9003174158417	9009014158418	105
419688	9003174196884	9009014196885	44
422374	9003174223740	9009014223741	53
424846	9003174248460	9009014248461	93
432975	9003174329756	9009014329757	243
433019	9003174330196	9009014330197	245
433020	9003174330202	9009014330203	245
433039	9003174330394	9009014330395	245
433068	9003174330684	9009014330685	246
437376	9003174373766		346
439059	9003174390596	9009014390597	98
439061	9003174390619	9009014390610	98
441033	9003174410331	9009014410332	110
441203	9003174412038	9009014412039	98
441204	9003174412045	9009014412046	98
441206	9003174412069	9009014412060	98
441207	9003174412076	9009014412077	98
441219	9003174412199	9009014412190	98
441223	9003174412236	9009014412237	98
441224	9003174412243	9009014412244	98
441226	9003174412267	9009014412268	98
441227	9003174412274	9009014412275	98
441230	9003174412304	9009014412305	99
441231	9003174412311	9009014412312	98
441233	9003174412335	9009014412336	98
441238	9003174412380	9009014412381	98
441239	9003174412397	9009014412398	98

Type No.	EAN product	EAN packaging	Page	Type No.	EAN product	EAN packaging	Page
441241	9003174412410	9009014412411	98	464552	9003174645528		327
441243	9003174412434	9009014412435	98	464553	9003174645535		327
441245	9003174412458	9009014412459	98	464555	9003174645559		327
441246	9003174412465	9009014412466	99	464556	9003174645566		327
441247	9003174412472	9009014412473	99	464697	9003174646976		312
441248	9003174412489	9009014412480	99	464698	9003174646983		312
441250	9003174412502	9009014412503	99	464699	9003174646990		312
441353	9003174413530	9009014413531	99	464702	9003174647027		329
454393	9003174543930	9009014543931	180	464703	9003174647034		329
454396	9003174543961	9009014543962	180	464706	9003174647065		329
455303	9003174553038	9009014553039	180	464707	9003174647072		329
455312	9003174553120	9009014553121	180	464710	9003174647102		329
455314	9003174553144	9009014553145	180	464711	9003174647119		329
455318	9003174553182	9009014553183	179	464712	9003174647126		329
455324	9003174553243	9009014553244	179	464853	9003174648536		330
456491	9003174564911	9009014564912	34	464854	9003174648543		330
457370	9003174573708	9009014573709	240	464855	9003174648550		330
458028	9003174580287	9009014580288	173	464858	9003174648581		330
458029	9003174580294	9009014580295	173	464859	9003174648598		330
458030	9003174580300	9009014580301	173	465488	9003174654889		310
458031	9003174580317	9009014580318	173	465489	9003174654896		310
458033	9003174580331	9009014580332	173	465490	9003174654902		310
458034	9003174580348	9009014580349	173	465491	9003174654919		310
458035	9003174580355	9009014580356	173	465492	9003174654926		310
458038	9003174580386	9009014580387	173	465493	9003174654933		327
458040	9003174580409	9009014580400	173	465494	9003174654940		327
458587	9003174585879	9009014585870	180	465495	9003174654957		327
460744	9003174607441	9009014607442	53	465496	9003174654964		327
462504	9003174625049		346	465498	9003174654988		327
462506	9003174625063		346	465499	9003174654995		327
462700	9003174627005		360	465501	9003174655015		327
464537	9003174645375		309	465503	9003174655039		331
464539	9003174645399		309	465505	9003174655053		331
464540	9003174645405		309	465507	9003174655077		331
464543	9003174645436		309	465509	9003174655091		331
464544	9003174645443		309	465512	9003174655121		331
464545	9003174645450		327	465519	9003174655190		332
464546	9003174645467		327	465520	9003174655206		332
464549	9003174645498		327	465522	9003174655220		332
464551	9003174645511		327	465525	9003174655251		332

Type No.	EAN product	EAN packaging	Page
465526	9003174655268		332
465640	9003174656401		329
465640	9003174656401		338
465642	9003174656425		329
465642	9003174656425		338
465649	9003174656494		334
465650	9003174656500		334
465650	9003174656500		339
465651	9003174656517		334
465652	9003174656524		334
465652	9003174656524		339
465656	9003174656562		334
465662	9003174656623		331
465667	9003174656678		330
465672	9003174656722		316
465674	9003174656746		316
465677	9003174656777		316
465686	9003174656869		316
465976	9003174659761		313
465977	9003174659778		313
465979	9003174659792		313
465980	9003174659808		313
465982	9003174659822		329
465983	9003174659839		329
465984	9003174659846		329
465985	9003174659853		329
465987	9003174659877		329
466082	9003174660828		315
466083	9003174660835		315
466084	9003174660842		315
466086	9003174660866		315
466087	9003174660873		315
466090	9003174660903		315
466093	9003174660934		332
466094	9003174660941		332
466095	9003174660958		332
466095	9003174660958		339
466096	9003174660965		332
466098	9003174660989		332
466099	9003174660996		332

Type No.	EAN product	EAN packaging	Page
466099	9003174660996		339
466744	9003174667445	9009014667446	74
466749	9003174667490	9009014667491	74
466754	9003174667544	9009014667545	74
466762	9003174667629	9009014667620	74
466842	9003174668428		358
466843	9003174668435		358
466844	9003174668442		358
466845	9003174668459		358
466846	9003174668466		358
466847	9003174668473		358
466848	9003174668480		358
466849	9003174668497		358
466850	9003174668503		358
466852	9003174668527		358
466853	9003174668534		358
466854	9003174668541		358
466855	9003174668558		358
466856	9003174668565		358
466857	9003174668572		358
466858	9003174668589		358
466887	9003174668879		359
466888	9003174668886		359
466889	9003174668893		359
466890	9003174668909		359
466891	9003174668916		359
466892	9003174668923		359
466893	9003174668930		359
466894	9003174668947		359
466895	9003174668954		359
466896	9003174668961		359
466898	9003174668985		359
466899	9003174668992		359
466900	9003174669005		359
466902	9003174669029		359
466903	9003174669036		359
466904	9003174669043		359
467266	9003174672661		315
467267	9003174672678		315
467268	9003174672685		315



Type No.	EAN product	EAN packaging	Page	Type No.	EAN product	EAN packaging	Page
467271	9003174672715		315	474531	9003174745310	9009014745311	80
467273	9003174672739		315	474532	9003174745327	9009014745328	79
467276	9003174672760		315	474533	9003174745334	9009014745335	79
467280	9003174672807		333	474534	9003174745341	9009014745342	80
467281	9003174672814		333	474535	9003174745358	9009014745359	80
467282	9003174672821		333	474743	9003174747437		309
467285	9003174672852		333	474746	9003174747468		309
467288	9003174672883		333	474751	9003174747512		309
467289	9003174672890		333	474752	9003174747529		309
467386	9003174673866		315	474753	9003174747536		309
467387	9003174673873		315	474771	9003174747710		309
467388	9003174673880		315	474774	9003174747741		314
467389	9003174673897		315	474775	9003174747758		314
467391	9003174673910		333	474777	9003174747772		314
467392	9003174673927		333	474778	9003174747789		314
467394	9003174673941		333	474780	9003174747802		314
467395	9003174673958		333	474872	9003174748724	9009014748725	181
467396	9003174673965		333	474874	9003174748748	9009014748749	181
467400	9003174674009		333	474875	9003174748755	9009014748756	181
467414	9003174674146		314	474877	9003174748779	9009014748770	181
467416	9003174674160		314	475019	9003174750192		358
467428	9003174674283		314	475024	9003174750246		358
467430	9003174674306		314	475790	9003174757900		312
467431	9003174674313		314	475793	9003174757931		312
467433	9003174674337		330	475797	9003174757979		312
467434	9003174674344		330	475800	9003174758006		312
467435	9003174674351		330	475894	9003174758945		350
467436	9003174674368		330	475975	9003174759751		316
467439	9003174674399		330	475978	9003174759782		316
467443	9003174674436		314	475980	9003174759805		316
467444	9003174674443		314	475983	9003174759836		316
467445	9003174674450		314	475986	9003174759867		316
467446	9003174674467		314	476408	9003174764083		359
467448	9003174674481		314	476438	9003174764380		359
468182	9003174681823	9009014681824	29	476440	9003174764403		359
474524	9003174745242	9009014745243	76	476442	9003174764427		359
474526	9003174745266	9009014745267	76	476449	9003174764496		359
474527	9003174745273	9009014745274	79	476450	9003174764502		359
474528	9003174745280	9009014745281	79	476452	9003174764526		359
474529	9003174745297	9009014745298	80	476453	9003174764533		359

Type No.	EAN product	EAN packaging	Page	Type No.	EAN product	EAN packaging	Page
478074	9003174780748		362	497322	9003174973225		361
479949	9003174799498		350	499798	9003174997986		350
484627	9003174846277		361	499802	9003174998020		350
484672	9003174846727		361	499803	9003174998037		350
484994	9003174849940		331	499804	9003174998044		350
484996	9003174849964		331	500056	9003175000562		358
484999	9003174849995		331	500259	9003175002597		359
485001	9003174850014		331	500268	9003175002689		359
485003	9003174850038		331	500289	9003175002894		359
485004	9003174850045		331	514338	9003175143382	9009015143383	52
485041	9003174850410		331	514745	9003175147458	9009015147459	44
485338	9003174853381	9009014853382	107	515988	9003175159888	9009015159889	76
493199	9003174931997	9009014931998	59	515989	9003175159895	9009015159896	76
494333	9003174943334		321	519212	9003175192120	9009015192121	175
494339	9003174943396		320	519213	9003175192137	9009015192138	175
494342	9003174943426		321	519214	9003175192144	9009015192145	175
494349	9003174943495		320	519215	9003175192151	9009015192152	175
494361	9003174943617		320	519232	9003175192328	9009015192329	53
494365	9003174943655		321	525355	9003175253555	9009015253556	29
494391	9003174943914		321	528580	9003175285808	9009015285809	173
494394	9003174943945		320	529392	9003175293926	9009015293927	58
494701	9003174947011		60	529399	9003175293995		332
495674	9003174956747		360	529399	9003175293995		339
495817	9003174958178		360	529401	9003175294015		332
495818	9003174958185		360	529401	9003175294015		339
495820	9003174958208		360	529402	9003175294022		334
495824	9003174958246		360	529402	9003175294022		339
495826	9003174958260		360	529403	9003175294039		334
495830	9003174958307		360	529403	9003175294039		339
495832	9003174958321		360	529455	9003175294558		361
495833	9003174958338		360	529456	9003175294565		361
495834	9003174958345		360	532197	9003175321971		350
495836	9003174958369		360	532198	9003175321988		350
495837	9003174958376		360	532200	9003175322008		350
495838	9003174958383		360	532201	9003175322015		350
495841	9003174958413		360	532202	9003175322022		350
495842	9003174958420		360	532204	9003175322046		350
495843	9003174958437		360	532205	9003175322053		350
495844	9003174958444		360	532206	9003175322060		350
495845	9003174958451		360	532207	9003175322077		350

Type No.	EAN product	EAN packaging	Page	Type No.	EAN product	EAN packaging	Page
532208	9003175322084		350	574845	9003175748457		338
535829	9003175358298		313	574846	9003175748464		338
536789	9003175367894		314	574848	9003175748488		338
537021	9003175370214	9009015370215	180	574850	9003175748501		338
537084	9003175370849	9009015370840	180	574853	9003175748532		338
537089	9003175370894	9009015370895	180	574854	9003175748549		338
537093	9003175370931	9009015370932	180	574855	9003175748556		338
537095	9003175370955	9009015370956	180	574856	9003175748563		338
537097	9003175370979	9009015370970	180	574857	9003175748570		338
537110	9003175371105	9009015371106	180	574858	9003175748587		338
537111	9003175371112	9009015371113	180	575635	9003175756353	9009015756354	180
537112	9003175371129	9009015371120	180	576049	9003175760497	9009015760498	77
537113	9003175371136	9009015371137	180	576050	9003175760503	9009015760504	77
537114	9003175371143	9009015371144	180	579420	9003175794201		353
537115	9003175371150	9009015371151	180	579424	9003175794249		353
538503	9003175385034	9009015385035	53	579503	9003175795031		353
540688	9003175406883	9009015406884	174	580650	9003175806508	9009015806509	180
540689	9003175406890	9009015406891	174	582369	9003175823697	9009015823698	112
544172	9003175441723		359	591080	9003175910809	9009015910800	58
545254	9003175452545	9009015452546	73	591103	9003175911035	9009015911036	58
545255	9003175452552	9009015452553	73	591104	9003175911042	9009015911043	59
545256	9003175452569	9009015452560	73	591680	9003175916801	9009015916802	59
546639	9003175466399		359	594356	9003175943562	9009015943563	59
547136	9003175471362		345	594357	9003175943579	9009015943570	59
547611	9003175476114		313	594360	9003175943609	9009015943600	58
548169	9003175481699	9009015481690	108	594362	9003175943623	9009015943624	59
548170	9003175481705	9009015481706	45	596269	9003175962693	9009015962694	58
549002	9003175490028	9009015490029	60	596520	9003175965205	9009015965206	59
551616	9003175516162	9009015516163	53	596848	9003175968480	9009015968481	57
552399	9003175523993	9009015523994	31	597041	9003175970414	9009015970415	57
553403	9003175534036	9009015534037	93	597383	9003175973835	9009015973836	57
559743	9003175597437	9009015597438	53	597949	9003175979493		350
563873	9003175638734		313	597950	9003175979509		350
567352	9003175673520	9009015673521	83	598008	9003175980086		310
567353	9003175673537	9009015673538	83	598010	9003175980109		310
570473	8032973219075	9009015704737	240	598011	9003175980116		310
570485	8032973219112	9009015704850	240	598061	9003175980611		320
572473	9003175724734	9009015724735	180	598487	9003175984879	9009015984870	52
574838	9003175748389		338	598971	9003175989713	9009015989714	59
574844	9003175748440		338	599666	9003175996667	9009015996668	59

Type No.	EAN product	EAN packaging	Page
603284	9003176032845		60
603818	9003176038182		137
607744	9003176077440	9009016077441	59
608409	9003176084097	9009016084098	58
610935	9003176109356	9009016109357	22
610937	9003176109370	9009016109371	23
614644	9003176146443	9009016146444	
614686	9003176146863	9009016146864	58
615549	9003176155490	9009016155491	52
619800	9003176198008	9009016198009	242
623097	9003176230975	9009016230976	44
623553	9003176235536	9009016235537	24
630116	9003176301163	9009016301164	52
630117	9003176301170	9009016301171	52
630537	9003176305376	9009016305377	52
633286	9003176332860	9009016332861	52
633506	9003176335069	9009016335060	34
633509	9003176335090	9009016335091	34
635268	9003176352684	9009016352685	30
636399	9003176363994	9009016363995	52
636789	9003176367893	9009016367894	77
637066	9003176370664	9009016370665	27
637067	9003176370671	9009016370672	27
637068	9003176370688	9009016370689	27
637069	9003176370695	9009016370696	27
637070	9003176370701	9009016370702	27
637071	9003176370718	9009016370719	27
637072	9003176370725	9009016370726	27
637073	9003176370732	9009016370733	27
637074	9003176370749	9009016370740	27
639076	9003176390761	9009016390762	52
639558	9003176395582		312
639559	9003176395599		312
639560	9003176395605		312
639566	9003176395667		345
639568	9003176395681		345
639569	9003176395698		345
639570	9003176395704		345
639571	9003176395711		345
639635	9003176396350		312

Type No.	EAN product	EAN packaging	Page
639799	9003176397999	9009016397990	54
641977	9003176419776	9009016419777	52
642626	9003176426262	9009016426263	171
642627	9003176426279	9009016426270	171
642628	9003176426286	9009016426287	171
643371	9003176433710	9009016433711	52
643803	9003176438036	9009016438037	174
643805	9003176438050	9009016438051	175
643807	9003176438074	9009016438075	175
643823	9003176438234	9009016438235	175
643845	9003176438456	9009016438457	173
643846	9003176438463	9009016438464	173
645130	9003176451301	9009016451302	177
645132	9003176451325	9009016451326	177
645135	9003176451356	9009016451357	177
645137	9003176451370	9009016451371	178
645145	9003176451455	9009016451456	175
647216	9003176472160	9009016472161	53
647218	9003176472184	9009016472185	53
647224	9003176472245	9009016472246	53
647229	9003176472290	9009016472291	53
647232	9003176472320	9009016472321	53
647377	9003176473778	9009016473779	53
647389	9003176473891	9009016473892	53
647549	9003176475499	9009016475490	77
647550	9003176475505	9009016475506	77
647684	9003176476847	9009016476848	53
648425	9003176484255	9009016484256	243
648577	9003176485771	9009016485772	59
650292	9003176502928		351
650293	9003176502935		351
651544	9003176515447	9009016515448	29
651998	9003176519988	9009016519989	22
655529	9003176555290	9009016555291	58
661085	9003176610852	9009016610853	242
662430	9003176624309	9009016624300	59
665900	9003176659004	9009016659005	44
666221	9003176662219	9009016662210	224
666276	9003176662769	9009016662760	224
666279	9003176662790	9009016662791	224



Type No.	EAN product	EAN packaging	Page
666280	9003176662806	9009016662807	224
666421	9003176664213	9009016664214	224
667198	9003176671983	9009016671984	243
667629	9003176676292	9009016676293	108
667632	9003176676322	9009016676323	108
667995	9003176679958		60
668570	9003176685706	9009016685707	45
668630	9003176686307	9009016686308	171
668631	9003176686314	9009016686315	171
668632	9003176686321	9009016686322	171
668633	9003176686338	9009016686339	171
668634	9003176686345	9009016686346	171
668635	9003176686352	9009016686353	171
668637	9003176686376	9009016686377	171
668638	9003176686383	9009016686384	171
668640	9003176686406	9009016686407	171
668641	9003176686413	9009016686414	171
668642	9003176686420	9009016686421	174
668644	9003176686444	9009016686445	174
668649	9003176686499	9009016686490	174
668663	9003176686635	9009016686636	174
668664	9003176686642	9009016686643	174
668665	9003176686659	9009016686650	175
668670	9003176686703	9009016686704	175
668672	9003176686727	9009016686728	175
668673	9003176686734	9009016686735	175
668679	9003176686796	9009016686797	171
668681	9003176686819	9009016686810	171
668683	9003176686833	9009016686834	171
668686	9003176686864	9009016686865	175
668687	9003176686871	9009016686872	175
668691	9003176686918	9009016686919	175
668692	9003176686925	9009016686926	175
668693	9003176686932	9009016686933	175
668694	9003176686949	9009016686940	175
668696	9003176686963	9009016686964	175
668697	9003176686970	9009016686971	175
668698	9003176686987	9009016686988	175
671090	9003176710903	9009016710904	44
671093	9003176710934	9009016710935	44

Type No.	EAN product	EAN packaging	Page
671108	9003176711085	9009016711086	44
674471	9003176744717	9009016744718	22
674473	9003176744731	9009016744732	23
675283	9003176752835	9009016752836	59
676423	9003176764234	9009016764235	44
676428	9003176764289	9009016764280	44
676791	9003176767914		312
678198	9003176781989	9009016781980	244
679662	9003176796624	9009016796625	224
679663	9003176796631	9009016796632	224
679664	9003176796648	9009016796649	224
680369	9003176803698	9009016803699	172
680373	9003176803735	9009016803736	172
680376	9003176803766	9009016803767	172
680377	9003176803773	9009016803774	172
680379	9003176803797	9009016803798	172
680380	9003176803803	9009016803804	172
680383	9003176803834	9009016803835	172
680386	9003176803865	9009016803866	172
680387	9003176803872	9009016803873	172
680388	9003176803889	9009016803880	172
680389	9003176803896	9009016803897	172
680390	9003176803902	9009016803903	172
681095	9003176810955		360
682101	9003176821012	9009016821013	105
682103	9003176821036	9009016821037	105
682104	9003176821043	9009016821044	105
682105	9003176821050	9009016821051	105
682106	9003176821067	9009016821068	105
682107	9003176821074	9009016821075	105
682110	9003176821104	9009016821105	105
682111	9003176821111	9009016821112	105
682112	9003176821128	9009016821129	105
699330	9003176993306	9009016993307	40
699984	9003176999841	9009016999842	171
701439	9003177014390	9009017014391	78
701515	9003177015151	9009017015152	78
701518	9003177015182	9009017015183	78
701934	9003177019340		345
704198	9003177041983	9009017041984	40

Type No.	EAN product	EAN packaging	Page
704617	9003177046179		308
705824	9003177058240		267
705825	9003177058257		267
705826	9003177058264		267
705828	9003177058288		267
705830	9003177058301		267
705831	9003177058318		267
705832	9003177058325		267
705833	9003177058332		267
705834	9003177058349		267
705836	9003177058363		267
705837	9003177058370		267
705839	9003177058394		267
705840	9003177058400		267
705841	9003177058417		267
705842	9003177058424		267
705843	9003177058431		267
705844	9003177058448		267
705845	9003177058455		267
705846	9003177058462		267
705850	9003177058509		267
705851	9003177058516		267
705852	9003177058523		267
705853	9003177058530		267
705854	9003177058547		268
705855	9003177058554		268
705856	9003177058561		268
705857	9003177058578		268
705858	9003177058585		268
705859	9003177058592		268
705860	9003177058608		268
705861	9003177058615		268
705862	9003177058622		268
705863	9003177058639		268
705864	9003177058646		268
705873	9003177058738		268
705874	9003177058745		268
705875	9003177058752		268
705876	9003177058769		268
705877	9003177058776		268

Type No.	EAN product	EAN packaging	Page
705878	9003177058783		268
705879	9003177058790		268
705880	9003177058806		268
705881	9003177058813		268
705882	9003177058820		268
705883	9003177058837		268
705884	9003177058844		268
705885	9003177058851		268
705886	9003177058868		268
705887	9003177058875		268
705888	9003177058882		268
705889	9003177058899		268
705891	9003177058912		268
705892	9003177058929		268
705894	9003177058943		268
705895	9003177058950		268
705896	9003177058967		268
705898	9003177058981		268
705945	9003177059452		266
705946	9003177059469		266
705947	9003177059476		266
705948	9003177059483		266
705959	9003177059599		266
705960	9003177059605		266
705962	9003177059629		266
705965	9003177059650		266
705966	9003177059667		266
705967	9003177059674		266
705968	9003177059681		266
705969	9003177059698		266
705970	9003177059704		266
705972	9003177059728		266
705975	9003177059759		266
705976	9003177059766		266
705977	9003177059773		266
705978	9003177059780		266
705979	9003177059797		266
705980	9003177059803		266
705981	9003177059810		266
705982	9003177059827		266

Type No.	EAN product	EAN packaging	Page
705983	9003177059834		266
705984	9003177059841		267
705985	9003177059858		267
705986	9003177059865		267
705987	9003177059872		267
705988	9003177059889		267
705989	9003177059896	9009017059897	277
705990	9003177059902	9009017059903	277
705991	9003177059919	9009017059910	277
705992	9003177059926	9009017059927	277
705993	9003177059933	9009017059934	277
705994	9003177059940	9009017059941	277
705995	9003177059957	9009017059958	278
705996	9003177059964	9009017059965	278
705997	9003177059971	9009017059972	278
705998	9003177059988	9009017059989	278
705999	9003177059995	9009017059996	278
706000	9003177060007	9009017060008	278
706001	9003177060014	9009017060015	276
706002	9003177060021	9009017060022	276
706003	9003177060038	9009017060039	276
706004	9003177060045	9009017060046	276
706005	9003177060052	9009017060053	276
706006	9003177060069	9009017060060	276
706007	9003177060076	9009017060077	276
706008	9003177060083	9009017060084	276
706009	9003177060090	9009017060091	276
706010	9003177060106	9009017060107	276
706011	9003177060113	9009017060114	276
706012	9003177060120	9009017060121	276
706013	9003177060137	9009017060138	276
706014	9003177060144	9009017060145	276
706015	9003177060151	9009017060152	277
706016	9003177060168	9009017060169	277
706018	9003177060182	9009017060183	277
706020	9003177060205	9009017060206	277
706021	9003177060212	9009017060213	277
706022	9003177060229	9009017060220	277
706023	9003177060236	9009017060237	277
706024	9003177060243	9009017060244	205

Type No.	EAN product	EAN packaging	Page
706025	9003177060250	9009017060251	205
706026	9003177060267	9009017060268	205
706027	9003177060274	9009017060275	205
706028	9003177060281	9009017060282	206
706029	9003177060298	9009017060299	206
706030	9003177060304	9009017060305	206
706031	9003177060311	9009017060312	206
706032	9003177060328	9009017060329	206
706033	9003177060335	9009017060336	206
706034	9003177060342	9009017060343	206
706035	9003177060359	9009017060350	206
706036	9003177060366	9009017060367	206
706037	9003177060373	9009017060374	206
706038	9003177060380	9009017060381	206
706039	9003177060397	9009017060398	206
706047	9003177060472	9009017060473	206
706048	9003177060489	9009017060480	206
706049	9003177060496	9009017060497	205
706050	9003177060502	9009017060503	205
706051	9003177060519	9009017060510	205
706052	9003177060526	9009017060527	205
706053	9003177060533	9009017060534	205
706054	9003177060540	9009017060541	205
706055	9003177060557	9009017060558	205
706056	9003177060564	9009017060565	205
706057	9003177060571	9009017060572	205
706058	9003177060588	9009017060589	205
706059	9003177060595	9009017060596	205
706060	9003177060601	9009017060602	205
706061	9003177060618	9009017060619	205
706063	9003177060632	9009017060633	205
706064	9003177060649	9009017060640	205
706065	9003177060656	9009017060657	205
706066	9003177060663	9009017060664	205
706067	9003177060670	9009017060671	205
706068	9003177060687	9009017060688	200
706069	9003177060694	9009017060695	200
706071	9003177060717	9009017060718	200
706072	9003177060724	9009017060725	200
706073	9003177060731	9009017060732	200

Type No.	EAN product	EAN packaging	Page
706074	9003177060748	9009017060749	200
706075	9003177060755	9009017060756	200
706076	9003177060762	9009017060763	200
706077	9003177060779	9009017060770	200
706078	9003177060786	9009017060787	200
706079	9003177060793	9009017060794	200
706082	9003177060823	9009017060824	200
706084	9003177060847	9009017060848	200
706088	9003177060885	9009017060886	200
706089	9003177060892	9009017060893	200
706090	9003177060908	9009017060909	200
706091	9003177060915	9009017060916	200
706092	9003177060922	9009017060923	200
706107	9003177061073	9009017061074	203
706108	9003177061080	9009017061081	203
706109	9003177061097	9009017061098	203
706110	9003177061103	9009017061104	203
706111	9003177061110	9009017061111	203
706114	9003177061141	9009017061142	203
706116	9003177061165	9009017061166	203
706117	9003177061172	9009017061173	203
706119	9003177061196	9009017061197	204
706120	9003177061202	9009017061203	204
706123	9003177061233	9009017061234	204
706124	9003177061240	9009017061241	204
706125	9003177061257	9009017061258	199
706126	9003177061264	9009017061265	199
706127	9003177061271	9009017061272	199
706128	9003177061288	9009017061289	198
706129	9003177061295	9009017061296	198
706130	9003177061301	9009017061302	198
706135	9003177061356	9009017061357	207
706136	9003177061363	9009017061364	207
706137	9003177061370	9009017061371	207
706138	9003177061387	9009017061388	207
706139	9003177061394	9009017061395	284
706139	9003177061394	9009017061395	207
706141	9003177061417	9009017061418	207
706141	9003177061417	9009017061418	284
706142	9003177061424	9009017061425	207

Type No.	EAN product	EAN packaging	Page
706142	9003177061424	9009017061425	284
706143	9003177061431	9009017061432	207
706143	9003177061431	9009017061432	284
706144	9003177061448	9009017061449	284
706145	9003177061455	9009017061456	284
706146	9003177061462	9009017061463	284
706147	9003177061479	9009017061470	284
706148	9003177061486	9009017061487	284
706149	9003177061493	9009017061494	284
706150	9003177061509	9009017061500	284
706151	9003177061516	9009017061517	284
706152	9003177061523	9009017061524	284
706154	9003177061547	9009017061548	284
706155	9003177061554	9009017061555	284
706157	9003177061578	9009017061579	284
706158	9003177061585	9009017061586	284
706219	9003177062193	9009017062194	285
706221	9003177062216	9009017062217	285
706222	9003177062223	9009017062224	285
706223	9003177062230	9009017062231	285
706224	9003177062247	9009017062248	285
706225	9003177062254	9009017062255	285
706226	9003177062261	9009017062262	285
706227	9003177062278	9009017062279	285
706228	9003177062285	9009017062286	285
706229	9003177062292	9009017062293	285
706244	9003177062445	9009017062446	285
706245	9003177062452	9009017062453	285
706246	9003177062469	9009017062460	285
706248	9003177062483	9009017062484	285
706250	9003177062506	9009017062507	285
706251	9003177062513	9009017062514	285
706255	9003177062551	9009017062552	286
706258	9003177062582	9009017062583	286
706259	9003177062599	9009017062590	286
706260	9003177062605	9009017062606	286
706261	9003177062612	9009017062613	286
706262	9003177062629	9009017062620	286
706264	9003177062643	9009017062644	286
706265	9003177062650	9009017062651	286



Type No.	EAN product	EAN packaging	Page
706266	9003177062667	9009017062668	286
706267	9003177062674	9009017062675	286
706268	9003177062681	9009017062682	286
706269	9003177062698	9009017062699	286
706270	9003177062704	9009017062705	286
706272	9003177062728	9009017062729	286
706273	9003177062735	9009017062736	286
706274	9003177062742	9009017062743	286
706276	9003177062766	9009017062767	286
706277	9003177062773	9009017062774	286
706278	9003177062780	9009017062781	286
706280	9003177062803	9009017062804	286
706281	9003177062810	9009017062811	252
706282	9003177062827	9009017062828	252
706283	9003177062834	9009017062835	252
706284	9003177062841	9009017062842	252
706285	9003177062858	9009017062859	252
706286	9003177062865	9009017062866	252
706290	9003177062902	9009017062903	252
706291	9003177062919	9009017062910	252
706292	9003177062926	9009017062927	252
706293	9003177062933	9009017062934	252
706295	9003177062957	9009017062958	252
706299	9003177062995	9009017062996	252
706300	9003177063008	9009017063009	252
706301	9003177063015	9009017063016	252
706302	9003177063022	9009017063023	252
706303	9003177063039	9009017063030	252
706305	9003177063053	9009017063054	252
706306	9003177063060	9009017063061	252
706307	9003177063077	9009017063078	252
706308	9003177063084	9009017063085	252
706309	9003177063091	9009017063092	252
706310	9003177063107	9009017063108	252
706311	9003177063114	9009017063115	252
706312	9003177063121	9009017063122	252
706313	9003177063138	9009017063139	252
706314	9003177063145	9009017063146	252
706315	9003177063152	9009017063153	252
706316	9003177063169	9009017063160	252

Type No.	EAN product	EAN packaging	Page
706317	9003177063176	9009017063177	253
706318	9003177063183	9009017063184	253
706320	9003177063206	9009017063207	253
706323	9003177063237	9009017063238	253
706324	9003177063244	9009017063245	253
706325	9003177063251	9009017063252	253
706327	9003177063275	9009017063276	253
706328	9003177063282	9009017063283	253
706329	9003177063299	9009017063290	253
706330	9003177063305	9009017063306	253
706331	9003177063312	9009017063313	253
706333	9003177063336	9009017063337	253
706336	9003177063367	9009017063368	253
706337	9003177063374	9009017063375	253
706338	9003177063381	9009017063382	253
706340	9003177063404	9009017063405	253
706341	9003177063411	9009017063412	253
706342	9003177063428	9009017063429	253
706343	9003177063435	9009017063436	253
706344	9003177063442	9009017063443	253
706345	9003177063459	9009017063450	253
706346	9003177063466	9009017063467	253
706347	9003177063473	9009017063474	253
706348	9003177063480	9009017063481	253
706349	9003177063497	9009017063498	255
706350	9003177063503	9009017063504	255
706351	9003177063510	9009017063511	255
706352	9003177063527	9009017063528	255
706353	9003177063534	9009017063535	255
706354	9003177063541	9009017063542	255
706356	9003177063565	9009017063566	255
706361	9003177063619	9009017063610	255
706362	9003177063626	9009017063627	255
706363	9003177063633	9009017063634	255
706364	9003177063640	9009017063641	255
706365	9003177063657	9009017063658	255
706366	9003177063664	9009017063665	255
706367	9003177063671	9009017063672	255
706368	9003177063688	9009017063689	255
706369	9003177063695	9009017063696	255

Type No.	EAN product	EAN packaging	Page	Type No.	EAN product	EAN packaging	Page
706370	9003177063701	9009017063702	255	706422	9003177064227	9009017064228	258
706371	9003177063718	9009017063719	255	706424	9003177064241	9009017064242	258
706372	9003177063725	9009017063726	255	706426	9003177064265	9009017064266	258
706375	9003177063756	9009017063757	255	706428	9003177064289	9009017064280	258
706376	9003177063763	9009017063764	255	706429	9003177064296	9009017064297	258
706377	9003177063770	9009017063771	255	706430	9003177064302	9009017064303	258
706380	9003177063800	9009017063801	255	706432	9003177064326	9009017064327	260
706381	9003177063817	9009017063818	255	706433	9003177064333	9009017064334	260
706383	9003177063831	9009017063832	255	706434	9003177064340	9009017064341	260
706384	9003177063848	9009017063849	255	706435	9003177064357	9009017064358	260
706385	9003177063855	9009017063856	255	706436	9003177064364	9009017064365	260
706386	9003177063862	9009017063863	255	706437	9003177064371	9009017064372	258
706387	9003177063879	9009017063870	255	706438	9003177064388	9009017064389	258
706388	9003177063886	9009017063887	256	706441	9003177064418	9009017064419	258
706393	9003177063930	9009017063931	256	706442	9003177064425	9009017064426	258
706394	9003177063947	9009017063948	256	706443	9003177064432	9009017064433	258
706395	9003177063954	9009017063955	256	706444	9003177064449	9009017064440	258
706397	9003177063978	9009017063979	256	706446	9003177064463	9009017064464	258
706398	9003177063985	9009017063986	256	706447	9003177064470	9009017064471	258
706399	9003177063992	9009017063993	256	706449	9003177064494	9009017064495	259
706401	9003177064012	9009017064013	256	706450	9003177064500	9009017064501	259
706402	9003177064029	9009017064020	256	706451	9003177064517	9009017064518	259
706403	9003177064036	9009017064037	256	706452	9003177064524	9009017064525	259
706404	9003177064043	9009017064044	256	706453	9003177064531	9009017064532	259
706405	9003177064050	9009017064051	256	706454	9003177064548	9009017064549	259
706406	9003177064067	9009017064068	256	706455	9003177064555	9009017064556	259
706407	9003177064074	9009017064075	256	706456	9003177064562	9009017064563	259
706408	9003177064081	9009017064082	256	706457	9003177064579	9009017064570	259
706409	9003177064098	9009017064099	256	706459	9003177064593	9009017064594	259
706410	9003177064104	9009017064105	256	706460	9003177064609	9009017064600	259
706411	9003177064111	9009017064112	256	706461	9003177064616	9009017064617	259
706413	9003177064135	9009017064136	256	706463	9003177064630	9009017064631	259
706414	9003177064142	9009017064143	256	706464	9003177064647	9009017064648	259
706415	9003177064159	9009017064150	256	706465	9003177064654	9009017064655	259
706416	9003177064166	9009017064167	256	706466	9003177064661	9009017064662	259
706417	9003177064173	9009017064174	256	706467	9003177064678	9009017064679	260
706418	9003177064180	9009017064181	256	706469	9003177064692	9009017064693	260
706419	9003177064197	9009017064198	256	706470	9003177064708	9009017064709	260
706420	9003177064203	9009017064204	258	706471	9003177064715	9009017064716	260
706421	9003177064210	9009017064211	258	706472	9003177064722	9009017064723	260

Type No.	EAN product	EAN packaging	Page
706473	9003177064739	9009017064730	258
706474	9003177064746	9009017064747	258
706475	9003177064753	9009017064754	258
706477	9003177064777	9009017064778	258
706478	9003177064784	9009017064785	259
706480	9003177064807	9009017064808	259
706481	9003177064814	9009017064815	259
706482	9003177064821	9009017064822	259
706483	9003177064838	9009017064839	259
706484	9003177064845	9009017064846	259
706489	9003177064890	9009017064891	259
706492	9003177064920	9009017064921	259
706493	9003177064937	9009017064938	259
706494	9003177064944	9009017064945	259
706497	9003177064975	9009017064976	259
706499	9003177064999	9009017064990	259
706500	9003177065002	9009017065003	259
706501	9003177065019	9009017065010	259
706502	9003177065026	9009017065027	259
706503	9003177065033	9009017065034	259
706504	9003177065040	9009017065041	260
706506	9003177065064	9009017065065	260
706507	9003177065071	9009017065072	260
706508	9003177065088	9009017065089	260
706509	9003177065095	9009017065096	260
706511	9003177065118	9009017065119	260
706512	9003177065125	9009017065126	260
706513	9003177065132	9009017065133	260
706514	9003177065149	9009017065140	230
706515	9003177065156	9009017065157	230
706516	9003177065163	9009017065164	230
706517	9003177065170	9009017065171	230
706519	9003177065194	9009017065195	230
706520	9003177065200	9009017065201	230
706521	9003177065217	9009017065218	230
706523	9003177065231	9009017065232	230
706524	9003177065248	9009017065249	230
706525	9003177065255	9009017065256	230
706526	9003177065262	9009017065263	230
706527	9003177065279	9009017065270	230

Type No.	EAN product	EAN packaging	Page
706528	9003177065286	9009017065287	230
706529	9003177065293	9009017065294	230
706530	9003177065309	9009017065300	230
706531	9003177065316	9009017065317	230
706533	9003177065330	9009017065331	230
706534	9003177065347	9009017065348	230
706535	9003177065354	9009017065355	230
706536	9003177065361	9009017065362	230
706537	9003177065378	9009017065379	230
706538	9003177065385	9009017065386	230
706539	9003177065392	9009017065393	230
706540	9003177065408	9009017065409	230
706541	9003177065415	9009017065416	230
706542	9003177065422	9009017065423	230
706543	9003177065439	9009017065430	230
706544	9003177065446	9009017065447	230
706545	9003177065453	9009017065454	231
706546	9003177065460	9009017065461	231
706547	9003177065477	9009017065478	231
706548	9003177065484	9009017065485	231
706550	9003177065507	9009017065508	231
706551	9003177065514	9009017065515	231
706552	9003177065521	9009017065522	231
706553	9003177065538	9009017065539	231
706555	9003177065552	9009017065553	231
706557	9003177065576	9009017065577	231
706558	9003177065583	9009017065584	231
706559	9003177065590	9009017065591	231
706560	9003177065606	9009017065607	231
706561	9003177065613	9009017065614	231
706562	9003177065620	9009017065621	231
706563	9003177065637	9009017065638	231
706564	9003177065644	9009017065645	231
706565	9003177065651	9009017065652	231
706566	9003177065668	9009017065669	231
706567	9003177065675	9009017065676	231
706568	9003177065682	9009017065683	231
706569	9003177065699	9009017065690	231
706570	9003177065705	9009017065706	231
706571	9003177065712	9009017065713	231

Type No.	EAN product	EAN packaging	Page
706573	9003177065736	9009017065737	231
706574	9003177065743	9009017065744	231
706575	9003177065750	9009017065751	231
706576	9003177065767	9009017065768	231
706577	9003177065774	9009017065775	231
706578	9003177065781	9009017065782	231
707005	9003177070051	9009017070052	179
707007	9003177070075	9009017070076	179
707008	9003177070082	9009017070083	179
707010	9003177070105	9009017070106	179
707011	9003177070112	9009017070113	179
707012	9003177070129	9009017070120	179
707013	9003177070136	9009017070137	179
707014	9003177070143	9009017070144	179
707015	9003177070150	9009017070151	179
707016	9003177070167	9009017070168	179
707017	9003177070174	9009017070175	179
707018	9003177070181	9009017070182	179
707153	9003177071539	9009017071530	179
707155	9003177071553	9009017071554	179
707156	9003177071560	9009017071561	179
707158	9003177071584	9009017071585	179
707159	9003177071591	9009017071592	179
707160	9003177071607	9009017071608	179
707161	9003177071614	9009017071615	179
707163	9003177071638	9009017071639	179
707165	9003177071652	9009017071653	179
707166	9003177071669	9009017071660	179
707167	9003177071676	9009017071677	179
707168	9003177071683	9009017071684	179
707230	9003177072307		362
707365	9003177073656		311
707824	9003177078248		352
707827	9003177078279		352
707831	9003177078316		352
707834	9003177078347		352
709989	9003177099892	9009017099893	206
709991	9003177099915	9009017099916	206
709992	9003177099922	9009017099923	206
709993	9003177099939	9009017099930	206

Type No.	EAN product	EAN packaging	Page
709994	9003177099946	9009017099947	206
709995	9003177099953	9009017099954	207
709997	9003177099977	9009017099978	207
709998	9003177099984	9009017099985	207
709999	9003177099991	9009017099992	207
710002	9003177100024	9009017100025	207
710005	9003177100055	9009017100056	207
710006	9003177100062	9009017100063	207
710007	9003177100079	9009017100070	287
710008	9003177100086		287
710009	9003177100093		287
710011	9003177100116	9009017100117	232
710012	9003177100123	9009017100124	232
710013	9003177100130	9009017100131	232
710014	9003177100147	9009017100148	232
710015	9003177100154	9009017100155	232
710016	9003177100161	9009017100162	232
710017	9003177100178	9009017100179	232
710018	9003177100185	9009017100186	232
710022	9003177100222	9009017100223	232
710023	9003177100239	9009017100230	232
710025	9003177100253	9009017100254	232
710026	9003177100260	9009017100261	232
711834	9003177118340	9009017118341	40
712259	9003177122590	9009017122591	198
712268	9003177122682	9009017122683	198
712269	9003177122699	9009017122690	198
719788	9003177197888	9009017197889	181
719793	9003177197932	9009017197933	182
719794	9003177197949	9009017197940	182
719796	9003177197963	9009017197964	182
719797	9003177197970	9009017197971	178
719798	9003177197987	9009017197988	178
719799	9003177197994	9009017197995	178
719800	9003177198007	9009017198008	178
719840	9003177198403	9009017198404	178
719841	9003177198410	9009017198411	178
719846	9003177198465	9009017198466	178
719847	9003177198472	9009017198473	178
722408	9003177224089	9009017224080	58



Type No.	EAN product	EAN packaging	Page
722981	9003177229817	9009017229818	52
724257	9003177242571	9009017242572	276
724264	9003177242649	9009017242640	276
724267	9003177242670	9009017242671	276
724268	9003177242687	9009017242688	276
724271	9003177242717	9009017242718	276
724272	9003177242724	9009017242725	276
724273	9003177242731	9009017242732	276
724275	9003177242755	9009017242756	276
724276	9003177242762	9009017242763	277
724281	9003177242816	9009017242817	277
724283	9003177242830	9009017242831	277
724284	9003177242847	9009017242848	277
724285	9003177242854	9009017242855	277
728528	9003177285288	9009017285289	171
728649	9003177286490	9009017286491	182
728650	9003177286506	9009017286507	182
728657	9003177286575	9009017286576	182
728659	9003177286599	9009017286590	182
728661	9003177286612	9009017286613	182
729764	9003177297649	9009017297640	174
730559	9003177305597	9009017305598	174
730560	9003177305603	9009017305604	174
732088	9003177320880	9009017320881	45
734378	9003177343780	9009017343781	72
734693	9003177346934	9009017346935	82
734828	9003177348280	9009017348281	108
736088	9003177360886		326
736095	9003177360954		328
736102	9003177361029		326
736105	9003177361050		328
736309	9003177363092		334
736311	9003177363115		334
736313	9003177363139		334
739982	9003177399824	9009017399825	24
741230	9003177412301	9009017412302	187
741285	9003177412851	9009017412852	187
741291	9003177412912	9009017412913	187
741347	9003177413476		187
741348	9003177413483		187

Type No.	EAN product	EAN packaging	Page
741349	9003177413490		187
742148	9003177421488	9009017421489	186
742153	9003177421532	9009017421533	186
742154	9003177421549	9009017421540	186
742155	9003177421556	9009017421557	186
742157	9003177421570	9009017421571	186
742158	9003177421587	9009017421588	186
742167	9003177421679	9009017421670	175
742168	9003177421686	9009017421687	175
742375	9003177423758	9009017423759	186
742378	9003177423789	9009017423780	186
742379	9003177423796	9009017423797	186
742380	9003177423802	9009017423803	186
742381	9003177423819	9009017423810	186
742382	9003177423826	9009017423827	186
742384	9003177423840	9009017423841	186
742385	9003177423857	9009017423858	186
743938	9003177439384	9009017439385	33
743942	9003177439421	9009017439422	33
743944	9003177439445	9009017439446	33
743946	9003177439469	9009017439460	31
743947	9003177439476	9009017439477	31
757089	9003177570896	9009017570897	33
759007	9003177590078		360
765657	9003177656576		118
765996	9003177659966		118
766046	9003177660467		118
766050	9003177660504		118
766051	9003177660511		118
766062	9003177660627		118
766068	9003177660689		118
766072	9003177660726		118
766091	9003177660917		119
766092	9003177660924		119
766099	9003177660993		120
766100	9003177661006		120
766108	9003177661082		120
766111	9003177661112		120
766112	9003177661129		120
766113	9003177661136		120

Type No.	EAN product	EAN packaging	Page
766115	9003177661150		120
766116	9003177661167		120
766117	9003177661174		121
766119	9003177661198		121
766120	9003177661204		120
766121	9003177661211		121
766126	9003177661266		119
766127	9003177661273		119
766130	9003177661303		120
766131	9003177661310		120
766133	9003177661334		120
766134	9003177661341		120
766139	9003177661396		119
766140	9003177661402		119
766145	9003177661457		119
766147	9003177661471		119
766150	9003177661501		119
766154	9003177661549		119
766155	9003177661556		118
766156	9003177661563		118
766160	9003177661600		119
766927	9003177669279		118
766929	9003177669293		119
766930	9003177669309		120
766932	9003177669323		118
766934	9003177669347		118
766935	9003177669354		121
766936	9003177669361		118
766937	9003177669378		119
766939	9003177669392		119
766942	9003177669422		119
766944	9003177669446		120
766945	9003177669453		120
766949	9003177669491		120
768710	9003177687105		120
768712	9003177687129		120
768715	9003177687150		122
768717	9003177687174		122
768718	9003177687181		121
768721	9003177687211		121

Type No.	EAN product	EAN packaging	Page
768747	9003177687471		120
768750	9003177687501		120
768752	9003177687525		120
768754	9003177687549		120
768821	9003177688218		118
768824	9003177688249		118
768828	9003177688287		118
768832	9003177688324		118
768833	9003177688331		118
768834	9003177688348		118
768835	9003177688355		118
768838	9003177688386		118
768841	9003177688416		118
768843	9003177688430		119
768845	9003177688454		121
768846	9003177688461		119
768847	9003177688478		119
768848	9003177688485		121
768873	9003177688737		119
768874	9003177688744		119
768877	9003177688775		120
768878	9003177688782		120
768880	9003177688805		120
768881	9003177688812		120
768884	9003177688843		121
768885	9003177688850		121
768887	9003177688874		120
768888	9003177688881		120
768891	9003177688911		120
768894	9003177688942		118
768896	9003177688966		121
768898	9003177688980		118
768912	9003177689123		119
768913	9003177689130		119
768916	9003177689161		119
768918	9003177689185		119
768919	9003177689192		119
768924	9003177689246		119
768926	9003177689260		119
768929	9003177689291		119

Type No.	EAN product	EAN packaging	Page
768941	9003177689413		119
768942	9003177689420		119
768944	9003177689444		119
768948	9003177689482		119
768949	9003177689499		119
768951	9003177689512		119
769680	9003177696800		118
769683	9003177696831		118
773268	9003177732683	9009017732684	22
773269	9003177732690	9009017732691	22
779426	9003177794261	9009017794262	52
779428	9003177794285	9009017794286	52
780935	9003177809354	9009017809355	52
780938	9003177809385	9009017809386	52
785333	9003177853333	9009017853334	27
785339	9003177853395	9009017853396	27
788700	9003177887000		60
793077	9003177930775	9009017930776	53
795077	9003177950773	9009017950774	171
800035	9003178000354	9009018000355	53
801348	9003178013484		120
801349	9003178013491		120
801351	9003178013514		118
801354	9003178013545		118
801355	9003178013552		118
801365	9003178013651		119
801524	9003178015242		121
801527	9003178015273		121
801528	9003178015280		121
801529	9003178015297		121
801530	9003178015303		121
801531	9003178015310		121
803404	9003178034045		40
803404	9003178034045		99
803833	9003178038333	9009018038334	106
806824	9003178068248		121
806826	9003178068262		121
816831	9003178168313	9009018168314	242
816833	9003178168337	9009018168338	242
816843	9003178168436	9009018168437	242

Type No.	EAN product	EAN packaging	Page
816846	9003178168467	9009018168468	243
816847	9003178168474	9009018168475	243
816854	9003178168542	9009018168543	243
816855	9003178168559	9009018168550	243
816871	9003178168719	9009018168710	243
816872	9003178168726	9009018168727	243
816873	9003178168733	9009018168734	243
816874	9003178168740	9009018168741	243
816875	9003178168757	9009018168758	243
816880	9003178168801	9009018168802	243
816893	9003178168931	9009018168932	243
816905	9003178169051	9009018169052	243
816906	9003178169068	9009018169069	243
816907	9003178169075	9009018169076	243
816908	9003178169082	9009018169083	243
816909	9003178169099	9009018169090	244
816911	9003178169112	9009018169113	244
816912	9003178169129	9009018169120	244
816913	9003178169136	9009018169137	244
816914	9003178169143	9009018169144	244
816915	9003178169150	9009018169151	244
816916	9003178169167	9009018169168	244
816918	9003178169181	9009018169182	244
816919	9003178169198	9009018169199	244
816920	9003178169204	9009018169205	244
816921	9003178169211	9009018169212	244
816922	9003178169228	9009018169229	244
816923	9003178169235	9009018169236	244
816924	9003178169242	9009018169243	244
816925	9003178169259	9009018169250	244
816926	9003178169266	9009018169267	244
816927	9003178169273	9009018169274	244
816928	9003178169280	9009018169281	244
816931	9003178169310	9009018169311	244
816933	9003178169334	9009018169335	244
816934	9003178169341	9009018169342	244
816939	9003178169396	9009018169397	244
816940	9003178169402	9009018169403	245
816941	9003178169419	9009018169410	245
816942	9003178169426	9009018169427	245

Type No.	EAN product	EAN packaging	Page
816943	9003178169433	9009018169434	245
816949	9003178169495	9009018169496	245
816950	9003178169501	9009018169502	245
816951	9003178169518	9009018169519	245
816952	9003178169525	9009018169526	245
816953	9003178169532	9009018169533	245
816954	9003178169549	9009018169540	245
816955	9003178169556	9009018169557	245
816956	9003178169563	9009018169564	245
816957	9003178169570	9009018169571	245
816958	9003178169587	9009018169588	245
816959	9003178169594	9009018169595	245
816960	9003178169600	9009018169601	245
816961	9003178169617	9009018169618	245
816962	9003178169624	9009018169625	245
816963	9003178169631	9009018169632	245
816964	9003178169648	9009018169649	245
816965	9003178169655	9009018169656	245
816966	9003178169662	9009018169663	245
816967	9003178169679	9009018169670	245
816968	9003178169686	9009018169687	245
816969	9003178169693	9009018169694	245
816971	9003178169716	9009018169717	246
816972	9003178169723	9009018169724	246
816973	9003178169730	9009018169731	246
816974	9003178169747	9009018169748	246
816976	9003178169761	9009018169762	246
816977	9003178169778	9009018169779	246
816978	9003178169785	9009018169786	246
816981	9003178169815	9009018169816	246
816982	9003178169822	9009018169823	246
816983	9003178169839	9009018169830	246
816984	9003178169846	9009018169847	246
816985	9003178169853	9009018169854	246
816986	9003178169860	9009018169861	246
816987	9003178169877	9009018169878	246
816989	9003178169891	9009018169892	246
816990	9003178169907	9009018169908	246
816991	9003178169914	9009018169915	246
816992	9003178169921	9009018169922	246

Type No.	EAN product	EAN packaging	Page
816993	9003178169938	9009018169939	246
817001	9003178170019	9009018170010	246
817003	9003178170033	9009018170034	246
817011	9003178170118	9009018170119	245
817012	9003178170125	9009018170126	245
817603	9003178176035		345
817606	9003178176066		345
817607	9003178176073		345
817672	9003178176721	9009018176722	171
817935	9003178179357	9009018179358	171
822718	9003178227188		123
822725	9003178227256		122
822728	9003178227287		123
824385	9003178243850	9009018243851	180
828013	9003178280138		320
828192	9003178281920	9009018281921	108
829026	9003178290267		137
829292	9003178292926		134
829293	9003178292933		134
829306	9003178293060		136
829330	9003178293305		136
829562	9003178295620	9009018295621	52
834839	9003178348395	9009018348396	60
837619	9003178376190		118
840247	9003178402479	9009018402470	24
843037	9003178430373	9009018430374	70
843806	9003178438065	9009018438066	179
846344	9003178463449	9009018463440	175
846441	9003178464415		40
846441	9003178464415		99
846442	9003178464422		40
846442	9003178464422		99
847917	9003178479174	9009018479175	180
847921	9003178479211	9009018479212	180
847923	9003178479235	9009018479236	181
847924	9003178479242	9009018479243	180
847925	9003178479259	9009018479250	180
847926	9003178479266	9009018479267	181
847927	9003178479273	9009018479274	180
847928	9003178479280	9009018479281	180



Type No.	EAN product	EAN packaging	Page
847929	9003178479297	9009018479298	181
848563	9003178485632	9009018485633	244
850011	9003178500113		352
850026	9003178500267		352
855818	9003178558183	9009018558184	30
858531	9003178585318		60
863284	9003178632845	9009018632846	59
872338	9003178723383	9009018723384	28
872339	9003178723390	9009018723391	28
872340	9003178723406	9009018723407	28
872341	9003178723413	9009018723414	28
872342	9003178723420	9009018723421	28
872343	9003178723437	9009018723438	28
872344	9003178723444	9009018723445	28
872346	9003178723468	9009018723469	28
872347	9003178723475	9009018723476	28
872348	9003178723482	9009018723483	28
872349	9003178723499	9009018723490	28
872350	9003178723505	9009018723506	28
872351	9003178723512	9009018723513	28
872352	9003178723529	9009018723520	28
886353	9003178863539	9009018863530	171
886805	9003178868053	9009018868054	243
889232	9003178892324		362
890608	9003178906083		137
890618	9003178906182		137
890623	9003178906236		137
890626	9003178906267		137
890635	9003178906359		137
890649	9003178906496	9009018906497	143
890650	9003178906502	9009018906503	143
890652	9003178906526	9009018906527	144
890653	9003178906533	9009018906534	144
890654	9003178906540	9009018906541	144
890655	9003178906557	9009018906558	144
890658	9003178906588	9009018906589	144
890707	9003178907073	9009018907074	144
890708	9003178907080	9009018907081	144
890709	9003178907097	9009018907098	144
890717	9003178907172	9009018907173	144

Type No.	EAN product	EAN packaging	Page
890718	9003178907189	9009018907180	144
890719	9003178907196	9009018907197	143
890721	9003178907219	9009018907210	143
890722	9003178907226	9009018907227	143
890723	9003178907233	9009018907234	143
890753	9003178907530	9009018907531	145
890756	9003178907561	9009018907562	145
890757	9003178907578	9009018907579	146
890758	9003178907585	9009018907586	146
890761	9003178907615	9009018907616	146
890762	9003178907622	9009018907623	146
890763	9003178907639	9009018907630	145
890764	9003178907646	9009018907647	145
890765	9003178907653	9009018907654	145
890766	9003178907660	9009018907661	145
890768	9003178907684	9009018907685	146
890769	9003178907691	9009018907692	146
890771	9003178907714	9009018907715	146
890772	9003178907721	9009018907722	146
890774	9003178907745	9009018907746	145
890776	9003178907769	9009018907760	145
890777	9003178907776	9009018907777	145
890778	9003178907783	9009018907784	145
890779	9003178907790	9009018907791	146
890780	9003178907806	9009018907807	146
890810	9003178908100	9009018908101	147
890811	9003178908117	9009018908118	148
890812	9003178908124	9009018908125	148
890813	9003178908131	9009018908132	148
890814	9003178908148	9009018908149	148
890815	9003178908155	9009018908156	148
890817	9003178908179	9009018908170	148
890819	9003178908193	9009018908194	148
890820	9003178908209	9009018908200	148
890821	9003178908216	9009018908217	148
890822	9003178908223	9009018908224	148
890823	9003178908230	9009018908231	148
890827	9003178908278	9009018908279	148
890828	9003178908285	9009018908286	148
890831	9003178908315	9009018908316	148

Type No.	EAN product	EAN packaging	Page
890832	9003178908322	9009018908323	148
890835	9003178908353	9009018908354	148
890840	9003178908407	9009018908408	147
890841	9003178908414	9009018908415	147
890842	9003178908421	9009018908422	147
890843	9003178908438	9009018908439	147
890844	9003178908445	9009018908446	147
890845	9003178908452	9009018908453	147
890846	9003178908469	9009018908460	147
890847	9003178908476	9009018908477	147
890848	9003178908483	9009018908484	147
890849	9003178908490	9009018908491	147
890851	9003178908513		135
890852	9003178908520		135
890853	9003178908537		135
890854	9003178908544		135
890855	9003178908551		135
890856	9003178908568		135
890858	9003178908582		135
890859	9003178908599		135
890860	9003178908605		135
890862	9003178908629		135
890863	9003178908636		135
890864	9003178908643		135
890865	9003178908650		135
890866	9003178908667		135
890868	9003178908681		135
891126	9003178911261	9009018911262	112
894085	9003178940858		137
894258	9003178942586		346
894595	9003178945952		136
894598	9003178945983		136
894602	9003178946027		136
894770	9003178947703		154
895498	9003178954985	9009018954986	160
895521	9003178955210	9009018955211	148
895576	9003178955760	9009018955761	160
895577	9003178955777	9009018955778	160
895578	9003178955784	9009018955785	160
895579	9003178955791	9009018955792	160

Type No.	EAN product	EAN packaging	Page
895580	9003178955807	9009018955808	160
895581	9003178955814	9009018955815	161
895669	9003178956699	9009018956690	93
895670	9003178956705	9009018956706	93
895671	9003178956712	9009018956713	93
895676	9003178956767	9009018956768	93
895677	9003178956774	9009018956775	93
895678	9003178956781	9009018956782	93
895679	9003178956798	9009018956799	93
896109	9003178961099		154
896110	9003178961105		155
896111	9003178961112		154
896113	9003178961136		155
896115	9003178961150		154
896116	9003178961167		155
896119	9003178961198		155
896121	9003178961211		154
896122	9003178961228		155
896123	9003178961235		154
896124	9003178961242		155
896157	9003178961570		134
896158	9003178961587		134
896160	9003178961600		134
896161	9003178961617		134
896162	9003178961624		134
896163	9003178961631		134
896164	9003178961648		134
896165	9003178961655		134
896167	9003178961679		135
896169	9003178961693		135
896170	9003178961709		135
896171	9003178961716		135
896172	9003178961723		135
896173	9003178961730		135
896174	9003178961747		135
896175	9003178961754		135
896207	9003178962072	9009018962073	160
896209	9003178962096	9009018962097	160
896217	9003178962171	9009018962172	161
896219	9003178962195	9009018962196	161

Type No.	EAN product	EAN packaging	Page
896220	9003178962201	9009018962202	161
896223	9003178962232	9009018962233	160
896224	9003178962249	9009018962240	160
896237	9003178962379		154
896238	9003178962386		154
896239	9003178962393		154
896241	9003178962416		154
896243	9003178962430		154
896244	9003178962447		154
896245	9003178962454		154
896246	9003178962461		154
896247	9003178962478		154
896250	9003178962508		134
896252	9003178962522		134
896253	9003178962539		134
896255	9003178962553		134
896260	9003178962607		136
896289	9003178962898		135
896290	9003178962904		135
896291	9003178962911		135
896292	9003178962928		135
896293	9003178962935		135
896294	9003178962942		136
896379	9003178963796	9009018963797	171
896630	9003178966308		154
896943	9003178969439		136
897078	9003178970787	9009018970788	244
897357	9003178973573	9009018973574	144
898012	9003178980120	9009018980121	193
898014	9003178980144	9009018980145	193
898017	9003178980175	9009018980176	193
898018	9003178980182	9009018980183	193
898044	9003178980441	9009018980442	235
898048	9003178980489	9009018980480	235
898051	9003178980519	9009018980510	235
898839	9003178988393		155
899271	9003178992710		351
899272	9003178992727		351
899851	9003178998514	9009018998515	160
902665	9003179026650		120

Type No.	EAN product	EAN packaging	Page
902668	9003179026681		120
902700	9003179027008		118
902724	9003179027244		119
902732	9003179027329		118
902737	9003179027374		119
902747	9003179027473		119
903337	9003179033375	9009019033376	148
903339	9003179033399	9009019033390	148
903340	9003179033405	9009019033406	144
903343	9003179033436	9009019033437	144
903350	9003179033504	9009019033505	144
903357	9003179033573	9009019033574	143
903359	9003179033597	9009019033598	145
903363	9003179033634	9009019033635	149
903404	9003179034044		154
903406	9003179034068		137
903407	9003179034075		154
903408	9003179034082		154
903409	9003179034099		154
903411	9003179034112		154
903413	9003179034136		154
903421	9003179034211	9009019034212	147
903422	9003179034228	9009019034229	147
903423	9003179034235	9009019034236	147
903424	9003179034242	9009019034243	147
903425	9003179034259	9009019034250	147
903427	9003179034273	9009019034274	145
903428	9003179034280	9009019034281	145
903429	9003179034297	9009019034298	143
903430	9003179034303	9009019034304	143
903431	9003179034310	9009019034311	143
903432	9003179034327	9009019034328	143
903434	9003179034341	9009019034342	161
903877	9003179038776	9009019038777	146
903878	9003179038783	9009019038784	146
904019	9003179040199	9009019040190	30
905335	9003179053359		235
905336	9003179053366		235
905337	9003179053373		235
907800	9003179078000	9009019078001	28

Type No.	EAN product	EAN packaging	Page
908220	9003179082205	9009019082206	88
908221	9003179082212	9009019082213	88
908223	9003179082236	9009019082237	88
908224	9003179082243	9009019082244	88
908225	9003179082250	9009019082251	87
908226	9003179082267	9009019082268	87
908227	9003179082274	9009019082275	87
908229	9003179082298	9009019082299	87
908230	9003179082304	9009019082305	87
908231	9003179082311	9009019082312	87
908233	9003179082335	9009019082336	88
908263	9003179082632	9009019082633	149
908264	9003179082649	9009019082640	149
908265	9003179082656	9009019082657	149
908708	9003179087088	9009019087089	240
908710	9003179087101	9009019087102	240
908711	9003179087118	9009019087119	240
908712	9003179087125	9009019087126	240
908715	9003179087156	9009019087157	240
908717	9003179087170	9009019087171	240
908775	9003179087750	9009019087751	240
908779	9003179087798	9009019087799	240
908780	9003179087804	9009019087805	241
908784	9003179087842	9009019087843	240
908794	9003179087941	9009019087942	240
908795	9003179087958	9009019087959	240
908796	9003179087965	9009019087966	240
908821	9003179088214	9009019088215	241
908823	9003179088238	9009019088239	241
908825	9003179088252	9009019088253	241
908826	9003179088269	9009019088260	241
908854	9003179088542	9009019088543	240
908862	9003179088627	9009019088628	240
908871	9003179088719	9009019088710	241
908872	9003179088726	9009019088727	241
909220	9003179092204		360
909362	9003179093621	9009019093622	244
909368	9003179093683	9009019093684	245
909383	9003179093836	9009019093837	242
909385	9003179093850	9009019093851	242

Type No.	EAN product	EAN packaging	Page
909388	9003179093881	9009019093882	243
909390	9003179093904	9009019093905	243
909393	9003179093935	9009019093936	243
909396	9003179093966	9009019093967	243
909397	9003179093973	9009019093974	243
909398	9003179093980	9009019093981	243
909400	9003179094000	9009019094001	243
909404	9003179094048	9009019094049	243
909405	9003179094055	9009019094056	243
910558	9003179105584	9009019105585	243
910572	9003179105720	9009019105721	245
910574	9003179105744	9009019105745	245
910579	9003179105799	9009019105790	245
910587	9003179105874	9009019105875	245
910707	9003179107076	9009019107077	245
910718	9003179107182	9009019107183	246
910720	9003179107205	9009019107206	246
910722	9003179107229	9009019107220	246
910766	9003179107663		119
910834	9003179108349		119
910853	9003179108530	9009019108531	241
910864	9003179108646	9009019108647	241
910890	9003179108905	9009019108906	241
910902	9003179109025	9009019109026	241
912603	9003179126039	9009019126030	28
913338	9003179133389	9009019133380	77
915555	9003179155558		154
915557	9003179155572		154
915573	9003179155732	9009019155733	246
916720	9003179167209		155
920351	9003179203518	9009019203519	22
920353	9003179203532	9009019203533	22
920436	9003179204362		154
920824	9003179208247		154
923064	9003179230644		154
927369	9003179273696		154
929017	9003179290174	9009019290175	79
929018	9003179290181	9009019290182	79
929019	9003179290198	9009019290199	79
929020	9003179290204	9009019290205	79



Type No.	EAN product	EAN packaging	Page
929849	9003179298491		155
929885	9003179298859	9009019298850	30
929886	9003179298866	9009019298867	30
929887	9003179298873	9009019298874	30
929889	9003179298897	9009019298898	30
934433	9003179344334	9009019344335	144
935157	9003179351578		155
936422	9003179364226	9009019364227	143
938384	9003179383845		154
938642	9003179386426		136
938646	9003179386464		136
938680	9003179386808		137
938999	9003179389991	9009019389992	112
939107	9003179391079	9009019391070	243
939696	9003179396968		155
939697	9003179396975		155
939968	9003179399686	9009019399687	143
941497	9003179414976	9009019414977	108
942005	9003179420052		137
943167	9003179431676	9009019431677	235
943168	9003179431683	9009019431684	235
943863	9003179438637		154
943976	9003179439764		137
947205	9003179472051		137
948218	9003179482180	9009019482181	88
959241	9003179592414	9009019592415	243
960324	9003179603240		137
10983845	9003170025805		353
10983964	9003170025775		353
10986189	9003170025836		353
10986190	9003170025850		353
34019872	9003170002417	9009010001688	26
34019874	9003170002424	9009010001701	71
34019876	9003170002448	9009010001718	71
34019877	9003170002455	9009010001725	71
34019878	9003170002462	9009010001732	71
34019879	9003170002479	9009010001756	71
34019880	9003170002493	9009010001787	26
34019881	9003170002516	9009010001800	27
34019882	9003170002523	9009010001817	27

Type No.	EAN product	EAN packaging	Page
34019883	9003170002530	9009010001831	27
34019884	9003170002578	9009010001848	27
34022392	9003170010542		121
34022430	9003170010580		123
34022958	9003170010528	9009010010840	25
34022959	9003170010382	9009010010826	25
34023527	9003170013918	9009010015975	182
34023528	9003170013932	9009010016026	182
34023529	9003170013949	9009010016033	182
34023530	9003170013956	9009010016095	182
34023778	9003170013000		133
34023780	9003170013048		133
34023812	9003170013062		134
34023813	9003170013208		134
34023817	9003170013215		133
34023818	9003170013246		134
34023819	9003170013253		133
34023822	9003170014434		134
34023823	9003170013260		133
34023824	9003170013352		133
34023825	9003170013369		134
34023826	9003170013406		134
34023827	9003170013413		133
34023828	9003170013437		133
34023829	9003170013444		134
34023830	9003170013451		134
34024028	9003170010603		299
34036456	9003170067386	9009010016194	285
34036457	9003170072342	9009010016217	285
34036458	9003170075053	9009010016255	285
34036459	9003170097864	9009010016293	285
34036460	9003170104463	9009010016309	285
34036501	9003170108188	9009010016316	285
34036502	9003170119009	9009010016323	285
34036503	9003170119603	9009010016347	285
34036504	9003170170123	9009010016422	285
34036505	9003170211536	9009010016460	285
34038259	9003170022194	9009010024595	146
34038260	9003170022255	9009010024618	146
34040606	9003176744717	9009010022638	22

Type No.	EAN product	EAN packaging	Page
34040607	9003176744731	9009010022683	22
34040608	9003177732683	9009010022706	22
34040609	9003177732690	9009010022713	22
34042238	9003170018999	9009010020986	26
34042239	9003170019002	9009010021006	26
34042240	9003170019026	9009010021013	26
34042515	9003170022910		136
34042517	9003170022927		136
34042518	9003170022934		135
34042519	9003170022941		135
34042520	9003170022958		136
34042522	9003170022965		137
34042524	9003170022972		137
34042525	9003170022989		137
34042526	9003170022996		137
34042527	9003170023016		137
34042528	9003170023023		137
34042756	9003170019132	9009010021075	30
34042757	9003170019156	9009010021082	30
34042794	9003170022279	9009010024632	147
34042874	9003170019293	9009010021099	75
34042875	9003170019330	9009010021105	75
34043171	9003170022286	9009010024649	145
34043172	9003170022293	9009010024694	146
34043173	9003170022323	9009010024700	146
34043174	9003170022354	9009010024717	146
34043175	9003170022378	9009010024724	146
34043177	9003170022392	9009010024748	147
34043178	9003170022897	9009010024779	147
34043179	9003170022415	9009010024793	143
34043180	9003170022422	9009010024823	143
34043181	9003170022439	9009010024847	143
34043471	9003170019378	9009010021853	174
34043472	9003170019385	9009010021884	174
34043473	9003170019408	9009010021907	174
34043474	9003170019422	9009010021921	174
34043475	9003170019491	9009010021938	174
34043476	9003170019514	9009010021945	174
34043477	9003170019521	9009010021952	174
34043478	9003170019545	9009010021969	174

Type No.	EAN product	EAN packaging	Page
34043479	9003170019552	9009010021976	174
34043480	9003170019569	9009010021983	174
34043481	9003170019651	9009010021990	174
34043482	9003170019705	9009010022003	174
34043514	9003170019736	9009010022058	176
34043515	9003170019750	9009010022065	176
34043516	9003170019767	9009010022072	176
34043517	9003170019774	9009010022089	177
34043520	9003170022446	9009010024878	143
34043541	9003170022460	9009010024892	143
34043542	9003170022538	9009010024908	143
34043543	9003170022545	9009010024915	143
34043544	9003170022576	9009010024922	143
34043545	9003170022866	9009010024946	143
34043546	9003170022620	9009010024960	147
34043547	9003170022637	9009010025004	145
34043548	9003170022682	9009010025035	145
34043549	9003170022705	9009010025059	145
34043550	9003170022712	9009010025066	145
34043552	9003170022729	9009010025073	145
34043554	9003170022743	9009010025110	147
34043555	9003170022750	9009010025202	147
34043557	9003170022774	9009010025226	147
34043559	9003170022781	9009010025288	148
34043560	9003170022804	9009010025387	148
34043572	9003170022903	9009010025448	149
34043575	9003170023030		155
34043576	9003170023047		155
34043577	9003170023061		155
34043578	9003170023108		155
34043579	9003170023122		155
34046119	9003170020282	9009010022409	72
34046120	9003170020299	9009010022416	72
34046131	9003170020367	9009010022423	72
34046132	9003170020374	9009010022430	72
34046133	9003170020381	9009010022447	73
34046134	9003170020404	9009010022461	73
34046135	9003170020411	9009010022539	73
34046136	9003170020442	9009010022546	73
34046137	9003170020459	9009010022577	73

Type No.	EAN product	EAN packaging	Page
34047714	9003170031639	9009010022935	212
34047715	9003170031646	9009010022942	212
34047716	9003170031653	9009010022959	212
34047720	9003170031660	9009010022966	212
34047722	9003170031677	9009010022973	212
34047724	9003170031714	9009010022980	212
34047727	9003170031721	9009010022997	212
34047730	9003170031738	9009010023017	212
34047732	9003170031745	9009010023024	212
34047733	9003170031752	9009010023031	212
34047734	9003170031769	9009010023048	213
34047735	9003170031783	9009010023062	213
34047736	9003170031806	9009010023109	213
34047755	9003170031813	9009010023123	213
34047757	9003170031820	9009010023130	213
34047759	9003170021210	9009010023147	254
34047771	9003170021234	9009010023161	254
34047772	9003170021241	9009010023192	254
34047773	9003170032049	9009010023222	254
34047774	9003170021326	9009010023239	254
34047775	9003170032056	9009010023246	254
34047776	9003170021371	9009010023253	254
34047777	9003170021388	9009010023260	254
34047779	9003170021395	9009010023314	254
34047780	9003170021418	9009010023321	254
34047784	9003170021463	9009010023338	254
34047785	9003170021470	9009010023345	254
34047789	9003170021609	9009010023444	254
34047790	9003170021616	9009010023468	254
34047792	9003170021623	9009010023475	254
34047794	9003170021647	9009010023482	254
34047796	9003170021661	9009010023529	254
34047797	9003170021685	9009010023536	254
34047798	9003170021708	9009010023567	254
34047799	9003170021715	9009010023581	254
34047800	9003170021746	9009010023598	254
34047814	9003170021883	9009010023635	254
34047815	9003170021906	9009010023642	254
34049667	9003170021920	9009010023659	254
34049705	9003170021968	9009010023703	261

Type No.	EAN product	EAN packaging	Page
34049706	9003170021975	9009010023710	261
34049709	9003170021982	9009010023734	261
34049731	9003170021999	9009010023758	261
34049732	9003170022002	9009010023772	261
34049734	9003170022057	9009010023789	261
34049736	9003170022064	9009010023796	261
34049737	9003170022071	9009010023802	261
34049738	9003170022088	9009010023819	261
34050358	9003170031318		213
34050359	9003170031417		213
34050509	9003170031493		213
34050524	9003170031523		213
34050525	9003170031547		213
34051373	9003170022149	9009010024359	33
34051374	9003170022156	9009010024373	33
34051375	9003170022187	9009010024588	34
34053444	9003170031561	9009010026698	244
34053446	9003170031837	9009010026735	240
34053447	9003170031844	9009010026742	240
34053928	9003170050555	9009010041905	105
34053929	9003170053877	9009010042032	105
34053930	9003170062985	9009010042049	105
34053942	9003170065627	9009010042056	105
34054618	9003170023634	9009010025622	247
34054619	9003170023641	9009010025646	247
34054620	9003170031905	9009010026773	240
34054651	9003170031943	9009010026780	240
34054652	9003170031967	9009010026797	241
34054655	9003170032001	9009010026865	241
34054658	9003170032032	9009010026872	241
34054660	9003170023658	9009010025677	247
34054737	9003170023665	9009010025684	247
34054738	9003170023689	9009010025714	247
34054739	9003170023696	9009010025745	247
34054751	9003170023702	9009010025769	247
34054753	9003170023719	9009010025776	247
34054754	9003170023733	9009010025806	247
34054758	9003170023757	9009010025837	247
34054759	9003170023771	9009010025851	247
34054760	9003170023788	9009010025875	247

Type No.	EAN product	EAN packaging	Page
34054783	9003170023795	9009010025882	247
34054784	9003170023801	9009010025899	247
34054785	9003170023818	9009010025905	247
34054786	9003170023832	9009010025936	247
34054787	9003170023849	9009010025950	247
34054788	9003170023917	9009010025967	247
34054789	9003170023931	9009010026025	247
34054801	9003170023955	9009010026094	247
34054805	9003170023962	9009010026100	247
34054809	9003170024013	9009010026124	247
34054812	9003170024020	9009010026131	247
34054813	9003170024037	9009010026148	247
34054814	9003170024044	9009010026162	247
34054817	9003170024075	9009010026230	247
34054820	9003170024082	9009010026247	247
34054831	9003170024150	9009010026278	247
34054832	9003170024167	9009010026285	247
34054834	9003170024174	9009010026308	248
34054836	9003170024204	9009010026315	248
34054837	9003170024228	9009010026322	248
34054839	9003170024242	9009010026384	248
34054840	9003170024273	9009010026391	248
34054852	9003170024297	9009010026414	248
34054854	9003170024303	9009010026421	248
34054855	9003170024334	9009010026438	248
34054856	9003170024358	9009010026445	248
34054857	9003170024372	9009010026452	248
34054858	9003170024389	9009010026469	248
34054860	9003170024433	9009010026506	248
34054861	9003170024495	9009010026544	248
34054862	9003170024501	9009010026605	248
34054863	9003170024549	9009010026681	248
34057966	9003170024723	9009010027329	177
34057967	9003170024747	9009010027350	177
34057968	9003170024778	9009010027367	177
34057969	9003170024792	9009010027381	177
34059901	9003170025201	9009010027688	23
34059902	9003170025072	9009010027657	29
34059903	9003170025225	9009010027695	26
34059904	9003170025287	9009010027701	26

Type No.	EAN product	EAN packaging	Page
34059905	9003170025577	9009010027718	26
34059906	9003170025447	9009010027725	27
34059907	9003170025522	9009010027763	27
34059908	9003170025478	9009010027732	27
34059909	9003170025485	9009010027749	27
34059910	9003170025492	9009010027756	27
34060373	9003170025584	9009010027770	71
34060374	9003170025591	9009010027794	71
34060375	9003170025621	9009010027824	71
34060376	9003170025645	9009010027831	71
34060377	9003170025676	9009010027848	71
34060382	9003170025683	9009010027855	23
34061912	9003170026314		269
34061913	9003170026321		269
34061919	9003170026383		269
34061934	9003170026390		269
34061938	9003170026413		269
34061939	9003170026420		269
34061951	9003170026437		269
34061953	9003170026444		269
34061954	9003170026451		269
34061960	9003170026468		269
34062015	9003170026505		269
34062021	9003170026543		269
34062022	9003170026604		269
34062023	9003170026680		269
34062024	9003170026697		270
34062025	9003170026734		270
34062026	9003170026741		270
34062027	9003170026772		270
34063266	9003170027779	9009010029026	284
34063267	9003170027793	9009010029033	284
34063292	9003170027823	9009010029071	284
34063294	9003170036030	9009010029194	284
34063296	9003170027847	9009010029224	284
34063298	9003170027854	9009010029231	284
34063299	9003170027861	9009010029248	284
34063300	9003170027885	9009010029255	285
34063301	9003170027922	9009010029279	285
34063303	9003170027939	9009010029293	285



Type No.	EAN product	EAN packaging	Page
34063388	9003170026796	9009010028340	170
34063389	9003170026864	9009010028357	170
34063390	9003170026871	9009010028388	170
34063391	9003170026888	9009010028395	170
34063393	9003170026895	9009010028432	170
34063394	9003170027045	9009010028449	170
34063396	9003170027052	9009010028456	170
34063397	9003170027076	9009010028463	170
34063398	9003170027106	9009010028524	170
34063399	9003170027113	9009010028531	170
34063400	9003170027137	9009010028548	170
34063401	9003170027175	9009010028586	171
34063402	9003170027182	9009010028609	171
34063403	9003170027212	9009010028647	171
34063404	9003170027229	9009010028654	171
34063406	9003170027236	9009010028661	171
34072695	9003170029704	9009010030329	223
34072696	9003170029742	9009010030343	223
34072700	9003170029759	9009010030350	223
34072701	9003170029766	9009010030367	223
34077301	9003170030519		294
34162979	9003170033473	9009010031906	201
34162980	9003170033480	9009010031944	201
34162981	9003170033497	9009010031968	201
34162982	9003170033503	9009010032002	201
34162983	9003170033527	9009010032033	201
34162985	9003170033534	9009010032040	201
34162987	9003170033541	9009010032057	201
34162988	9003170033558	9009010032132	201
34162989	9003170033572	9009010032156	201
34162990	9003170033602	9009010032217	201
34163011	9003170033619	9009010032262	201
34163012	9003170033633	9009010032279	201
34163013	9003170033640	9009010032286	202
34163014	9003170033701	9009010032323	202
34163015	9003170033725	9009010032347	202
34163020	9003170033749	9009010032378	202
34163021	9003170033763	9009010032422	202
34163022	9003170033855	9009010032446	202
34163024	9003170033862	9009010032460	202

Type No.	EAN product	EAN packaging	Page
34163025	9003170033947	9009010032477	202
34163026	9003170033985	9009010032507	202
34163888	9003170034081	9009010032514	202
34163889	9003170034111	9009010032521	202
34163890	9003170034128	9009010032569	202
34163902	9003170034159	9009010032576	202
34163903	9003170034180	9009010032613	202
34163905	9003170034227	9009010032637	202
34163906	9003170034272	9009010032705	202
34163908	9003170034326	9009010032712	202
34163910	9003170034333	9009010032774	202
34163911	9003170034340	9009010032781	202
34163912	9003170034395	9009010032835	202
34163913	9003170034418	9009010032880	202
34163914	9003170034425	9009010032941	202
34163915	9003170034449	9009010032958	202
34163917	9003170034470	9009010032996	202
34163955	9003170034906	9009010033443	203
34163957	9003170034920	9009010033450	203
34163958	9003170034975	9009010033467	203
34163959	9003170034982	9009010033474	203
34163992	9003170034487	9009010033009	204
34163993	9003170034500	9009010033054	204
34163994	9003170034517	9009010033061	204
34163995	9003170034524	9009010033078	204
34163997	9003170034531	9009010033092	204
34163998	9003170034555	9009010033115	204
34163999	9003170034562	9009010033160	204
34164000	9003170034586	9009010033177	204
34164002	9003170034999	9009010033481	204
34164004	9003170035002	9009010033498	204
34164011	9003170034609	9009010033184	204
34164012	9003170034630	9009010033191	204
34164013	9003170034678	9009010033214	204
34164014	9003170034685	9009010033238	204
34164015	9003170034739	9009010033269	204
34164017	9003170034760	9009010033276	204
34164018	9003170034777	9009010033283	204
34164019	9003170034814	9009010033290	204
34164020	9003170034838	9009010033337	204

Type No.	EAN product	EAN packaging	Page
34164031	9003170034890	9009010033344	204
34165055	9003170035491	9009010033955	22
34165056	9003170035507	9009010033979	22
34165057	9003170035514	9009010033986	28
34165677	9003170039451	9009010035768	177
34165679	9003170039468	9009010035775	177
34165680	9003170039475	9009010035782	176
34165681	9003170039529	9009010035805	177
34166139	9003170039536	9009010035843	176
34166140	9003170039543	9009010035850	176
34166161	9003170039550	9009010035867	176
34166162	9003170039567	9009010035874	177
34166163	9003170039598	9009010035898	177
34166164	9003170039604	9009010035959	177
34166166	9003170039680	9009010035980	177
34166167	9003170039727	9009010036000	177
34166168	9003170039819	9009010036031	177
34166169	9003170039864	9009010036062	177
34166170	9003170039888	9009010036109	177
34166171	9003170039895	9009010036116	177
34166172	9003170039918	9009010036154	177
34166173	9003170039932	9009010036185	177
34166174	9003170040006	9009010036192	177
34166175	9003170040020	9009010036208	177
34166176	9003170040037	9009010036215	177
34166177	9003170040044	9009010036222	177
34166178	9003170040051	9009010036239	177
34166179	9003170040129	9009010036246	177
34166180	9003170040198	9009010036260	177
34166181	9003170040204	9009010036277	177
34166182	9003170040228	9009010036284	177
34166184	9003170040280	9009010036307	177
34166327	9003170036061	9009010034341	175
34166328	9003170036108	9009010034396	175
34166331	9003170036115	9009010034419	175
34166333	9003170036153	9009010034426	175
34166360	9003170036184	9009010034440	173
34166362	9003170036191	9009010034471	173
34166363	9003170036207	9009010034488	173
34166364	9003170036214	9009010034501	173

Type No.	EAN product	EAN packaging	Page
34166365	9003170036221	9009010034518	173
34166366	9003170036238	9009010034525	173
34166620	9003170036245	9009010034532	177
34166671	9003170036269	9009010034549	178
34166673	9003170036276	9009010034556	178
34166678	9003170036283	9009010034563	178
34166680	9003170036306	9009010034570	178
34166681	9003170036320	9009010034587	178
34166685	9003170036337	9009010034594	178
34166686	9003170036351	9009010034600	178
34166687	9003170036368	9009010034617	178
34166688	9003170036375	9009010034631	178
34166855	9003170036382	9009010034648	178
34166857	9003170036436	9009010034662	178
34166858	9003170036443	9009010034679	178
34166859	9003170036450	9009010034686	178
34166860	9003170036467	9009010034730	178
34166861	9003170036474	9009010034761	178
34166863	9003170036580	9009010034778	178
34166865	9003170036610	9009010034815	178
34166866	9003170036641	9009010034822	182
34166867	9003170036689	9009010034839	182
34166869	9003170036726	9009010034891	182
34166870	9003170036740	9009010034907	182
34166901	9003170036757	9009010034921	182
34166902	9003170036764	9009010034976	182
34166903	9003170036771	9009010034983	182
34166904	9003170036788	9009010034990	182
34166905	9003170036795	9009010035003	182
34166906	9003170036801	9009010035010	182
34166907	9003170036818	9009010035027	182
34166908	9003170036825	9009010035034	182
34168478	9003170038713	9009010035577	257
34168479	9003170038744	9009010035591	257
34168480	9003170038799	9009010035607	257
34168481	9003170038812	9009010035614	257
34168482	9003170038836	9009010035621	257
34168483	9003170038843	9009010035645	257
34179930	9003170050005	9009010042100	320
34179971	9003170212182	9009010042117	320









**TYROLIT  
ADDRESSES**

## TYROLIT ADDRESSES

 AT	<b>TYROLIT SCHLEIFMITTELWERKE SWAROVSKI K.G.</b> Swarovskistrasse 33 6130 Schwaz Austria	Tel: +43 5242 606-0 Fax: +43 5242 63398 atdeinfo@tyrolit.com www.tyrolit.com
 TT	<b>ALLIED INDUSTRIAL SUPPLIES COMPANY LTD.</b> # 2-12 Prince Charles Street San Fernando Trinidad And Tobago	Tel: +868-6526900 Fax: +868-652-6901 simonalexander@tsst.net.tt iscl@aiscl.net brendaalexander@aiscl.net
 US	<b>DIAMOND PRODUCTS LLC</b> 333, Prospect St. P.O. Box 1080 44035-6121 Elyria, Ohio United States	Tel: 1 440 323 46 16 Fax: 1 440 323 86 89 dp@diamondproducts.com www.diamondproducts.com
 GR	<b>T. I. RAPTOPOULOS &amp; SIA O.E.</b> Spirou Patsi 73 – Votanikos 118 55 – Athens Greece	Tel.: +30 210 3455473 Fax: +30 210 3412352 E-mail: contact@raptopoulos.gr Site: www.raptopoulos.gr
 ZA	<b>GRINDING TECHNIQUES</b> 28 Van Eck Street Chamdor Krugersdorp South Africa	Tel: +27 11 271 6400 Fax: +27 11 271 6464 info@grindtech.com www.grindtech.com
 PA	<b>INTERGLOBE TRADING</b> Bayside Center Coronado, Unit 17 Coronado Panama	Tel: +507-2401475 keith@interglobepanama.com www.interglobepanama.com
 BE	<b>N.V. TYROLIT BELGIUM S.A.</b> Verwelkomingsstraat 17 1070 Bruxelles Belgium	Tel: +32 2 556 08 00 Fax: +32 2 521 62 04 tyrolit-be@tyrolit.com www.tyrolit.com
 NL	<b>TYROLIT B.V.</b> Postbus 2198 1500 GD Zaandam Netherlands	Tel: 0900 653 14 34 Fax: +32 2 521 62 04 tyrolit-nl@tyrolit.com www.tyrolit.com
 SR	<b>SLIMBOUW</b> Rode Palmstraat 1 Paramaribo Suriname	Tel: +597-8575931 info@slimbouw.com www.slimbouw.com
 IL	<b>TENEGAL AGENCIES</b> 52A Hamasger Street IL-61573 Tel-Aviv Israel	Tel: +972-523105105 menahem@tenegal.com www.tenegal.com



	<b>TOOLTECHNIC SYSTEMS</b> P.O. Box 4401   Dandenong South VIC 3164 Australia	Tel: 1300 063 900 customercare@tooltechnic.com.au <a href="http://www.festool.com.au">http://www.festool.com.au</a>
	<b>TYROLIT A/S</b> Hestedostervej 21, 2. Sal, 2600, Glostrup Denmark	Tel: +45 43 55 74 00 Fax: +45 43 55 74 60 ordrer-dk@tyrolit.com <a href="http://www.tyrolit.com">www.tyrolit.com</a>
	<b>TYROLIT A/S</b> Akersbakken 12 0172 Oslo Norway	Tel: +47 416 290 00 ordre-no@tyrolit.com <a href="http://www.tyrolit.com">www.tyrolit.com</a>
	<b>TYROLIT A/B</b> c/o Tyrolit AB Enhagsslingan 4 /Box 533 183 25 Täby Sweden	Tel: +46 8 544 715 00 Fax: +46 8 544 715 01 order-se@tyrolit.com <a href="http://www.tyrolit.com">www.tyrolit.com</a>
	<b>TYROLIT ARGENTINA S.A.</b> Cnel. Manuel E. Arias 3751-17th floor C1430CRG Buenos Aires Argentina	Tel: +54 11 5543-2200 Fax: +54 11 5543-2232 ventas@tyrolit.com.ar <a href="http://www.tyrolit.com.ar">www.tyrolit.com.ar</a>
	<b>TYROLIT INDUSTRIAL ABRASIVES</b> 6165 Kennedy Road Mississauga, Ontario L5T 2S8 Canada	Phone: 905-565-9880 Fax: 905-565-9881 Toll Free: 1-877-TYROLIT (1-877-897-6548) Email: Tyrolit-ca@tyrolit.com <a href="http://www.tyrolit.com">www.tyrolit.com</a>
	<b>TYROLIT BALTICS OÜ</b> Läike tee 2/5 75312 Peetri küla, Rae vald, Harjumaa Estonia	Tel: +37 2 6066 841 Fax: +37 2 6066 842 info@tyrolit.ee <a href="http://www.tyrolit.com">www.tyrolit.com</a>
	<b>TYROLIT CEE K.S.</b> Tovární 363 294 71 Benátky nad Jizerou Czech Republic	Tel: +420 326 766 111 Fax: +420 326 766 105 cz.info@tyrolit.com <a href="http://www.tyrolit.com">www.tyrolit.com</a>
	<b>TYROLIT DO BRASIL LTDA.</b> Rod. D. Gabriel Paulino Bueno Couto, Km 81, 13315-970 Cabreúva Sao Paolo Brazil	Tel: +55 11 45298 70 0 Fax: +55 11 45297 25 7 brasil@tyrolit.com <a href="http://www.tyrolit.com.br">www.tyrolit.com.br</a>

 DE	<b>TYROLIT GMBH</b> Frauenstrasse 38 82216 Maisach Germany	Tel: +49 81 41 393-0 Fax: +49 81 41 393-100 atdeinfo@tyrolit.com www.tyrolit.de						
 CH	<b>NESTAG DIAMANT- &amp; SCHLEIFTECHNIK AG</b> Industriegebiet Matten 4458 Eptingen Switzerland	Tel. +41 62 285 10 10 Fax. +41 62 285 10 20 info@nestag.com www.tyrolit.com						
 HU	<b>TYROLIT KFT.</b> Fáy U.4. 1139 Budapest Hungary	Tel: +361 237 14 80 Fax: +361 237 14 89 tyrolith@t-online.hu www.tyrolit.com						
 PT	<b>TYROLIT LDA.</b> Zona Industrial do Alto da Cruz 4780 Santo Tirso Portugal	Tel: +351 252 859 390 Fax: +351 252 859 361 tyrolit-pt@tyrolit.com www.tyrolit.com.pt						
 IE	 UK	<b>TYROLIT LTD.</b> Eldon Close, Crick Northants NN6 7UD United Kingdom	Tel: +44 845 6868 200 Fax: +44 1788 823089 gb_enquiries@tyrolit.com www.tyrolit.co.uk					
 EG	 BD	 LB	 NG	 IR	 PK	 KE	<b>TYROLIT MIDDLE EAST FZE</b> P.O. Box 17842 Jebel Ali Free Zone Dubai	Tel: +971 4 813 9111 Fax: +971 4 813 9100 InfoTME@Tyrolit.com www.tyrolit.com
 BT	 NP	 ZA	 IQ	 QA	 LY	 IN		
 OM	 UG	 JO	 SA	 BH	 KW	 SY		
 AZ	 KZ	 LK	 KG	 AE				
 FI	<b>TYROLIT OY</b> c/o Tyrolit AB, box 533 183 25 Täby Sweden	Tel: +46 8 544 715 00 Fax: +46 8 544 715 01 tilaus-fi@tyrolit.com www.tyrolit.com						
 PL	<b>TYROLIT POLAND SP. Z O.O.</b> Białołęcka 233A 03-253 Warsaw Poland	Tel: +48 22 814 22 02 Fax: +48 22 814 22 03 biuro@tyrolit.com www.tyrolit.com						
 AD	 ES	 MA	<b>TYROLIT S.A.</b> Avda. 3a del Parc Logístic, nr. 26 Parc Logístic de la Zona Franca E-08040 Barcelona Spain	Tel: +34 93 223 98 20 Fax: +34 93 223 98 27 Tyrolit-es@tyrolit.com www.tyrolit.es				



**TYROLIT S.A.S.**  
Z.I. Rémy - 13 rue des Frères Rémy  
P.O. Box 60509  
57205 Sarreguemines Cedex  
France

Tel: +33 (0)3 87 27 66 70  
Fax: +33 (0)3 87 27 66 71  
tyrolit-fr@tyrolit.com  
www.tyrolit.com



**ABRA-METAL, INC.**  
724 Ave Julio Andino  
PR-00924 San Juan  
Puerto Rico

Tel: +787-2740505  
info@abrametal.com  
www.abrametal.com



**TYROLIT VINCENT S.P.A.**  
Via dell'Elettronica 6  
36016 Thiene (VI)  
Italy

IT: Tel: +39 0445 35 99 12  
Fax: +39 0445 370 84 3  
SM: Tel: +39 0445 35 99 11  
Fax: +39 0445 370 84 2  
Trade.it@tyrolit.com  
www.tyrolit.com



**TYROLIT THAI DIAMOND CO., LTD**  
1550 New Petchburi Road,  
Thanapoom Tower 20th Floor,  
10400 Bangkok  
Thailand

Tel: +6624021733  
Fax: +6622517863  
thtyroth@Tyrolit.com  
www.tyrolit.com



**UAB "TTS TOOLTECHNIC SYSTEMS"**  
Ašigalio g. 6  
LT-49142 Kaunas  
Lithuania

Tel: +370-61235295  
vma@tts-company.lt  
www.tts-company.lt



**N. APOSOLOU GENERAL TRADING LTD**  
Theonos 5  
1016 Nicosia  
Cyprus

Tel: +35799685101  
Mail: napostoloutrading@cablenet.com.cy

---

# CATALOGUE

## General information

The tools shown in this catalogue, the information regarding delivery, appearance, performance and dimensions shall comply with the according status at the time of printing. We develop our products continuously. We reserve the right to change without prior notice.

Reprinting as well as any kind of reproduction – even partially – is not permitted without the written permission of TYROLIT Schleifmittelwerke Swarovski K.G., 6130 Schwaz/Austria.

A detailed version of our terms and conditions can be found at

[www.tyrolit.com](http://www.tyrolit.com)





**TYROLIT SCHLEIFMITTELWERKE SWAROVSKI K.G.**

Swarovskistrasse 33 | 6130 Schwaz | Austria

Tel +43 5242 606-0 | Fax +43 5242 63398

Our **worldwide subsidiary companies** can be found  
on our website at [www.tyrolit.com](http://www.tyrolit.com)



Follow us on Facebook  
[facebook.com/TYROLIT](https://www.facebook.com/TYROLIT)